

WATER SYSTEM CONSTRUCTION STANDARDS

REVISED FEBRUARY 2019

Truckee Donner Public Utility District
11570 Donner Pass Road
Truckee, California 96161
(530) 587-3896

TABLE OF CONTENTS

STANDARD SPECIFICATIONS

<u>SECTION</u>	<u>DESCRIPTION</u>	<u>CURRENT REVISION DATE</u>
01000	General Provisions	JAN 2010
01070	Abbreviations Of Institutions	MAR 2001
01090	Reference Standards	FEB 2002
01300	Contractor Submittals	FEB 2002
01600	Products, Materials, Equipment, And Substitutions	MAR 2001
02200	Earthwork	JAN 2010
02225	Cutoff Walls	JAN 2010
02460	A.C. Pavement and Base	JAN 2010
02565	Ductile Iron Pipe	JAN 2019
02597	PVC Pressure Pipe	JAN 2010
02640	Large Water Service Connections	JAN 2015
02641	Water Service Connections	JAN 2019
02642	Hot Tap Connections	JAN 2010
02643	Water Pipeline Testing And Disinfection	JAN 2010
15202	Butterfly Valves	JAN 2010
15206	Gate Valves	JAN 2017
15231	Blowoff Assemblies	JAN 2010
15232	Air Valve Assemblies	JAN 2010
15233	Pressure Reducing Stations	JAN 2019
15235	Fire Hydrants	JAN 2019
NA	As-Built Drawing Requirements	JAN 2017

TABLE OF CONTENTS

STANDARD DETAILS

<u>DETAIL</u>	<u>DESCRIPTION</u>	<u>CURRENT REVISION DATE</u>
Trenching & Pipe Installation		
W-1.2	Construction Notes	2-7-2006
W-2.5	Joint Trench Detail	3-14-2007
W-3.4	Trench Detail For Pipe 4" & Larger	12-26-2007
W-4.5	Main Tap Detail	1-13-2015
W-5.1	Locator Wire Detail	3-13-2001
W-6.3	Thrust Block Bearing Areas	2-15-2004
W-7.3	Trench Detail For Parallel Pipe, 4" And Larger	12-26-2007
W-8.2	Mechanical Joint Restraint	2-24-2004
Services for Residential and Small Commercial Without Fire Sprinklers		
W-10.3	Trench Detail for Polyethylene Tubing, 2" and Smaller	12-26-2007
W-11.7	Single Pit Single Service Detail	1-9-2017
W-12.7	Single Pit Double Service Detail	1-9-2017
W-13.6	Double Pit Double Service Detail	1-9-2017
W-14.4	Traffic Rated Boxes for Meter Pit Installations	Jan 2010
W-15.7	Three Meter Service Detail	1-8-2019
W-16.6	Four Meter Service Detail	1-8-2019
W-18.6	Double Service Detail With Precast Concrete Boxes	1-8-2019
Valves & Fire Hydrants		
W-20.4	Gate Valve Detail	1-9-2017
W-21.2	Butterfly Detail	2-21-2006
W-22.6	Fire Hydrant Detail	2-28-2006
W-23.1	Fire Hydrant Cut Slope Pad	2-15-2005
W-24.1	Fire Hydrant Fill Slope Pad	2-15-2005
Air Valve & Blow-Off Assemblies		
W-30.6	1" Air Release Valve	12-26-2007
W-34.6	2" Blow Off Detail	1-9-2017
W-35.4	2" End Of Pipe Blow Off Detail	12-26-2007
Miscellaneous Details		
W-41.3	Typical Utility Locations At Property Corners	2-21-2006
W-43.2	Cutoff Wall Detail	12-20-2007
W-44.2	Required Vertical Separation Between Water and Non-Potable Pipelines	3-18-2004
W-45.8	Pressure Reducing Valve Station	2-10-2019
W-46.1	Barrier Post Detail	2-06-2004
W-48.1	Hydrostatic Pressure Testing Setup	Mar 2009

TABLE OF CONTENTS

<u>DETAIL</u>	<u>DESCRIPTION</u>	<u>CURRENT REVISION DATE</u>
Commercial Meter Details		
W-52.5	1" Disc Meter Detail	1-8-2019
W-53.5	1-1/2" Disc Meter Detail	1-8-2019
W-54.4	1-1/2" Turbine Meter Detail	1-8-2019
W-55.4	2" Disc Meter Detail	1-8-2019
W-56.4	2" Turbine Meter Detail	1-8-2019
W-57.5	3" Turbine Meter Detail	1-9-2017
W-58.5	4" Turbine Meter Detail	1-9-2017
W-60.3	3" Compound Meter Detail	1-8-2019
W-61.3	4" Compound Meter Detail	1-8-2019
W-62.2	6" Compound Meter Detail	1-9-2017
W-63.1	Meter Transmitter Unit Box Detail	Jan 2010
Services for Single-Family Residential with Fire Sprinklers		
W-70.3	Single Service Detail for SFR Connection with Fire Sprinklers	1-9-2017
W-71.4	Double Service Detail for SFR Connections with Fire Sprinklers	1-8-2019
W-72.2	Three Meter Service Detail for SFR Connections with Fire Sprinklers	1-8-2019
W-73.2	Four Meter Service Detail for SFR Connections with Fire Sprinklers	1-8-2019

SPECIFICATIONS

SECTION 01000 – DEVELOPMENT AGREEMENT GENERAL PROVISIONS

PART 1 -- GENERAL

1.1 DEFINITIONS AND TERMS

These definitions are supplemental to those defined elsewhere in the Development Agreement. Whenever in these Specifications the following terms are used, the intent and meaning shall be interpreted as follows:

- A. **CONTRACTOR** – The party that is performing actual physical construction and installation of water system facilities. The CONTRACTOR shall have a valid license issued by the State of California covering the type of work to be performed under the Development Agreement. The CONTRACTOR and the Developer may be the same party, or the CONTRACTOR may be a separate party retained by the Developer.
- B. **DEVELOPER** - The project developer or property owner who is responsible for the construction of the subject project and the required water system improvements. The Developer may utilize other parties or designated agents such as contractors, architects or engineers to perform the work described in the Development Agreement.
- C. **DEVELOPMENT AGREEMENT** - The written agreement between the Developer and the DISTRICT covering the WORK to be performed. The Approved Drawings, Specifications and Details are attached to the Development Agreement and made a part thereof as provided therein.
- B. **DISTRICT** – The Truckee Donner Public Utility District, along with its authorized agents and representatives, including but not limited to managers, inspectors, engineers and consultants
- D. **INSPECTOR** - An authorized representative of the DISTRICT assigned to make any or all inspections of the work performed and materials furnished by the CONTRACTOR.
- E. **LABORATORY** - A laboratory qualified to perform tests specified herein or other special laboratory designated by the DISTRICT or selected by the CONTRACTOR and approved by the DISTRICT.
- F. **OTHER AGENCIES** - Any legal entity of the State of California, or any utility district or company (county, electric company, telephone company, water district, sewer district, etc.)that has any interest or control in construction or construction inspection, or are performing other work within or adjacent to the project area.
- G. **SHOP DRAWINGS** - All drawings, diagrams, illustrations, brochures, schedules and other data which are prepared by the CONTRACTOR, a subcontractor, manufacturer, supplier or distributor, which illustrate how specific portions of the work shall be fabricated or installed.
- H. **SPECIFICATIONS** - A part of the Development Agreement consisting of written descriptions of a technical nature of materials, equipment construction systems, standards and workmanship; also referred to as the Technical Specifications.
- I. **STANDARD SPECIFICATIONS** - Whenever reference is made to the "Standard Specifications" such reference shall be made to those certain specifications entitled "State of California, Department of Transportation, Standard Specifications," latest edition, certain portions of which are made a part hereof by specific reference thereto.

Whenever the following underlined terms are used in the Standard Specifications, or in any documents or instruments governed by the Standard Specifications, they shall be defined as follows:

State: The DISTRICT.

Public Works Building: Office of the DISTRICT.

Department of Public Works: The DISTRICT.

Director of Public Works: The DISTRICT.

State Highway Engineer: The DISTRICT.

Engineer: The Engineer retained by the DISTRICT or authorized representative of the DISTRICT, acting either directly or through properly authorized agents, such agents acting within the scope of the particular duties delegated to them.

Laboratory: The established laboratory of the Materials and Research Department of the Department of Transportation of the State of California or laboratories authorized by the DISTRICT to test materials and work involved in the contract.

Reference is made to Section 1 of the Standard Specifications for other pertinent definitions.

- J. SUBCONTRACTOR - An individual, firm, or corporation having a direct contract with the CONTRACTOR or with any other subcontractor for the performance of a part of the work at the site.
- K. STANDARD PLANS - Whenever reference is made to the "Standard Plans" such reference shall be made to those certain plans entitled "State of California, Department of Transportation, Standard Plans," latest edition, certain portions of which are made a part hereof by specific reference thereto.
- L. SUPPLIER - Any person or organization who supplies materials or equipment for the work, including that fabricated to a special design, but who does not perform labor at the site.
- M. WORK - The entire completed construction or the various separately identifiable parts thereof required to be furnished under the Development Agreement. The WORK includes and is the result of performing or furnishing labor and furnishing and incorporating materials and equipment into the construction, and performing or furnishing services and furnishing documents, all as required by the Development Agreement.

1.2 INDEMNITY AGREEMENT

- A. The CONTRACTOR shall defend, indemnify and save harmless the DISTRICT and its agents and servants, and each of them, of and from any and all claims, demands, causes of action, damages, costs, expenses, losses, or liabilities, in law or in equity, or every kind and nature whatsoever, for, but not limited to, injury to or death of the CONTRACTOR, any subcontractor, or any employees of the DISTRICT, CONTRACTOR, or subcontractor, or any other person, and damages to or destruction of property of the DISTRICT or any other person, arising out of or in any manner directly or indirectly connected with the work to be performed under this Development Agreement, however caused, regardless of any negligence of the DISTRICT or its agents or servants, be it active or passive, except the

sole negligence or willful misconduct of the DISTRICT or its agents or servants. Said indemnification shall include the defense of any actions or other legal proceedings and reimbursement of attorneys' fees and other legal expenses incurred by the DISTRICT and shall include any and all penalties imposed upon the DISTRICT on account of the violation of any law or regulation by the CONTRACTOR.

1.3 INSURANCE

- A. Before commencement of any work under this Agreement, the CONTRACTOR shall take out and thereafter during the life of this Agreement maintain in full force and effect an insurance policy written upon a form and by a company which meets with the approval of the DISTRICT, insuring the DISTRICT, its officers, agents and employees against loss or liability which may arise during the WORK on the Project, or which may result from any of the WORK herein required to be done, including all costs of defending any claim arising as a result thereof. The minimum limits of such policy shall be in the amount of \$1,000,000 for the death of, or injury to, any person in any one accident, and \$2,000,000 for the death of, or injury to, more than one person in any one accident, and \$500,000 for property damage in any one accident. Said policy shall be written in favor of the CONTRACTOR and all subcontractors and also in favor of the DISTRICT, its officers, agents, and employees, and shall be maintained in full force and effect until the Project is unconditionally accepted by the DISTRICT. This insurance policy shall state by its terms that it shall not be canceled without thirty (30) days written notice thereto having been given to the DISTRICT.
- B. Before commencement of any WORK under this Agreement, the CONTRACTOR shall take out and thereafter during the life of this Agreement, maintain in full force and effect compensation insurance covering the CONTRACTOR's full liability for compensation to any person or persons who are or may be engaged in the execution of the WORK done under this Agreement, and to the dependents of such person or persons in compliance with all Worker's Compensation Insurance and Safety Laws of the State of California (California Labor Code Sections 3700 and following) and amendments thereto.
- C. Written proof of compliance with these requirements (A) and (B) shall be filed with and approved by the DISTRICT within fifteen (15) days of the date of Notice of Award of the contract and before commencement of the Project. The CONTRACTOR shall pay any and all deductibles required by these insurance policies.

1.4 INSPECTION AND TESTING

- A. When requested by the DISTRICT, the CONTRACTOR shall furnish a complete written statement of the origin, composition and manufacture of any or all materials that are to be used in the work.
- B. All materials may be inspected, sampled and tested by the DISTRICT. The CONTRACTOR shall give sufficient advance notice of placing in order to permit tests to be completed before the materials are incorporated in the work and he shall afford such facilities as the DISTRICT may require for collecting and making inspections. All samples shall be furnished by the CONTRACTOR without cost to the DISTRICT. The DISTRICT may waive sampling and testing if adequate information, properly certified, is available to indicate that materials comply with terms of the specifications.
- C. The CONTRACTOR shall furnish the DISTRICT with every reasonable facility for ascertaining whether or not the work as performed is in accordance with the requirements and intent of the Development Agreement. If the DISTRICT requests it, the CONTRACTOR at any time before acceptance of the work shall remove or uncover such portions of the

finished work as may be directed. After examination, the CONTRACTOR shall restore said portions of the work to the standards required by the Development Agreement. Inspection, supervision or observation by the DISTRICT shall not be considered as direct control of the individual workman and his work. The direct control shall be solely the responsibility of the CONTRACTOR's foremen and superintendent.

- D. The inspection of the work shall not relieve the CONTRACTOR of any of his obligation to construct the project in accordance with the Approved Drawings, and unsuitable materials may be rejected notwithstanding that such work and materials may have been previously overlooked and accepted or estimated for payment.
- E. On all questions concerning the acceptability of materials, classifications of materials, execution of the work, and the determination of costs, the decision of the DISTRICT shall be final and binding upon all parties.
- F. The CONTRACTOR shall at all times maintain proper facilities and provide safe access to all parts of the work, to the shops wherein the work is in preparation and to all warehouses and storage yards wherein equipment and materials are stored for purposes of inspection by the DISTRICT.
- G. Inspectors employed by the DISTRICT shall be authorized to inspect all work done and materials furnished. Such inspection may extend to all or any part of the work, and to the preparation, fabrication, or manufacture of the materials to be used. The Inspector is not authorized to alter or waive the provisions of the Development Agreement.
- H. An inspector is placed on the work to keep the DISTRICT informed as to the progress of the work and the manner in which it is being done; also to call the CONTRACTOR's attention to any non-conformance with the Development Agreement. The Inspector will not be authorized to approve or accept any portion of the work, to issue instructions contrary to the Development Agreement, or to act as foreman for the CONTRACTOR. The Inspector will have authority to reject defective material and to suspend any work that is being improperly performed, subject to the final decision of the DISTRICT.
- I. The Inspector will exercise such additional authority only as may from time to time be delegated to him by the DISTRICT.

1.5 ENGINEER OF RECORD

- A. The DISTRICT's Development Agreement guidelines require that the Approved Plans be stamped by an engineer licensed to practice within the State of California. The engineer who stamps the Approved Plans shall be considered the **Engineer of Record** for all construction the covered by the Development Agreement. The Developer shall maintain its contractual relationship with the **Engineer of Record** throughout the construction period and the **Engineer of Record** shall be available to the DISTRICT and the CONTRACTOR throughout the construction of the project to answer questions, clarify ambiguities and interpret the design as necessary to ensure proper construction.

1.6 COORDINATION AND INTERPRETATION OF THE DEVELOPMENT AGREEMENT

- A. The Approved Drawings and DISTRICT'S Construction Standards are essential parts of the Development Agreement, and a requirement occurring in one is as binding as though occurring in all. They are intended to be coordinated and to describe and provide for a complete work.

- B. Should it appear that the work to be done or any of the matters relative thereto are not sufficiently detailed or explained in the Development Agreement, the CONTRACTOR shall request of the DISTRICT and the **Engineer of Record** such further explanations as may be necessary and shall conform to such explanations.
- C. In the event of any doubt or question arising regarding the true meaning of any component of the Development Agreement, reference shall be made to the DISTRICT, whose decision thereon shall be final. In the event of any discrepancy, between any drawings and the details written thereon, the details shall be taken as correct.
- D. In the event of a conflict between any components of the Development Agreement, the CONTRACTOR shall request of the DISTRICT such further explanations as may be necessary and shall conform to such explanations.

1.7 SUSPENSION OF WORK

- A. The DISTRICT shall have the authority to suspend the work wholly or in part, for such period as it may deem necessary, due to unsuitable prosecution of the work, or for such time as he may deem necessary due to the failure on the part of the CONTRACTOR to carry out orders given, or to perform any provisions of the Development Agreement. The CONTRACTOR shall immediately comply with the written order of the DISTRICT to suspend the work wholly or in part. The suspended work shall be resumed when conditions are favorable and methods are corrected, as ordered or approved in writing by the DISTRICT.
- B. In case of suspension of work from any cause whatever, the CONTRACTOR shall be responsible for all materials and shall properly store them if necessary and shall provide suitable drainage and erect temporary structures where necessary.

1.8 DISTRICT'S WORKING HOURS

- A. The standard work day of the DISTRICT is the period from 7:30 AM to 4:00 PM. The standard work week begins on Monday and ends on Friday, excepting legal holidays. The DISTRICT's legal holidays are defined as the following: New Year's Day, President's Day, Memorial Day, Independence Day, Labor Day, Veterans Day, Thanksgiving Day, the Friday after Thanksgiving, Christmas Eve and Christmas Day.
- B. The CONTRACTOR shall schedule all inspection, testing and other activities requiring DISTRICT participation during the DISTRICT's standard working hours. If the CONTRACTOR desires to have inspection, testing or other activities requiring DISTRICT participation occur outside of those times, the CONTRACTOR shall reimburse the DISTRICT for the labor costs incurred by the DISTRICT.

1.9 LIMITATION OF DISTRICT'S RESPONSIBILITIES

- A. The DISTRICT will not supervise, direct, control or have authority over or be responsible for the CONTRACTOR's means, methods, techniques, sequences or procedures of construction, or the safety precautions and programs incident thereto, or for any failure of the CONTRACTOR to comply with Laws and Regulations applicable to the furnishing or performance of the WORK. The DISTRICT will not be responsible for CONTRACTOR's failure to perform or furnish the WORK in accordance with the Development Agreement.

- B. The DISTRICT will not be responsible for the acts or omissions of the CONTRACTOR or of any Subcontractor, any Supplier, or of any other person or organization performing or furnishing any portion of the WORK.

1.10 CONTRACTOR LICENSING

- A. All water system facilities shall be constructed by appropriately licensed contractors. Contractors shall have current and active licenses issued by the California Department of Consumer Affairs, Contractors License Board. The appropriate licenses for water system construction are typically “A – General Engineering Contractor”, or “C34 – Pipeline Contractor.

PART 2 – DESIGN GUIDANCE

2.1 GENERAL

- A. The information given in Part 2 is intended to assist Developers (and their agents) in preparing plans and specifications that comply with the DISTRICT’S Standards.

2.2 VALVES

- A. Isolation valves for 10-inch diameter and smaller piping shall be gate valves.
- B. Isolation valves for 12-inch diameter piping shall be butterfly valves except for hot tap valves, which shall be gate valves.
- C. Isolation valves for 14-inch diameter and larger piping shall be butterfly valves.
- D. Valve end connections shall be flanged, mechanical joint or other approved end connections as determined by the Developer and approved by the DISTRICT on the Approved Plans.

PART 3 -- EXECUTION (Not Used)

- END OF SECTION -

SECTION 01070 - ABBREVIATIONS OF INSTITUTIONS

PART 1 -- GENERAL

1.1 GENERAL

- A. Wherever in the Contract Documents references are made to the standards, specifications, or other published data of the various international, national, regional, or local organizations, such organizations may be referred to by their acronym or abbreviation only. As a guide to the reader, the following acronyms or abbreviations which may appear in the Contract Documents shall have the meanings indicated herein.

1.2 ABBREVIATIONS

AAMA	Architectural Aluminum Manufacturer's Association
AAR	Association of American Railroads
AASHTO	American Association of State Highway and Transportation Officials
ACI	American Concrete Institute
AFBMA	Anti-Friction Bearing Manufacturer's Association, Inc.
AGA	American Gas Association
AGMA	American Gear Manufacturers Association
AI	The Asphalt Institute
AIA	American Institute of Architects
AIEE	American Institute of Electrical Engineers
AISC	American Institute of Steel Construction
AISI	American Iron and Steel Institute
AITC	American Institute of Timber Construction
AMCA	Air Moving and Conditioning Association
ANSI	American National Standards Institute
APA	American Plywood Association
API	American Petroleum Institute
APWA	American Public Works Association
ASAE	American Society of Agricultural Engineers
ASCE	American Society of Civil Engineers
ASHRAE	American Society of Heating, Refrigerating, and Air Conditioning Engineers
ASLE	American Society of Lubricating Engineers
ASME	American Society of Mechanical Engineers
ASQC	American Society for Quality Control
ASSE	American Society of Sanitary Engineers
ASTM	American Society for Testing and Materials
AWPA	American Wood Preservers Association
AWPI	American Wood Preservers Institute
AWS	American Welding Society
AWWA	American Water Works Association
BHMA	Builders Hardware Manufacturer's Association
CBM	Certified Ballast Manufacturers
CEMA	Conveyors Equipment Manufacturer's Association
CGA	Compressed Gas Association
CLFMI	Chain Link Fence Manufacturer's Institute
CMA	Concrete Masonry Association
CRSI	Concrete Reinforcing Steel Institute
DCDMA	Diamond Core Drill Manufacturer's Association
EIA	Electronic Industries Association

ETL	Electrical Test Laboratories
EPA	Environmental Protection Agency
FM	Factory Mutual System
FPL	Forest Products Laboratory
HI	Hydraulic Institute
IAPMO	International Association of Plumbing and Mechanical Officials
ICBO	International Conference of Building Officials
ICEA	Insulated Power Cable Engineers Association
IEEE	Institute of Electrical and Electronics Engineers
IES	Illuminating Engineering Society
ISA	Instrument Society of America
ISO	Insurance Services Office
ISO	International Organization for Standardization
MBMA	Metal Building Manufacturer's Association
MPTA	Mechanical Power Transmission Association
MSS	Manufacturers Standardization Society
MTI	Marine Testing Institute
NAAMM	National Association of Architectural Metal Manufacturer's
NACE	National Association of Corrosion Engineers
NBS	National Bureau of Standards
NCCLS	National Committee for Clinical Laboratory Standards
NEC	National Electrical Code
NEMA	National Electrical Manufacturer's Association
NFPA	National Fire Protection Association
NFPA	National Forest Products Association
NLGI	National Lubricating Grease Institute
NSF	National Sanitation Foundation
NWMA	National Woodwork Manufacturers Association
OSHA	Occupational Safety and Health Administration
PCA	Portland Cement Association
PPI	Plastics Pipe Institute
RCRA	Resource Conservation and Recovery Act
RWMA	Resistance Welder Manufacturer's Association
SAE	Society of Automotive Engineers
SAMA	Scientific Apparatus Makers Association
SMA	Screen Manufacturers Association
SMACCNA	Sheet Metal and Air Conditioning Contractors National Association
SPI	Society of the Plastics Industry, Inc.
SSPC	Steel Structures Painting Council
SSPWC	Standard Specifications for Public Works Construction
UBC	Uniform Building Code
UL	Underwriters Laboratories, Inc.
WCLIB	West Coast Lumber Inspection Bureau
WCRSI	Western Concrete Reinforcing Steel Institute
WEF	Water Environment Federation
WIC	Woodwork Institute of California
WRI	Wire Reinforcement Institute, Inc.
WWPA	Western Wood Products Association

PART 2 -- PRODUCTS (Not Used)

PART 3 -- EXECUTION (Not Used)

- END OF SECTION -

SECTION 01090 - REFERENCE STANDARDS

PART 1 -- GENERAL

1.1 GENERAL

- A. **Titles of Sections and Paragraphs:** Captions accompanying specification sections and paragraphs are for convenience of reference only, and do not form a part of the Specifications.
- B. **Applicable Publications:** Whenever in these Specifications references are made to published specifications, codes, standards, or other requirements, it shall be understood that wherever no date is specified, only the latest specifications, standards, or requirements of the respective issuing agencies which have been published as of the date of execution of the Development Agreement, shall apply; except to the extent that said standards or requirements may be in conflict with applicable laws, ordinances, or governing codes. No requirements set forth herein or indicated in the Development Agreement shall be waived because of any provision of, or omission from, said standards or requirements.
- C. **Specialists and Assignments:** In certain instances, specification text requires (or implies) that specific WORK is to be assigned to specialists or expert entities, who must be engaged for the performance of that WORK. Such assignments shall be recognized as special requirements over which the CONTRACTOR has no choice or option. These requirements shall not be interpreted so as to conflict with the enforcement of building codes and similar regulations governing the WORK; also they are not intended to interfere with local union jurisdiction settlements and similar conventions. Such assignments are intended to establish which party or entity involved in a specific unit of work is recognized as "expert" for the indicated construction processes or operations. Nevertheless, the final responsibility for fulfillment of all conditions of the Development Agreement remains with the CONTRACTOR.

1.2 REFERENCE SPECIFICATIONS, CODES, AND STANDARDS

- A. Without limiting the generality of other requirements of the Specifications, all WORK specified herein shall conform to or exceed the requirements of applicable codes and the applicable requirements of the following documents.
- B. References herein to "Building Code" or "Uniform Building Code" shall mean Uniform Building Code of the International Conference of Building Officials (ICBO). Similarly, references to "Mechanical Code" or "Uniform Mechanical Code," "Plumbing Code" or "Uniform Plumbing Code," "Fire Code" or "Uniform Fire Code," shall mean Uniform Mechanical Code, Uniform Plumbing Code and Uniform Fire Code of the International Conference of the Building Officials (ICBO). "Electric Code" or "National Electric Code (NEC)" shall mean the National Electric Code of the National Fire Protection Association (NFPA). The latest edition of the codes as approved by the Municipal Code and used by the local agency as of the date of execution of the Development Agreement, as adopted by the agency having jurisdiction, shall apply to the Work herein, including all addenda, modifications, amendments, or other lawful changes thereto.
- C. In case of conflict between codes, reference standards, drawings and the Development Agreement, the most stringent requirements shall govern. All conflicts shall be brought to the attention of the DISTRICT for clarification and direction prior to ordering or providing any materials or furnishing labor.

- D. The CONTRACTOR shall construct the Work indicated herein in accordance with the requirements of the Development Agreement and the referenced portions of those referenced codes, standards, and specifications listed herein.
- E. **Applicable Standard Specifications:** References in the Development Agreement to the "Standard Specifications" shall mean the "Standard Specifications. State of California, Department of Transportation," latest edition at time of execution of the Development Agreement. Only those portions of the "Standard Specifications" specifically identified and referred to shall apply. Portions of the "Standard Specifications" not specifically referenced shall not be considered part of the Development Agreement.
- F. References herein to "OSHA Regulations for Construction" shall mean Title 29, Part 1926, Construction Safety and Health Regulations, Code of Federal Regulations (OSHA), including all changes and amendments thereto.
- G. References herein to "OSHA Standards" shall mean Title 29, Part 1910, Occupational Safety and Health Standards, Code of Federal Regulations (OSHA), including all changes and amendments thereto.

1.3 REGULATIONS RELATED TO HAZARDOUS MATERIALS

- A. The CONTRACTOR is responsible that all work included in the Development Agreement, regardless if shown or not, shall comply with all EPA, OSHA, RCRA, NFPA, and any other Federal, State, and Local Regulations governing the storage and conveyance of hazardous materials, including petroleum products.
- B. Where no specific regulations exist, all chemical, hazardous, and petroleum product piping and storage in underground locations must be installed with double containment piping and tanks, or in separate concrete trenches and vaults, or with an approved lining which cannot be penetrated by the chemicals, unless waived in writing by the DISTRICT.

PART 2 -- PRODUCTS (Not Used)

PART 3 -- EXECUTION (Not Used)

- END OF SECTION -

SECTION 01300 - CONTRACTOR SUBMITTALS

PART 1 -- GENERAL

1.1 GENERAL

- A. CONTRACTOR "Submittals" may be Shop Drawings, schedules, surveys, reports, samples, plans, lists, drawings, documents, findings, programs, manuals, data, or any other item or information required by the Development Agreement to be submitted or offered by the CONTRACTOR in accomplishing the Work.
- B. Wherever submittals are required hereunder, all such documents shall be furnished to the DISTRICT.
- C. The CONTRACTOR is responsible for the accuracy, completeness, and coordination of all Submittals. The CONTRACTOR shall not delegate this responsibility in whole or in part to any Subcontractor. Submittals may be prepared by the CONTRACTOR, Subcontractors or Suppliers, but the CONTRACTOR shall verify that each Submittal meets the requirements of the Development Agreement. The CONTRACTOR shall verify that there are no conflicts between Submittals and notify the DISTRICT in each case where a Submittal may affect the work of another contractor or the DISTRICT. The CONTRACTOR shall ensure coordination of Submittals of related crafts and Subcontractors.

1.2 PRECONSTRUCTION CONFERENCE SUBMITTALS

- A. Prior to the preconstruction conference, the CONTRACTOR shall submit the following items to the DISTRICT for review:
 - 1. A preliminary listing of Shop Drawings, Samples, and proposed Substitute ("Or-Equal") Submittals.
 - 2. The names and qualifications of Designated Safety Representative And Designated Competent Persons.
 - 4. Preliminary Progress Schedule.

1.3 SHOP DRAWINGS

- A. Wherever called for in the Development Agreement and these Specifications, or where required by the DISTRICT, the CONTRACTOR shall furnish for review, four copies of each Shop Drawing Submittal. Upon review, two copies shall be retained by the DISTRICT and two shall be returned to the CONTRACTOR. The term "Shop Drawings" as used herein shall be understood to include detail design calculations, shop drawings, fabrication, and installation drawings, erection drawings, lists, graphs, catalog sheets, data sheets, and similar items. Whenever the CONTRACTOR is required to submit design calculations as part of a Submittal, such calculations shall bear the signature and seal of a professional engineer registered in the appropriate branch in California unless otherwise directed.
- B. All Shop Drawing Submittals shall be accompanied by a Submittal transmittal form acceptable to the DISTRICT. The form shall indicate the Project and all specification references necessary to clearly denote which requirements are being satisfied by the Submittal. Any Submittal not accompanied by such a form, or where all applicable items on the form are not completed, will be returned for resubmittal.

- C. Normally, a single Shop Drawing Submittal shall be used for each technical specification section or item or class of material or equipment for which a Submittal is required. A single Submittal covering multiple sections will not be acceptable, unless the primary specification references other sections for components. Example: If a pump section references other sections for the motor, protective coating, anchor bolts, local control panel, and variable frequency drive, a single submittal would be accepted. However, a single Submittal covering vertical turbine pumps and horizontal split case pumps would not be acceptable.
- D. On the transmittal form, index the components of the Submittal and insert tabs in the Submittal to match the components. Relate the Submittal components to Specification paragraph and subparagraph, Drawing number, detail number, schedule title, or room number or building name, as applicable.
- E. Unless indicated otherwise, terminology and equipment names and numbers used in Submittals shall match the Development Agreement.
- F. Format:
 - 1. Minimum sheet size shall be 8.5 inches by 11 inches. Maximum sheet size shall be 24 inches by 36 inches. Every page in a Submittal shall be numbered in sequence. Each copy of a Submittal shall be collated and stapled or bound, as appropriate. The DISTRICT will not collate copies.
 - 2. Where product data from a manufacturer is submitted, clearly mark which model is proposed, with all pertinent data, capacities, dimensions, clearances, diagrams, controls, connections, anchorage, and supports. Sufficient level of detail shall be presented for assessment of compliance with the Development Agreement.
 - 3. Each Submittal shall be assigned a unique number. Submittals shall be numbered sequentially. The Submittal numbers shall be clearly noted on the transmittal. Original Submittals shall be assigned a numeric Submittal number. Resubmittals shall bear an alpha-numeric system which consists of the number assigned to the original Submittal for that item followed by a letter of the alphabet to represent that it is a subsequent Submittal of the original. For example, if Submittal 25 requires a resubmittal, the first resubmittal will bear the designation "25-A" and the second resubmittal will bear the designation "25-B" and so on.
- G. Disorganized Submittals which do not meet the requirements above will be returned without review.
- H. The DISTRICT will return prints of each Submittal to the CONTRACTOR with its comments noted thereon, within 7 calendar days following their receipt. For resubmittal of Submittals, the DISTRICT will be allowed the same review period as for the original Submittal. It is considered reasonable that the CONTRACTOR shall make a complete and acceptable Submittal to the DISTRICT by the second submission of a Submittal item.
- I. If two copies of a Submittal are returned to the CONTRACTOR marked "NO EXCEPTIONS TAKEN," formal revision and resubmission of said Submittal will not be required.
- J. If two copies of a Submittal are returned to the CONTRACTOR marked "MAKE CORRECTIONS NOTED," formal revision and resubmission of said Submittal will not be required.

- K. If a Submittal is returned to the CONTRACTOR marked "AMEND & RESUBMIT," revise said Submittal and resubmit the required number of copies. Resubmittal of portions of multi-page documents or multi-drawing documents will not be allowed. For example, if a Shop Drawing Submittal that consists of ten drawings contains only one drawing that needs to be amended and resubmitted, the Submittal as a whole is deemed as "AMEND & RESUBMIT", and all ten drawings of the Submittal would be required to be resubmitted.
- L. If a Submittal is returned to the CONTRACTOR marked "REJECTED," revise said Submittal and resubmit the required number of copies. Resubmittal of portions of multi-page documents or multi-drawing documents will not be allowed. For example, if a Shop Drawing Submittal that consists of ten drawings contains only one drawing that is rejected and needs to be resubmitted, the Submittal as a whole is deemed as "REJECTED", and all ten drawings of the Submittal would be required to be resubmitted.
- M. Any changes made on a resubmittal, other than those made or requested by the DISTRICT, shall be identified and flagged on the resubmittal.
- N. Fabrication of an item shall be commenced only after the DISTRICT has reviewed the pertinent submittals and has returned copies to the CONTRACTOR marked either "NO EXCEPTIONS TAKEN" or MAKE CORRECTIONS NOTED." Corrections indicated on Submittals shall be considered as changes necessary to meet the requirements of the Development Agreement.
- O. All Shop Drawing Submittals shall be carefully reviewed by an authorized representative of the CONTRACTOR, prior to submission. Each Submittal shall be dated, signed with the following: "I have verified that the equipment or material in this Submittal meets all the requirements specified or shown in the Development Agreement without exception." In the case of Shop Drawings, each sheet shall be so dated, signed, and certified. No consideration for review of any Submittals will be made for any items which have not been so certified. All non-certified Submittals will be returned without action taken, and any delays caused thereby shall be the total responsibility of the CONTRACTOR. Submittals which the CONTRACTOR wishes to have reviewed that cannot bear this certification because they include an exception or deviation to the Development Agreement shall be submitted in accordance with Section 01600 - Products, Materials, Equipment, and Substitutions.
- P. The DISTRICT's review of Shop Drawing Submittals shall not relieve the CONTRACTOR of the entire responsibility for the correctness of details and dimensions and for compliance with the Development Agreement. The CONTRACTOR shall assume all responsibility and risk for any misfits due to any errors in Submittals. The CONTRACTOR shall be responsible for the dimensions and the design of adequate connections and details.
- Q. If the CONTRACTOR submits an incomplete Submittal, the Submittal may be returned without review. A complete Submittal shall contain sufficient data to demonstrate that the items contained therein comply with the Development Agreement, meet the minimum requirements for Submittals as described in the Development Agreement, and include all corrections as required from previous Submittals.

1.4 SAMPLES

- P. Whenever in the Specifications samples are required, submit not less than three samples of each item or material for acceptance, at no additional cost to the DISTRICT.

- Q. Samples, as required herein, shall be submitted for acceptance a minimum of 21 days prior to ordering such material for delivery to the jobsite, and shall be submitted in an orderly sequence so that dependent materials or equipment can be assembled and reviewed without causing delays in the WORK.
- R. All samples shall be individually and indelibly labeled or tagged, indicating thereon all specified physical characteristics and Manufacturer's name for identification. Upon receiving acceptance of the DISTRICT, one set of the samples will be stamped and dated and returned to the CONTRACTOR, and two sets of samples will be retained, and one set of samples shall remain at the job site until completion of the Work.

1.5 SURVEY DATA

- A. The CONTRACTOR shall make available for examination throughout the construction period all field books, notes, and other data developed by CONTRACTOR in performing the surveys required by the WORK and submit all such data to DISTRICT with documentation required for final acceptance of the WORK.

1.6 RECORD DRAWINGS

- A. The CONTRACTOR shall prepare as-built drawings as required in the DISTRICT'S "As-Built Drawing Policy."

PART 2 -- PRODUCTS (Not Used)

PART 3 -- EXECUTION (Not Used)

- END OF SECTION -



Submittal Certification

Contractor:	Contractor's License No.:
Project Name:	
Submittal Number:	Date:

I hereby certify that I have verified that the equipment or material in this Submittal meets all the requirements specified or shown in the Contract Documents without exception.

Name: _____

Signature: _____

Date: _____

SECTION 01600 - PRODUCTS, MATERIALS, EQUIPMENT AND SUBSTITUTIONS

PART 1 -- GENERAL

1.1 DEFINITIONS

- A. The word "Products," as used herein, is defined to include purchased items for incorporation into the WORK, regardless of whether specifically purchased for the project or taken from CONTRACTOR's stock of previously purchased products.
- B. The word "Materials," is defined as products which must be substantially cut, shaped, worked, mixed, finished, refined, or otherwise fabricated, processed, installed, or applied to form units of work.
- C. The word "Equipment" is defined as products with operational parts, regardless of whether motorized or manually operated, and particularly including products with service connections (wiring, piping, and other like items).
- D. Definitions given in this specification section are not intended to negate the meaning of other terms used in the Development Agreement, including "specialties," "systems," "structure," "finishes," "accessories," "furnishings," special construction," and similar terms, which are self-explanatory and have recognized meanings in the construction industry.
- E. Neither "Products" nor "Materials" nor "Equipment" includes machinery and equipment used for preparation, fabrication, conveying and erection of the WORK.

1.2 QUALITY ASSURANCE

- A. **Source Limitations:** To the greatest extent possible for each unit of work, the CONTRACTOR shall provide products, materials, and equipment of a singular generic kind from a single source.
- B. **Compatibility of Options:** Where more than one choice is available as options for CONTRACTOR's selection of a product, material, or equipment, select an option which is compatible with other products, materials, or equipment. Compatibility is a basic general requirement of product, material and equipment selections.

1.3 PRODUCT DELIVERY AND STORAGE

- A. The CONTRACTOR shall deliver and store the WORK in accordance with manufacturer's written recommendations and by methods and means that will prevent damage, deterioration, and loss including theft. Delivery schedules shall be controlled to minimize long-term storage of products at Site and overcrowding of construction spaces. In particular, ensure coordination to ensure minimum holding or storage times for flammable, hazardous, easily damaged, or sensitive materials to deterioration, theft, and other sources of loss.

1.4 TRANSPORTATION AND HANDLING

- A. Products shall be transported by methods to avoid damage and shall be delivered in undamaged condition in manufacturer's unopened containers and packaging.

- B. The CONTRACTOR shall furnish equipment and personnel to handle products, materials, and equipment, including those provided by DISTRICT, by methods to prevent soiling and damage.
- C. The CONTRACTOR shall provide any additional protection necessary during handling to prevent marring and otherwise damaging products, packaging, and surrounding surfaces.

1.5 STORAGE AND PROTECTION

- A. Products shall be stored in accordance with manufacturer's written instructions and with seals and labels intact and legible. Sensitive products shall be stored in weather-tight climate controlled enclosures and temperature and humidity ranges shall be maintained within tolerances required by manufacturer's recommendations.
- B. For exterior storage of fabricated products, products shall be placed on sloped supports above ground. Products subject to deterioration shall be covered with impervious sheet covering and ventilation shall be provided to avoid condensation.
- C. Loose granular materials shall be stored on solid flat surfaces in a well-drained area and shall be prevented from mixing with foreign matter.
- D. Storage shall be arranged to provide access for inspection. Periodically inspect to assure products are undamaged and are maintained under required conditions.
- E. Storage shall be arranged in a manner to provide access for maintenance of stored items and for inspection.

1.6 MAINTENANCE OF STORAGE

- A. Stored products shall be periodically inspected on a scheduled basis. Maintain a log of inspections and make the log available on request.
- B. The CONTRACTOR shall comply with manufacturer's product storage requirements and recommendations.
- C. The CONTRACTOR shall maintain manufacturer-required environmental conditions continually.
- D. The CONTRACTOR shall ensure that surfaces of products exposed to the elements are not adversely affected and that weathering of finishes does not occur.
- E. For mechanical and electrical equipment, the CONTRACTOR shall provide a copy of the manufacturer's service instructions with each item and the exterior of the package shall contain notice that instructions are included.

1.7 PROPOSED SUBSTITUTIONS OR "OR-EQUAL" ITEM

- A. Whenever materials or equipment are indicated in the Development Agreement by using the name of a proprietary item or the name of a particular Supplier, the naming of the item is intended to establish the type, function, and quality required. If the name is followed by the words "or equal" indicating that a substitution is permitted, materials or equipment of other suppliers may be accepted if sufficient information is submitted to allow the DISTRICT to determine that the material or equipment proposed is equivalent or equal to that named, subject to the following requirements:

1. The burden of proof as to the type, function, and quality of any such substitution product, material or equipment shall be upon the CONTRACTOR.
 2. The DISTRICT will be the sole judge as to the type, function, and quality of any such substitution and the DISTRICT's decision shall be final.
 3. The DISTRICT may require the CONTRACTOR to furnish additional data about the proposed substitution.
 4. The DISTRICT may require the CONTRACTOR to furnish a special performance guarantee or other surety with respect to any substitution.
 5. Acceptance by the DISTRICT of a substitution item shall not relieve the CONTRACTOR of the responsibility for full compliance with the Development Agreement and for adequacy of the substitution.
 6. The CONTRACTOR shall be responsible for resultant changes including design and construction changes resulting from the changes which the accepted substitution requires in the CONTRACTOR's WORK, the WORK of its Subcontractors and of other contractors.
- B. If the name of a proprietary item or the name of a particular Supplier is not followed by the words "or equal", substitutions are not allowed and the specified product shall be furnished by the CONTRACTOR with the following exceptions:
1. In the event that a named Supplier is no longer doing business under the name indicated, the specified product from the legal successors to the named Supplier shall be furnished.
 2. In the event that a named product is no longer available from the named Supplier due to acquisition or sale of the given product line, but the product is available from another Supplier, the CONTRACTOR shall provide the named product. In such cases, the CONTRACTOR shall submit a Substitution Request Form and shall include certification from the Supplier that product being supplied is materially and functionally identical to the product named in the Development Agreement.
 3. In the event that a named product is no longer available from the named Supplier or any other Supplier, the CONTRACTOR shall notify the DISTRICT in writing and the DISTRICT shall identify suitable substitute products. The CONTRACTOR shall provide one of the suitable substitute products.
- C. The procedure for review of proposed substitutions by the DISTRICT will include the following:
1. If the CONTRACTOR wishes to provide a substitution item, make written application to the DISTRICT on the "Substitution Request Form."
 2. The CONTRACTOR shall certify that the proposed substitution will perform adequately the functions and achieve the results called for by the general design, and be similar and of equal substance to that indicated, and be suited to the same use as that indicated.

3. The DISTRICT will evaluate each proposed substitution within a reasonable period of time.
 4. As applicable, no shop drawing submittals shall be made for a substitution item nor shall any substitution item be ordered, installed, or utilized without the DISTRICT'S prior written acceptance of the CONTRACTOR'S "Substitution Request Form."
 5. Wherever the submission of a proposed substitution material or equipment has been judged to be unacceptable by the DISTRICT, the CONTRACTOR shall provide the material or equipment indicated in the Development Agreement.
- D. The CONTRACTOR's application using the "Substitution Request Forms" shall contain the following statements and information that will be considered by the DISTRICT in evaluating the proposed substitution:
1. Whether or not acceptance of the substitution for use in the WORK will require a change in any of the Development Agreement to adapt the design to the proposed substitution.
 2. Whether or not incorporation or use of the substitution in connection with the WORK is subject to payment of any license fee or royalty.
 3. Information in the substitution request shall be organized in the format required for submittals as described in Section 01300 - Contractor Submittals. Non-compliant substitution requests will not be reviewed.
 4. All variations of the proposed substitution from the items originally indicated shall be identified.
 5. Available maintenance, repair, and replacement service shall be indicated. The manufacturer shall have a local service agency that maintains properly trained personnel and adequate spare parts and is able to respond and complete repairs within 24 hours.
- E. The CONTRACTOR shall be responsible for and pay all costs in connection with proposed substitutions and of inspections and testing of equipment or materials submitted for review prior to the CONTRACTOR's purchase thereof for incorporation in the WORK, whether or not the DISTRICT accepts the proposed substitution or proposed equipment or material. The CONTRACTOR shall reimburse the DISTRICT for the charges of the DISTRICT, and other authorized representatives for evaluating each proposed substitution and costs for any additional inspection caused by the substitution.

PART 2 -- PRODUCTS (Not Used)

PART 3 -- INSTALLATION (Not Used)

- END OF SECTION -

SECTION 02200 – EARTHWORK

PART 1 -- GENERAL

1.1 THE REQUIREMENT

- A. The CONTRACTOR shall perform all earthwork indicated and required for construction of the Work in accordance with the Development Agreement.
- B. The CONTRACTOR's attention is directed to the provisions for "Shoring and Bracing Drawings" in Section 6705 of the California Labor Code. The CONTRACTOR, prior to beginning any trench or structure excavation requiring shoring, shall develop a detailed plan showing design of all shoring, bracing, sloping of the sides of excavation, or other provisions for worker protection against the hazard of caving ground during the excavation of such trenches or structure excavation. If such plan varies from the shoring system standards established in the Construction Safety Orders of the State of California, such alternative systems plans shall be prepared by a civil or structural engineer licensed in the State of California.

1.2 REFERENCE SPECIFICATIONS, CODES, AND STANDARDS

ASTM C150	Portland Cement
ASTM C618	Coal Fly Ash and Raw or Calcined Natural Pozzolan for Use as a Mineral Admixture in Concrete
ASTM D422	Standard Test Method for Particle-Size Analysis of Soils
ASTM D1556	Standard Test Method for Density and Unit Weight of Soil in Place by the Sand-Cone Method
ASTM D1557	Test Method for Laboratory Compaction Characteristics of Soils Using Modified Effort (56,000 ft - lbf/ft ³) (2,700 kN-m/m ³)
ASTM D1633	Standard Test Method for Compressive Strength of Molded Soil-Cement Cylinders
ASTM D2419	Standard Test Method for Sand Equivalent Value of Soils and Fine Aggregate
ASTM D2487	Standard Classification of Soils for Engineering Purposes (Unified Soil Classification System)
ASTM D 2901	Standard Test Method for Cement Content of Freshly Mixed Soil Cement
ASTM D2922	Standard Test Methods for Density of Soil and Soil-Aggregate in Place by Nuclear Methods (Shallow Depth)
ASTM D4253	Standard Test Method for Maximum Index Density and Unit Weight of Soils Using a Vibratory Table

ASTM D4254 Standard Test Method for Minimum Index Density and Unit Weight of Soils and Calculation of Relative Density

California Test 643 Method for Estimating the Service Life of Steel Culverts

PART 2 -- PRODUCTS

2.1 SUITABLE FILL AND BACKFILL MATERIAL REQUIREMENTS

- A. **General:** Fill, backfill, and embankment materials shall be suitable selected or processed clean, fine earth, rock, or sand, free from grass, roots, brush, or other vegetation.
- B. **Suitable Materials:** Materials defined below are suitable materials and may be used in fills, backfilling, and embankment construction subject to the indicated limitations.
- C. The following types of suitable materials are defined:
1. Type A (three-inch minus granular backfill): Crushed rock or gravel, and sand with the gradation requirements below. Volcanic cinders meeting these requirements may be used.

<u>Sieve Size</u>	<u>Percentage Passing</u>
3-inch	100
No. 4	35 - 100
No. 40	20 - 100
No. 200	0 - 25

2. Type B (three-quarter inch minus granular backfill): Crushed rock or gravel, and sand with the gradation requirements below. The material shall have a minimum sand equivalent value of 20. Volcanic cinders meeting these requirements may be used.

<u>Sieve Size</u>	<u>Percentage Passing</u>
3/4-inch	100
No. 4	35 -100
No. 200	0 - 15

3. Type C (sand backfill): Clean well graded sand meeting the gradation requirements below. Material shall have a sand equivalent value not less than 30.

<u>Sieve Size</u>	<u>Percentage Passing</u>
3/8-inch	100
No. 4	50 -90
No. 200	0 - 20

4. Type D (six-inch minus granular backfill): Clean well graded stone, gravel and sand meeting the gradation requirements below.

<u>Sieve Size</u>	<u>Percentage Passing</u>
6-inch	100
3-inch	80 - 100
No. 4	35 - 100

5. Type E (pea gravel backfill): Crushed rock or gravel with 100 percent passing a 1/2-inch sieve and not more than 10 percent passing a Number 4 sieve.
6. Type F (coarse drain rock): Crushed rock or gravel meeting the following gradation requirements:

<u>Sieve Size</u>	<u>Percentage Passing</u>
2-inch	100
1-1/2-inch	90 - 100
1-inch	20 - 55
3/4-inch	0 - 15

7. Type G (aggregate base): Aggregate base shall conform to the requirements given in Section 02460 – A.C. Pavement & Base.
8. Type H (graded drain rock): Drain rock shall be crushed rock, gravel or sand, durable and free from slaking or decomposition under the action of alternate wetting or drying. The drain rock shall have a sand equivalent value not less than 75. The material shall be uniformly graded and shall meet the following gradation requirements:

<u>Sieve Size</u>	<u>Percentage Passing</u>
3/4-inch	100
1/2-inch	95 – 100
3/8-inch	70 – 100
No. 4	0 - 55
No. 8	0 - 10
No. 200	0 - 3

9. Type I: Not Used
10. Type J (Soil Cement): Material which consists of any mixture of Types B, C, G, and H materials which has been cement-treated so that the cement content of the material is not less than 5 percent by weight when tested in accordance with ASTM D2901. The ultimate compressive strength at 28 days shall be not less than 400 psi when tested in accordance with ASTM D 1633.
11. Type K (topsoil): Stockpiled topsoil material which has been obtained at the site by removing soil to a depth not exceeding 2 feet. Removal of the topsoil shall be done after the area has been stripped of vegetation and debris.
12. Type L (slurry cement backfill): Slurry cement backfill shall conform to the requirements of Section 19-3.062 of the Standard Specifications.
13. Type M (aggregate subbase): Not Used

2.2 UNSUITABLE MATERIAL

A. Unsuitable materials include the materials listed below.

1. Soils which, when classified under ASTM D 2487, fall in the classifications of PT, OH, CH, MH, or OL.

2. Soils which cannot be compacted sufficiently to achieve the density specified for the intended use.
3. Materials that contain hazardous or designated waste materials including petroleum hydrocarbons, pesticides, heavy metals, and any material which may be classified as hazardous or toxic according to applicable regulations.
4. Soils that contain greater concentrations of chloride or sulfate ions, or have a soil resistivity or pH less than the existing on-site soils.
5. Topsoil, except as allowed below.

2.3 USE OF MATERIAL TYPES

- A. The CONTRACTOR shall use the types of materials as designated herein for all required fill and backfill construction hereunder.
- B. Where these Specifications conflict with the requirements of any local agency having jurisdiction or with the requirements of a pipe material manufacturer, the DISTRICT shall be immediately notified. In case of conflict between types of pipe embedment backfills, the CONTRACTOR shall use the backfill material that provides a greater degree of structural support to the pipe, as determined by the DISTRICT. In case of conflict between types of trench or final backfill types, the CONTRACTOR shall use the backfill material that provides the greater in-place density after compaction.
- C. Fill and backfill types shall be used in accordance with the following provisions:
 1. Pipe zone backfill, as defined in Article 3.6 of this Section, shall be Type B material. In those locations where water pipe is installed in a joint trench with other piping and conduits, backfill shall be Type C material.
 2. Trench zone backfill, as defined in Article 3.6 of this Section, shall be as follows:
 - a. Trench zone backfill in areas to be paved shall be Type A or Type L material.
 - b. Trench zone backfill in areas not to be paved shall be Type D or Type L material.
 3. Final backfill material for pipelines under paved areas, as defined in Article 3.6 of this Section, shall be Type G backfill material. Final backfill under areas not paved shall be Type D material.
 4. Aggregate base materials under pavements shall be Type G material constructed to the thicknesses indicated.
 5. Backfill around vault structures shall be as indicated in the Approved Drawings.
 6. Backfill used to replace pipeline trench over-excavation shall be the same material as used for the pipe zone backfill if the trench conditions are not wet. If trench conditions are wet, a layer of Type F material with a layer of filter fabric to prevent migration of fines shall be used. Filter fabric shall comply with the requirements given for Underdrains in Section 88-1.03 of the Standard Specifications.

2.4 MATERIALS TESTING

- A. The CONTRACTOR shall be responsible for demonstrating compliance with these Specifications. If requested by the DISTRICT, the CONTRACTOR shall submit samples for testing to a certified testing laboratory. Such testing shall be performed at the CONTRACTOR'S expense.
- B. Particle size analysis of soils and aggregates shall be performed in accordance with ASTM D422.
- C. Determination of sand equivalent value shall be performed in accordance with ASTM D2419.
- D. The testing for chloride, sulfate, resistivity, and pH shall be done in accordance with California Test Method 643 of the California Department of Transportation.
- E. **Unified Soil Classification System:** References in this Section to soil classification types and standards shall have the meanings and definitions indicated in ASTM D2487. The CONTRACTOR shall be bound by all applicable provisions of said ASTM D2487 in the interpretation of soil classifications.

PART 3 -- INSTALLATION

3.1 EXCAVATION - GENERAL

- A. **General:** Except when specifically provided to the contrary, excavation shall include the removal of all materials (including rock) of whatever nature encountered, including all obstructions of any nature that would interfere with the proper execution and completion of the Work. The removal of said materials shall conform to the lines and grades indicated in the Approved Drawings. The CONTRACTOR shall furnish, place, and maintain all supports and shoring that may be required for the sides of the excavations. Excavations shall be sloped or otherwise supported in a safe manner in accordance with applicable State safety requirements and the requirements of OSHA Safety and Health Standards for Construction (29CFR1926).
- B. **Removal and Exclusion of Water:** The CONTRACTOR shall remove and exclude water, including stormwater, groundwater, irrigation water, water from leaking pipes, and wastewater, from all excavations. Dewatering wells, well points, sump pumps, or other means shall be used to remove water and continuously maintain groundwater at a level at least two feet below the bottom of excavations. Water shall be removed and excluded until backfilling is complete and all field soils testing has been completed.
- C. The CONTRACTOR is hereby notified that investigations of subsurface soil conditions have not been conducted by the DISTRICT.
- D. If a moveable trench shield is used during excavation operations, the trench width shall be wider than the shield so that the shield is free to be lifted and then moved horizontally without binding against the trench sidewalls. If the trench walls cave in or slough, the trench shall be excavated as an open excavation with sloped sidewalls, or trench shoring shall be used.

3.2 PIPELINE AND UTILITY TRENCH EXCAVATION

A. **Trench Excavation:**

1. The CONTRACTOR shall excavate and expose buried points of connection to existing utilities where indicated on the Approved Drawings. Excavation shall be performed prior to preparation of any required Shop Drawings for connections and before fabrication of any pipe.
2. Excavations for pipelines and utilities shall be open-cut trenches with widths as indicated in the Approved Drawings. Trench width shall be adequate to allow the pipe to be aligned in the center of trench, including pipes installed on curves. In no case shall the distance from the edge of the trench to the edge of the pipe be less than 12-inches.
3. Any damage to utilities from excavation activities shall be repaired by the CONTRACTOR at no cost to the DISTRICT.

B. **Trench Bottom:** The bottom of the trench shall be excavated uniformly to the grade of the bottom of the pipe bedding. Excavations for pipe bells, couplings and flanges shall be made as required. The use of mounds of material to support the pipe shall not be permitted.

C. **Trench Over-Excavation:** Where trenches are indicated to be over-excavated, excavation shall be to the depth indicated, and backfill shall be installed to the grade of the bottom of the pipe bedding.

D. **Over-Excavation:** When ordered by the DISTRICT, whether indicated on the Approved Drawings or not, trenches shall be over-excavated beyond the depth and/or width shown. Such over-excavation shall be to the dimensions ordered. The trench shall then be backfilled to the grade of the bottom of the pipe bedding.

E. Where pipelines are to be installed in embankments or fills, the fill shall be constructed to a level at least one foot above the top of the pipe before the trench is excavated.

3.3 OVER-EXCAVATION NOT INDICATED

A. Any over-excavation carried below the grade ordered or indicated, shall be backfilled to the required grade with the indicated material and compaction. Such work shall be performed by the CONTRACTOR at no additional cost to the DISTRICT.

3.4 PLACING AND SPREADING OF BACKFILL MATERIALS

A. Except for drain rock materials being placed in over-excavated areas or trenches, backfill shall be placed after all water is removed from the excavation.

B. Immediately prior to placement of backfill materials, the bottoms and sidewalls of trenches and structure excavations shall have all loose sloughing, or caving soil and rock materials removed. Trench sidewalls shall consist of excavated surfaces that are in a relatively undisturbed condition before placement of backfill materials.

C. Backfill shall not be dropped directly upon any structure or pipe. Backfill materials shall be placed and spread evenly in layers not to exceed 8-inches in thickness

- D. Pipe zone backfill materials shall be manually spread around the pipe so that when compacted the pipe zone backfill will provide uniform bearing and side support. Backfill material shall be placed into the void space in the haunches of the pipe by the use of hand tools such shovels and spades. The CONTRACTOR shall not rely upon the compactive effort of machinery to move the material into the void space.
- E. Backfill material shall have a moisture content of optimum plus or minus 4 percent at the time of compaction. Where the backfill material moisture content is below the optimum moisture content, water shall be added before or during spreading until the proper moisture content is achieved. Where the backfill material moisture content is too high to permit the specified degree of compaction the material shall be dried until the moisture content is satisfactory.

3.5 COMPACTION OF FILL, BACKFILL, AND EMBANKMENT MATERIALS

- A. Compaction by flooding, ponding, or jetting shall not be allowed.
- B. **Compaction Requirements:** The following compaction test requirements shall be in accordance with ASTM D1557 for Type A, B, C, G, H, I, K and M materials and in accordance with ASTM D4253 and D4254 for Type D, E, F, and J materials.

<u>Location or Use of Fill</u>	<u>Percentage of Maximum Density</u>
Pipe zone backfill	90
Trench zone backfill, beneath paved areas or structures	95
Trench zone backfill, not beneath paved areas or structures	90
Final backfill, beneath paved areas or structures	95
Final backfill, not beneath paved areas or structures	90
Embankments and fills beneath paved areas or structures	95
Embankments and fills, not beneath paved areas or structures	90
Topsoil (Type K material)	80
Aggregate base (Type G material)	95

3.6 PIPE AND UTILITY TRENCH BACKFILL

- A. **Pipe Zone Backfill:** The pipe zone is defined as that portion of the vertical trench cross-section lying between a plane 6-inches below the bottom surface of the pipe and a plane at a point 12-inches above the top surface of the pipe. The pipe zone shall be backfilled with the indicated backfill material. The CONTRACTOR shall exercise care to prevent damage to the pipeline coating, cathodic bonds, and the pipe itself during the installation and backfill operations.
- B. **Trench Zone Backfill:** After the pipe zone backfill has been placed, backfilling of the trench zone may proceed. The trench zone is defined as that portion of the vertical trench cross-section lying as indicated between a plane 12-inches above the top surface of the

pipe and a plane at a point 18 inches below the finished surface grade, or if the trench is under pavement, 18 inches below the roadway subgrade.

- C. **Marking Tape Installation:** Marking tape shall be installed as indicated in the Approved Drawings.
- D. **Final Backfill:** Final backfill is all backfill in the trench cross-sectional area within 18 inches of finished grade, or if the trench is under pavement, all backfill within 18 inches of the roadway subgrade.

3.7 FILL AND EMBANKMENT CONSTRUCTION

- A. Where embankment or structure fills are constructed over pipelines, the first 4 feet of fill over the pipe shall be constructed using light placement and compaction equipment that does not damage the pipe. Heavy construction equipment shall maintain a minimum distance from the edge of the trench equal to the depth of the trench until at least 4 feet of fill over the pipe has been completed.

3.8 EROSION CONTROL

- A. The CONTRACTOR shall be responsible for preventing erosion of disturbed areas and for preventing the movement of any eroded materials from the project site into adjacent areas or waterways.

- END OF SECTION -

SECTION 02225 – CUT-OFF WALLS

PART 1 -- GENERAL

1.1 THE REQUIREMENT

- A. The CONTRACTOR shall provide cutoff walls and drain piping, complete and operable, in accordance with the Development Agreement.

1.2 REFERENCE SPECIFICATIONS, CODES, AND STANDARDS

ASTM D1785 Poly (Vinyl Chloride) (PVC) Plastic Pipe, Schedules 40, 80, and 120

PART 2 -- PRODUCTS

2.1 SOIL CEMENT

- A. Soil cement shall be Type J material as defined in Section 02200 – Earthwork.
- B. As an alternative to soil cement, the CONTRACTOR may use bags of ready-mix concrete. The concrete shall have a minimum 28-day compressive strength of 2,000 psi. The bags shall remain sealed and shall be stacked in courses using a standard running bond pattern. The bags shall be keyed into the trench wall a minimum of 1 foot, as shown in the Approved Drawings.

2.2 PERFORATED PVC PIPE

- A. Perforated PVC pipe shall be made from all new rigid unplasticized polyvinyl chloride and shall be Normal Impact Class 12454-B, Schedule 80, conforming to ASTM D1785. All perforated pipe shall have a slotted or hole pattern as shown in the Drawings. Slots shall be approximately 0.25-inches wide by 2-inches long. Holes shall be drilled approximately 0.5-inch in diameter. Elbows and tees shall be of the same material as the pipe. Elbows and tees shall not be perforated. Joint design shall be for solvent-welded construction to the pipe manufacturer's specifications.

2.3 SOLID WALL PVC PIPE

- A. PVC pipe shall be made from all new rigid unplasticized polyvinyl chloride and shall be Normal Impact Class 12454-B, Schedule 80, conforming to ASTM D1785. Elbows and tees shall be of the same material as the pipe. Joint design shall be for solvent-welded construction to the pipe manufacturer's specifications.

2.4 FILTER FABRIC

- A. Filter fabric shall conform to the requirements for underdrains given in of Section 88-1.03 of the Standard Specifications.

PART 3 – INSTALLATION

3.1 GENERAL

- A. Excavation and backfill shall conform to the requirements of Section 02200 – Earthwork.

3.2 SOIL CEMENT

- A. Materials for soil cement shall be thoroughly machine-mixed in a rotary drum or similar mixing device. Mixing shall continue until the cement and water are thoroughly dispersed throughout the soil cement mix.
- B. Soil cement shall be placed in the trench within one hour after mixing. Soil cement that has sat for longer than one hour shall be discarded. Reconstituted soil cement shall not be used.
- C. Backfill shall not be placed on or adjacent to soil cement until the soil cement has cured for a minimum of 8 hours.

3.3 DRAIN PIPING

- A. Piping shall be laid to the dimensions and slopes shown on the Approved Drawings. After installation of the piping, the piping shall be thoroughly flushed to remove any dirt, rock or other debris.

3.4 FILTER FABRIC

- A. Surface to receive filter fabric shall be free of loose material and sharp objects that may damage the fabric.
- B. Filter fabric damaged during installation shall be completely replaced or repaired by placing a patch of fabric over the damaged area. The patch shall be large enough to overlap the damaged area by at least 12-inches in all directions.

- END OF SECTION -

SECTION 02460 - A.C. PAVEMENT AND BASE

PART 1 -- GENERAL

1.1 THE REQUIREMENT

- A. The CONTRACTOR shall provide asphalt concrete pavement and base, complete and in place, in accordance with the Development Agreement.
- B. Asphalt concrete pavement shall be plant-mixed asphalt concrete and shall conform to the requirements of this Section.

1.2 REFERENCE SPECIFICATIONS, CODES, AND STANDARDS

ASTM C127	Standard Test Method for Specific Gravity and Absorption of Coarse Aggregate
ASTM C131	Standard Test Method for Resistance to Degradation of Small-Size Coarse Aggregate by Abrasion and Impact in the Los Angeles Machine
ASTM D 2027	Cutback Asphalt (Medium Curing Type)
California Test 217	Method of Test for Sand Equivalent
California Test 229	Method of Test for Durability Index
California Test 301	Method Test for Resistance "R" Value of Treated and Untreated Bases, Subbases and Basement Soils (Stabilometer)

1.3 CONTRACTOR SUBMITTALS

- A. The CONTRACTOR shall furnish submittals in accordance with Section 01300 – Contractor Submittals.
- B. The CONTRACTOR shall submit materials testing reports and other pertinent information certifying that the AC pavement conforms to the requirements of the Contract Documents.
- C. **Suitability Tests of Proposed Materials:** Tests for conformance with the Specifications shall be performed prior to start of the WORK. Results of all tests shall be submitted to the DISTRICT for approval. Materials to be tested shall include aggregate base, coarse and fine aggregate for paving mixtures, mineral filler, and asphalt cement.

PART 2 -- PRODUCTS

2.1 AGGREGATE BASE

- A. Aggregate base shall conform to the requirements given for Class 2 aggregate base in Section 26 of the Standard Specifications.

2.2 TACK COAT

- A. Tack coat shall be bituminous binder (SS-1H) or AR-1000 paving asphalt.

2.3 PLANT MIXED ASPHALT

- A. Asphalt concrete shall be Caltrans ½" Maximum, Medium (Type B) with PG 64-16 Asphalt Binder or an approved equal. The top lift of AC shall contain "BoniFibers" as produced by Kapejo, Inc, or an approved equal at a rate of 5 pounds of fiber per ton of AC with an additional 0.25% of asphalt content per ton of mix in accordance with the manufacturer's recommendations and specifications.

2.4 PAVEMENT MARKING PAINT

- A. Pavement marking paint shall be a product specifically formulated for use on asphalt concrete pavement and shall have a proven record of performance and durability.

2.5 ASPHALT EMULSION PAINT BINDER

- A. Asphalt emulsion paint binder shall be Grade SS-1, as specified in Section 94 of the Standard Specifications.

PART 3 -- EXECUTION

3.1 SUBGRADE PREPARATION

- A. The subgrade shall be prepared in accordance with Section 02200 - Earthwork as applicable to roadways and embankments. The surface of the subgrade after compaction shall be hard, uniform, smooth and true to grade and cross-section. Subgrade for pavement shall not vary more than 0.02-foot from the indicated grade and cross section. Subgrade for base material shall not vary more than 0.04-foot from the indicated grade and cross section.

3.2 AGGREGATE BASE

- A. Aggregate base shall be provided where indicated to the thickness indicated. Placement of aggregate base shall conform to the requirements of Section 26 of the Standard Specifications.

3.3 TACK COAT

- A. A tack coat shall be applied to existing paved surfaces where new asphalt concrete is to be placed on existing pavement. It shall also be applied to the contact surfaces of all cold pavement joints, curbs, gutters, manholes and the like immediately before the adjoining asphalt pavement is placed. Care shall be taken to prevent the application of tack coat material to surfaces that will not be in contact with the new asphalt concrete pavement. Tack coat asphalt shall be spray-applied at the rate of approximately 0.05 gal/sq yd.

3.4 ASPHALT CONCRETE

- A. Asphalt concrete shall not be placed when the atmospheric temperature is below 10°C or during unsuitable weather.
- B. The asphalt concrete shall be evenly spread upon the base to such a depth that, after rolling, it will be of the required cross section and grade of the course being constructed.

- C. Spreading, once commenced, shall be continued without interruption.

3.5 PAVEMENT MARKING

- A. Pavement marking paint shall be applied where indicated only when the pavement surface is dry and clean, and when the air temperature is above 10° C. All equipment used in the application of pavement marking shall produce stripes and markings of uniform quality with clean and well-defined edges that conform to the details and dimensions indicated. Drips, overspray, improper markings, and paint material tracked by traffic shall be immediately removed from the pavement surface by methods previously reviewed by the DISTRICT.

- END OF SECTION -

SECTION 02565 - DUCTILE IRON PIPE

PART 1 -- GENERAL

1.1 THE REQUIREMENT

- A. The CONTRACTOR shall provide ductile iron pipe and all appurtenant work, complete in place, in accordance with the Development Agreement.

1.2 REFERENCE SPECIFICATIONS, CODES, AND STANDARDS

ASTM A307	Carbon Steel Bolts and Studs, 60,000 PSI Tensile Strength
ASTM A536	Ductile Iron Castings
ASTM C150	Portland Cement
AWWA C104	Cement-Mortar Lining for Ductile-Iron Pipe and Fittings for Water
AWWA C110	Ductile-Iron and Gray-Iron Fittings, 3-in. - 48 in., for Water
AWWA C111	Rubber-Gasket Joints for Ductile-Iron Pressure Pipe and Fittings
AWWA C115	Flanged Ductile-Iron Pipe with Ductile Iron or Gray-Iron Threaded Flanges
AWWA C150	Thickness Design of Ductile-Iron Pipe
AWWA C151	Ductile-Iron Pipe, Centrifugally Cast, for Water
AWWA C153	Ductile-Iron Compact Fittings for Water Service
AWWA C219	Bolted, Sleeve-Type Couplings for Plain-End Pipe
AWWA C550	Protective Epoxy Interior Coatings for Valves and Hydrants
AWWA C600	Installation of Ductile Iron Water Mains and Their Appurtenances

1.3 CONTRACTOR SUBMITTALS

- A. The CONTRACTOR shall furnish submittals in accordance with Section 01300 – Contractor Submittals.
- B. The CONTRACTOR shall submit the following information:
 - 1. Catalog cuts of pipe, fittings and specials indicating the size, manufacturer, end joints, lining and coating and pressure rating.

2. Catalog cuts of pipeline marking tape indicating the size, color, manufacturer and material.
3. Catalog cuts of prefabricated riser assemblies indicating the size, material, manufacturer, end joints, lining and coating and pressure rating.

PART 2 -- PRODUCTS

2.1 GENERAL

- A. Mortar-lined ductile iron pipe shall conform to AWWA C104 and C151, subject to the following supplemental requirements. The pipe shall be of the diameter and class shown in the Approved Drawings, shall be furnished complete with all necessary rubber gaskets, specials and fittings.
- B. Pipe materials shall conform to the requirements of AWWA C151.
- C. **Handling and Storage:** The pipe shall be handled by devices acceptable to the DISTRICT, designed and constructed to prevent damage to the pipe coating/exterior. The use of equipment, which might injure the pipe coating/exterior, will not be permitted. Stockpiled pipe shall be suitably supported and shall be secured to prevent accidental rolling. All other pipe handling equipment and methods shall be acceptable to the DISTRICT.
- D. **Laying Lengths:** Maximum pipe laying lengths shall be 20 feet with shorter lengths provided as required by the Drawings.
- E. **Closures and Correction Pieces:** Closures and correction pieces shall be provided as required so that closures may be made due to different headings in the pipe laying operation and so that correction may be made to adjust the pipe laying to conform to pipe stationing shown on the Drawings. The locations of correction pieces and closure assemblies shall be acceptable to the DISTRICT.

2.2 FITTINGS AND SPECIALS

- A. Fittings for ductile iron pipe shall conform to the requirements of AWWA C153 or AWWA C110. Fittings shall have a minimum pressure rating of 250 psi. Flanged cast iron fittings with a pressure rating of 150 psi shall not be used. Fittings shall be either cement-mortar lined and asphalt coated as described in this Specification, or epoxy lined and coated in accordance with AWWA C550.
- B. The pressure rating of fittings shall be stamped or cast directly on the exterior of the fitting by the manufacturer. Any fittings where the pressure rating has not been so indicated shall be rejected by the DISTRICT and removed from the site.
- C. Restrained joints at fittings and specials shall be as described in Article 2.3 of this Specification.
- D. Specials shall be as specified herein and as indicated on the Approved Drawings.
 1. Sleeve couplings shall conform to the requirements of AWWA C219. Sleeve and end rings shall conform to ASTM A536 and shall be epoxy lined and coated in accordance with AWWA C550. Gaskets shall conform to AWWA C219. Sleeve

couplings shall have a pressure rating of no less than 250 psi and shall be clearly marked with the rated pressure. The following products are acceptable for sleeve couplings sized 2-inch to 12-inch:

- a. Romac Industries, Inc., Style 501
 - b. Smith-Blair, Product 441
 - c. Ford Meter Box Company, Inc., Style FC1
 - d. or approved equal.
2. Flanged coupling adapters shall conform to the requirements of AWWA C219. Flanged body and end rings shall conform to ASTM A536 and shall be epoxy lined and coated in accordance with AWWA C550. Gaskets shall conform to AWWA C219. CONTRACTOR shall be responsible for matching bolt patterns of flanged coupling adapter with connecting pipe or appurtenances. Flanged coupling adapters shall have a pressure rating of no less than 200 psi and shall be clearly marked with the rated pressure. The following products are acceptable for flanged coupling adapters sized 3-inch to 12-inch:
- a. Romac Industries, Inc., Style "FCA501"
 - b. Dresser, Style 227
 - c. Smith-Blair, Product 912
 - d. Or approved equal.

E. Nuts and Bolts:

1. Nuts and bolts for flanges and T-bolts for mechanical joint fittings shall be ASTM A307, Grade A or B carbon steel. Nuts and bolts shall be factory hot-dip galvanized, zinc-plated, epoxy-coated or fluoropolymer-coated. Bare carbon steel shall not be allowed. Threads on galvanized bolts and nuts shall be formed with suitable taps and dies such that they retain their normal clearance after hot-dip galvanizing. The nuts shall be capable of developing the full strength of the bolts. Threads shall be Coarse Thread Series conforming to the requirements of the American Standard for Screw Threads.
2. For items that are packaged from the factory with bare carbon steel nuts and bolts, the factory provided items shall be replaced with nuts and bolts of equal or better strength that conform to the coating requirements of this Section. The application of coatings or paints in the field by brush or spray shall not be adequate to satisfy the requirements of this Section.
3. Uncoated nuts and bolts made of high-strength low-alloy steel conforming to the requirements of ASTM A242 or ASTM A588 shall be allowed provided that there is a grade marking applied to the item at the factory. In order to be acceptable, the DISTRICT must be able to confirm the type of steel by a simple visual inspection of an assembled joint. The application of a manufacturer's insignia alone shall not be acceptable.

- a. Romac has submitted documentation to the DISTRICT confirming that uncoated bolting materials supplied with Romac products conform to the requirements of ASTM A242 or ASTM A588. Uncoated bolting materials included inside factory sealed packages from Romac shall be acceptable even though they do not include a grade marking.
 - b. The acceptance of uncoated and unmarked bolting materials shall apply to bolting materials supplied by Romac only. Uncoated bolting materials supplied with products by other manufacturers shall be subject to the full requirements of this Section.
4. The requirements for nuts and bolts given in this Article shall also apply to threaded rods, carriage bolts, studs and any similar items used to construct water system piping in a buried application.
 5. In the event that the CONTRACTOR proposes to supply fastener materials that do not comply with the above requirements, the CONTRACTOR shall note this non-conformance in the Shop Drawing submittal. The DISTRICT shall consider such submittals on a case-by-case basis.

2.3 JOINTS

- A. **Joint Design:** Ductile iron pipe and fittings shall be furnished with mechanical joints, push-on joints, flanged joints, and restrained joints, as required.
 1. Mechanical joints and push-on joints shall conform to AWWA C111.
 2. Flanged joints shall conform to AWWA C115.
 3. Restrained joints shall be made up using one of the following:
 - a. "Field-Lok" gaskets by U.S. Pipe
 - b. "Gripper" gaskets by Gripper Gasket Company
 - c. Wedge-type retainer glands - EBAA "Megalug", EBAA "Megaflange", Sigma "One-Lok", or Stargrip Series 3000
 - d. "One-Bolt" fittings by One Bolt Incorporated
 - e. "GripRing" Pipe Restraints by Romac Industries.
 - f. Foster Adaptors by Infact Corporation
 - g. Restraint harnesses - EBAA Series 1100 HD or EBAA Series 1700
 - h. MJ Field Lok Restraints by US Pipe
- B. **Joint Restraint:** Joints at all fittings and valves shall be restrained. Wherever possible, the CONTRACTOR shall install full lengths of pipe (18 feet long minimum) on either side of fittings and valves. Straight runs of pipe on either side of a fitting shall be restrained by one of two methods.

1. The CONTACTOR may pour concrete thrust blocks as indicated in the Development Agreement.
2. The CONTRACTOR may restrain in-line pipe joints by the use of methods indicated in this Section.
 - a. For an elbow, the length of pipe in feet on each side of the elbow that the pipe joints must be restrained is given in Detail W-8 (latest revision).
 - b. For a tee, the length of pipe in feet on the branch run that the pipe joints must be restrained is given in Detail W-8 (latest revision). The pipe along the through run may be unrestrained, provided that another nearby fitting does not require restrained pipe.
 - c. For a dead end pipe run with either an end cap or plug, the length of pipe in feet from the end cap or plug that the pipe joints must be restrained is given in Detail W-8 (latest revision).
- C. For bell-and-spigot ends with rubber gaskets, the clearance between the bells and spigots shall be such that when combined with the gasket groove configuration and the gasket itself, will provide watertight joints under all operating conditions when properly installed.
- D. **Flange Gaskets:** Gaskets for flanged joints shall be 1/8-inch thick synthetic rubber conforming with AWWA C115. Gaskets shall be either full face or ring gaskets with integral ribs. Flat ring gaskets shall not be acceptable. Gaskets shall be rated for long-term exterior above-grade installation by the manufacturer.

2.4 CEMENT-MORTAR LINING

- A. **Cement-Mortar Lining for Shop Application:** Interior surfaces of all ductile iron pipe, fittings, and specials shall be cleaned and lined in the shop with cement-mortar lining applied centrifugally in conformity with AWWA C104. During the lining operation and thereafter, the pipe shall be maintained in a round condition by suitable bracing or strutting. Every precaution shall be taken to prevent damage to the lining. If lining is damaged or found faulty at delivery site, the damaged or unsatisfactory portions shall be replaced with lining conforming to these Specifications.
- B. **Cement:** Cement for mortar lining shall be Type V, conforming to the requirements of AWWA C104. Cement shall not originate from kilns that burn metal-rich hazardous waste fuel, nor shall fly ash or pozzolan be used as a cement replacement.
- C. The minimum lining thickness shall be as follows:

Nominal Pipe Diameter (in)	Minimum Lining Thickness (in)
3-12	1/8
14-24	3/16

- D. **Protection of Pipe Lining/Interior:** All shop-applied cement mortar lining shall be given a seal coat of asphaltic material in conformance with AWWA C104.

2.5 EXTERIOR COATING

- A. **Exterior Coating of Buried Piping:** The exterior coating shall be an asphaltic coating approximately 1 mil thick.

2.6 PIPELINE MARKING TAPE

- A. Pipeline marking tape shall have a minimum thickness of 5 mils, and shall be impervious to alkalis, acids, chemicals and solvents. Tape shall have a 50-gauge solid aluminum foil core laminated between two layers of inert plastic film. Tape shall have a minimum width of three inches and a minimum tensile strength of 100 pounds per 3-inch wide strip.
- B. Pipeline marking tape shall be colored blue and shall bear a continuously printed message in permanent black letters. Lettering shall be 1-inch tall and shall read "CAUTION – WATER LINE BURIED BELOW".

2.7 PIPELINE LOCATOR WIRE

- A. Pipeline locator wire shall be No. 10 AWG solid copper wire with THWN insulation. Splice connectors shall be rated for wet location/direct burial installation. All splices shall be covered with heat-activated shrink-wrap tubing or heavy mastic tape to create a watertight connection.

2.8 THRUST AND ANCHOR BLOCKS

- A. Thrust and anchor blocks shall be constructed of portland cement concrete as specified in Section 90 of the Standard Specifications. The minimum 28-day compressive strength shall be 2,000 psi (14 MPa). Maximum aggregate size shall be 1-1/2 inch (37.5 mm) and maximum slump shall be 4 inches (10 mm). Air entrainment is not required.

PART 3 -- EXECUTION

3.1 INSTALLATION OF PIPE

- A. **Handling and Storage:** All pipe, fittings and specials shall be carefully handled and protected against damage, impact shocks, and free fall. All pipe handling equipment shall be acceptable to the DISTRICT. Pipe shall not be placed directly on rough ground but shall be supported in a manner that will protect the pipe against injury whenever stored at the trench site or elsewhere. No pipe shall be installed where the lining or coating show defects that may be harmful as determined by the DISTRICT. Such damaged lining or coating shall be repaired, or a new undamaged pipe shall be furnished and installed.
- B. All pipe damaged prior to Unconditional Acceptance by the DISTRICT shall be repaired or replaced by the CONTRACTOR. Methods of repair shall be subject to approval by the DISTRICT.
- C. The CONTRACTOR shall inspect each pipe and fitting prior to installation to insure that there are no damaged portions of the pipe.
- D. Before placement of pipe in the trench, each pipe or fitting shall be thoroughly cleaned of any foreign substance, which may have collected thereon and shall be kept clean at all

times thereafter. For this purpose, the openings of all pipes and fittings in the trench shall be closed during any interruption to the WORK.

- E. **Pipe Laying:** The pipe shall be installed in accordance with AWWA C600. Pipe shall be laid directly on the bedding material. Blocking shall not be permitted, and the bedding shall be such that it forms a continuous, solid bearing for the full length of the pipe. Excavations shall be made as needed to facilitate removal of handling devices after the pipe is laid. Bell holes shall be formed at the ends of the pipe to prevent point loading at the bells or couplings. Excavation shall be made as needed outside the normal trench section at field joints to permit adequate access to the joints for field connection operations and for application of coating on field joints.
- F. Where necessary to raise or lower the pipe due to unforeseen obstructions or other causes, the DISTRICT may change the alignment and/or the grades. Such changes shall be made by the deflection of joints or by the use of additional fittings. However, in no case shall the deflection in the joint exceed the maximum deflection recommended by the pipe manufacturer.
- G. Except for short runs that may be permitted by the DISTRICT, pipes shall be laid uphill on grades exceeding 10 percent. Pipe that is laid on a downhill grade shall be blocked and held in place until sufficient support is furnished by the following pipe to prevent movement. All bends shall be properly installed as shown.
- H. **Cold Weather Protection:** No pipe shall be installed upon a foundation into which frost has penetrated or at any time that there is a danger of the formation of ice or penetration of frost at the bottom of the excavation. No pipe shall be laid unless it can be established that the trench will be backfilled before the formation of ice and frost occurs.
- I. **Pipe and Specials Protection:**
 - a. Before placement of pipe in the trench, each pipe or fitting shall be thoroughly cleaned of any foreign substance, which may have collected thereon and shall be kept clean at all times thereafter. The openings of all pipe and specials shall be protected with suitable bulkheads to prevent unauthorized access by persons, animals, water or any undesirable substance.
 - b. The CONTRACTOR shall utilize plugs, caps or similar devices manufactured specifically for the purpose of sealing pipe ends. The use of plywood, traffic cones or other items not specifically intended for this use shall not be allowed. These protective devices shall be installed during any interruption to the WORK.
 - c. In the event that water, soil or other deleterious material enters the pipe, the CONTRACTOR shall take immediate steps to remove it. Such steps shall include sweeping, vacuuming, flushing, pigging or any other method necessary to clean the interior of the pipe to the satisfaction of the DISTRICT.
 - d. Trenches shall be kept free of water until joints have been properly made. The CONTRACTOR shall take all necessary precautions to prevent flotation of the pipe. Any pipe and fittings displaced by flotation shall be removed and reinstalled.

3.2 TRENCHING AND BACKFILL

- A. Trench excavation and backfill shall conform to the requirements of Section 02200 - Earthwork.

3.3 INSTALLATION OF MARKING TAPE AND LOCATOR WIRE

- A. Marking tape shall be installed as indicated on the Standard Details.
- B. Locator wire shall be installed as indicated on the Standard Details.
- C. Locator wire shall be terminated in valve and service boxes as indicated on the Standard Details.

3.4 CONNECTIONS TO EXISTING WATERLINES

- A. The CONTRACTOR shall locate all underground improvements and install the pipelines to the depths indicated. Where the new work is to be connected to existing pipelines, the CONTRACTOR shall make its arrangements with the DISTRICT a minimum of 4 working days in advance of the connections, to allow adequate time for dewatering of the existing line, if necessary, and shall expedite the work to minimize any water outages.
- B. If, in the opinion of the DISTRICT, the CONTRACTOR is not adequately prepared, does not have adequate manpower and equipment, or likely cannot complete the scheduled connection within the planned time, the DISTRICT may postpone the scheduled connection until a later date when the CONTRACTOR can be properly prepared.

3.5 ANODE INSTALLATION

- A. Anodes shall be installed on existing steel pipeline to remain in service, 4-inch in diameter and larger, at all locations where the coating of the steel pipeline has been cut, damaged, or removed during construction.
 - 1. The CONTRACTOR shall perform all excavation and backfill work.
 - 2. The DISTRICT shall furnish and install the anodes.
 - 3. The CONTRACTOR shall contact the DISTRICT a minimum of 5 working days in advance, when feasible, to schedule the installation of the anode.

3.6 FIRE SPRINKLER LATERALS

- A. Fire sprinkler laterals 4-inch in diameter and larger may be constructed of either ductile iron or PVC pipe. However, all portions of the buried lateral located underneath a structure shall be constructed of ductile iron only. The ductile iron portion of the lateral shall extend eight feet beyond the edge of the foundation of the structure. From that point, to the point of connection to the water main, the lateral may be constructed of either ductile iron or PVC.
- B. The CONTRACTOR may utilize a prefabricated riser assembly for the portion of the sprinkler laterals underneath the foundation wall and floor slab. The CONTRACTOR shall submit the proposed prefabricated riser assembly for review and approval.

- C. The fire sprinkler lateral shall be properly restrained to the prefabricated riser assembly (using thrust blocks or mechanical devices) as required by these Construction Standards and the manufacturer's recommendations. For prefabricated riser assemblies that have a push-on joint with ear lugs, the riser shall be restrained to the lateral pipe using a restraint harness connected to the ear lugs.
- D. The customer-owned portion of the fire sprinkler lateral shall be subject to pressure testing and disinfection as described in the ***Water System Construction Standards***.

3.7 ASSEMBLY OF JOINTS WITH MECHANICAL DEVICES

- A. All joints with mechanical devices (EBAA Mega-lugs, Sigma One-Loks, Romac Grip-Rings, etc.) shall be assembled in accordance with the manufacturer's recommendations using equipment and tools as recommended by the manufacturer.
- B. The DISTRICT has no objection to the use of impact sockets (either pneumatic or electric) provided that they are acceptable to the manufacturer. In the event that the CONTRACTOR utilizes impact sockets to assemble joints, the CONTRACTOR shall have on-site, an adjustable torque-indicating wrench to verify that the torque settings of the impact socket are correct. Impact sockets **SHALL NOT** be used to tighten the torque-limiting twist-off nuts that secure the wedges on wedge-type retainer glands (EBAA Mega-lugs or similar items).

3.8 THRUST BLOCKS

- A. Prior to placing thrust blocks, the CONTRACTOR shall wrap all bolts near the thrust block with protective plastic sheeting to prevent the bolts from being embedded within the concrete.

3.9 FIELD TESTING AND DISINFECTION

- A. Field testing and disinfection and water mains shall conform to the requirements of Section 02643 - Water Pipeline Testing and Disinfection.

- END OF SECTION -

SECTION 02597 - PVC PRESSURE PIPE

PART 1 -- GENERAL

1.1 THE REQUIREMENT

- A. The CONTRACTOR shall furnish polyvinyl chloride (PVC) pressure pipe, complete in place, in accordance with the Development Agreement.

1.2 REFERENCE SPECIFICATIONS, CODES, AND STANDARDS

ASTM D2000	Classification System for Rubber Products in Automotive Applications
ASTM D2584	Test Method for Ignition Loss of Cured Reinforced Resins
ASTM F477	Standard Specification for Elastomeric Seals (Gaskets) for Joining Plastic Pipe
AWWA C605	Underground Installation of Polyvinyl Chloride (PVC) Pressure Pipe and Fittings for Water
AWWA C900	Polyvinyl Chloride (PVC) Pressure Pipe, and Fabricated Fittings, 4-inch Through 12-inch for Water Distribution
AWWA M23	PVC Pipe – Design and Installation
UniBell B-13	Recommended Standard Performance Specification for Joint Restraint Devices for Use with Polyvinyl Chloride (PVC) Pipe

1.3 CONTRACTOR SUBMITTALS

- A. The CONTRACTOR shall furnish submittals in accordance with Section 01300 – Contractor Submittals.
- B. The CONTRACTOR shall submit the following information:
 - 1. Catalog cuts of pipe, fittings and specials indicating the size, manufacturer, end joints, lining and coating and pressure rating.
 - 2. Catalog cuts of pipeline marking tape indicating the size, color, manufacturer and material.
 - 3. Catalog cuts of prefabricated riser assemblies indicating the size, material, manufacturer, end joints, lining and coating and pressure rating.

PART 2 -- PRODUCTS

2.1 GENERAL

- A. PVC pressure pipe shall conform to the applicable requirements of AWWA C900 subject to additional requirements herein.

- B. Pipe shall be of the nominal diameter indicated in the Approved Drawings, with a DR-14 (305 psi) rating. Pipe shall be furnished complete with rubber gaskets and all other specials and fittings as required in the Contract Documents.
- C. **Handling and Storage:** The pipe shall be handled by devices acceptable to the DISTRICT, designed and constructed to prevent damage to the pipe. The use of equipment which might injure the pipe will not be permitted. Stockpiled pipe shall be suitably supported and shall be secured to prevent accidental rolling. All other pipe handling equipment and methods shall be acceptable to the DISTRICT.
- D. **Laying Lengths:** Maximum pipe laying lengths shall be 20 feet with shorter lengths provided as required.
- E. **Closures and Correction Pieces:** Closures and correction pieces shall be provided as required so that closures may be made due to different headings in the pipe laying operation and so that correction may be made to adjust the pipe laying to conform to pipe stationing shown on the Drawings. The locations of correction pieces and closure assemblies shall be acceptable to the DISTRICT.

2.2 FITTINGS AND SPECIALS

- A. Fittings for PVC pipe shall be ductile iron and shall conform to the requirements of Section 02565 – Ductile Iron Pipe.
- B. Specials shall be as indicated in Section 02565 – Ductile Iron Pipe and as indicated on the Approved Drawings.

2.3 JOINTS

- A. **Joints:** Joints for the buried PVC pipe shall be an integral bell and spigot manufactured on the pipe.
- B. Joints at all fittings and valves shall be restrained. In addition, all joints located closer than 16 feet to a fitting or valve shall be restrained. Wherever possible, the CONTRACTOR shall install full lengths of pipe (18 feet long minimum) on either side of fittings and valves
- C. **Restrained Joints:** Where required, restrained joints shall be made up with either thrust blocks or mechanical devices. Mechanical devices shall comply with the requirements of UniBell B-13. Mechanical devices for joint restraint shall be one of the following:
 1. Wedge-type retainer glands – “EBAA Megalug”, EBAA “Megaflange”, Sigma “One-Lok” or Stargrip Series 4000.
 2. “One-Bolt” fittings by One Bolt Incorporated
 3. “GripRing” pipe restraints by Romac Industries
 4. Restraint harnesses - EBAA Iron Series 1500, Romac Series 600, Sigma “PV-Lok” or Star Series 1100C.
 5. MJ Field Lok Restraints by US Pipe

- D. **Joint Restraint:** Joints at all fittings and valves shall be restrained. Wherever possible, the CONTRACTOR shall install full lengths of pipe (18 feet long minimum) on either side of fittings and valves. Straight runs of pipe on either side of a fitting shall be restrained by one of two methods.
- 1) The CONTRACTOR may pour concrete thrust blocks as indicated in the Standard Details.
 - 2) The CONTRACTOR may restrain in-line pipe joints by the use of methods indicated in this Section.
 - a. For an elbow, the length of pipe in feet on each side of the elbow that the pipe joints must be restrained is given in Detail W-8 (latest revision).
 - b. For a tee, the length of pipe in feet on the branch run that the pipe joints must be restrained is given in Detail W-8 (latest revision). The pipe along the through run may be unrestrained, provided that another nearby fitting does not require restrained pipe.
 - c. For a dead end pipe run with either an end cap or plug, the length of pipe in feet from the end cap or plug that the pipe joints must be restrained is given in Detail W-8 (latest revision).
- E. For bell-and-spigot ends with rubber gaskets, the clearance between the bells and spigots shall be such that when combined with the gasket groove configuration and the gasket itself, will provide watertight joints under all operating conditions when properly installed.
- F. **Joint Deflection and Longitudinal Bending:** While installing PVC pipe, the CONTRACTOR may achieve minor offsets through the use of longitudinal bending. PVC pipe joints shall not be deflected to achieve offsets. The table below gives parameters for allowable bending of PVC pipe.

Pipe Size	Minimum Radius of -- Curvature, feet	Maximum Offset for a Single Piece of Pipe, inches
4-inch	100	24
6-inch	144	17
8-inch	188	13
10-inch	232	10
12-inch	275	9

2.4 PIPELINE MARKING TAPE

- A. Pipeline marking tape shall conform to the requirements of Section 02565 – Ductile Iron Pipe.

2.5 PIPELINE LOCATOR WIRE

- A. Pipeline locator wire shall conform to the requirements of Section 02565 – Ductile Iron Pipe.

2.6 THRUST AND ANCHOR BLOCKS

- A. Thrust and anchor blocks shall conform to the requirements of Section 02565 – Ductile Iron Pipe.

PART 3 -- EXECUTION

3.1 GENERAL

- A. Laying, jointing, testing for defects and for leakage shall be performed in the presence of the DISTRICT, and shall be subject to approval before acceptance. Material found to have defects will be rejected and the CONTRACTOR shall promptly remove such defective materials from the Site.
- B. Installation shall conform to the requirements of AWWA M23, AWWA C605, instructions furnished by the pipe manufacturer, and to the supplementary requirements herein. Wherever the provisions of this Section and the aforementioned requirements are in conflict, the more stringent provision shall apply.

3.2 HANDLING AND STORAGE

- A. **Handling:** Pipe, fittings and accessories shall be carefully inspected before and after installation and those found defective shall be rejected. Pipe and fittings shall be free from fins and burrs. Before being placed in position, pipe, fittings, and accessories shall be cleaned, and shall be maintained in a clean condition. Proper facilities shall be provided for lowering sections of pipe and appurtenances into trenches. Under no circumstances shall pipe, fittings or any other material be dropped or dumped into trenches.
- B. **Storage:** Pipe shall be stored, if possible, at the Site in unit packages provided by the manufacturer. Caution shall be exercised to avoid compression damage or deformation to bell ends of the pipe. Pipe shall be stored in such a way as to prevent sagging or bending and be protected from exposure to direct sunlight by covering with an opaque material while permitting adequate air circulation above and around the pipe. Gaskets shall be stored in a cool, dark place out of the direct rays of the sun, preferably in original cartons.

3.3 TRENCHING AND BACKFILL

- A. Trench excavation and backfill shall conform to the requirements of Section 02200 - Earthwork.

3.4 INSTALLATION

- A. Bell-and-spigot pipe shall be laid with the bell end pointing in the direction of laying. On slopes of 10 percent or greater, laying shall begin at the bottom of the slope and proceed upward. Pipe trenches shall be graded in straight lines, taking care to avoid the formation of any dips or low points.
- B. Pipe shall not be laid when the conditions of trench or weather are unsuitable. Whenever pipe laying is discontinued, or at the end of each days work, open ends of pipe shall be closed temporarily with wood blocks or bulkheads. Blocks or bulkheads shall not be removed unless the trench is dry.

- C. The pipeline vertical alignment shall maintain a minimum depth to the top of pipe as noted in the Standard Details. The pipeline depth shall be increased as necessary to provide a minimum of 12-inches of vertical clearance between the top of the pipe and any underground structure or utility. The depth shall also be increased as directed by the DISTRICT to allow the pipe to be installed without grade changes, to eliminate fittings, air release valves or blow-offs. Pipelines beneath other utilities shall be located so that the other utility is located as close as possible to the mid-point between pipe joints.
- D. Pipe shall be supported at its proper elevation and grade, care being taken to secure firm and uniform support. Wood support blocking will not be permitted. The full length of each section of pipe and fittings shall rest solidly on the pipe bed, with recessed excavation to accommodate bells, joints, and couplings. Anchors and supports shall be provided where indicated and where necessary for fastening work into place. Fittings shall be independently supported.
- E. Joints shall be installed according to manufacturer's recommendations. The maximum combined deflection at any joint shall be in accordance with the manufacturer's recommendations and these specifications, whichever is more restrictive. Pipe lengths shall be selected so that the pipe can be installed through horizontal or vertical curves, or any combination thereof, without exceeding the maximum allowable joint deflection.
- F. **Pipe and Specials Protection:**
 - a. Before placement of pipe in the trench, each pipe or fitting shall be thoroughly cleaned of any foreign substance, which may have collected thereon and shall be kept clean at all times thereafter. The openings of all pipe and specials shall be protected with suitable bulkheads to prevent unauthorized access by persons, animals, water or any undesirable substance.
 - b. The CONTRACTOR shall utilize plugs, caps or similar devices manufactured specifically for the purpose of sealing pipe ends. The use of plywood, traffic cones or other items not specifically intended for this use shall not be allowed. These protective devices shall be installed during any interruption to the WORK.
 - c. In the event that water, soil or other deleterious material enters the pipe, the CONTRACTOR shall take immediate steps to remove it. Such steps shall include sweeping, vacuuming, flushing, pigging or any other method necessary to clean the interior of the pipe to the satisfaction of the DISTRICT.
 - d. Trenches shall be kept free of water until joints have been properly made. The CONTRACTOR shall take all necessary precautions to prevent flotation of the pipe. Any pipe and fittings displaced by flotation shall be removed and reinstalled.
- G. Pipe shall be cut by means of saws, power driven abrasive wheels, or pipe cutters, which will produce a square cut. No wedge-type roller cutters will be permitted. After cutting, the end of the pipe shall be beveled using a beveling tool, portable type sander, or abrasive disc.
- H. All pipe and fittings shall be properly restrained against horizontal and vertical movement due to internal pressure. Thrust blocks and anchor blocks shall be as indicated on the Standard Details. No loads shall be imposed on thrust blocks or anchor blocks until the concrete has reached a minimum compressive strength of 2,000 psi.

3.5 INSTALLATION OF MARKING TAPE AND LOCATOR WIRE

- A. Marking tape shall be installed as indicated on the Standard Details.
- B. Locator wire shall be installed as indicated on the Standard Details.
- C. Locator wire shall be terminated in valve and service boxes as indicated on the Standard Details.

3.6 CONNECTIONS TO EXISTING WATERLINES

- A. The CONTRACTOR shall locate all underground improvements and install the pipelines to the depths indicated. Where the new work is to be connected to existing pipelines, the CONTRACTOR shall make its arrangements with the DISTRICT a minimum of 4 working days in advance of the connections, to allow adequate time for dewatering of the existing line, if necessary, and shall expedite the work to minimize any water outages.
- B. If, in the opinion of the DISTRICT, the CONTRACTOR is not adequately prepared, does not have adequate manpower and equipment, or likely cannot complete the scheduled connection within the planned time, the DISTRICT may postpone the scheduled connection until a later date when the CONTRACTOR can be properly prepared.

3.7 ANODE INSTALLATION

- A. Anodes shall be installed on existing steel pipeline to remain in service, 4-inch in diameter and larger, at all locations where the coating of the steel pipeline has been cut, damaged, or removed during construction.
 - 1. The CONTRACTOR shall perform all excavation and backfill work.
 - 2. The DISTRICT shall furnish and install the anodes.
 - 3. The CONTRACTOR shall contact the DISTRICT a minimum of 5 working days in advance, when feasible, to schedule the installation of the anode.

3.8 FIRE SPRINKLER LATERALS

- A. Fire sprinkler laterals 4-inch in diameter and larger may be constructed of either ductile iron or PVC pipe. However, all portions of the buried lateral located underneath a structure shall be constructed of ductile iron only. The ductile iron portion of the lateral shall extend eight feet beyond the edge of the foundation of the structure. From that point, to the point of connection to the water main, the lateral may be constructed of either ductile iron or PVC.
- B. The CONTRACTOR may utilize a prefabricated riser assembly for the portion of the sprinkler laterals underneath the foundation wall and floor slab. The CONTRACTOR shall submit the proposed prefabricated riser assembly for review and approval. The fire sprinkler lateral shall be properly restrained (using thrust blocks or mechanical devices) as required by these Construction Standards and the manufacturer's recommendations.
- C. The customer-owned portion of the fire sprinkler lateral shall be subject to pressure testing and disinfection as described in the **Water System Construction Standards**.

3.9 ASSEMBLY OF JOINTS WITH MECHANICAL DEVICES

- A. All joints with mechanical devices (EBAA Mega-lugs, Sigma One-Loks, Romac Grip-Rings, etc.) shall be assembled in accordance with the manufacturer's recommendations using equipment and tools as recommended by the manufacturer.
- B. The DISTRICT has no objection to the use of impact sockets (either pneumatic or electric) provided that they are acceptable to the manufacturer. In the event that the CONTRACTOR utilizes impact sockets to assemble joints, the CONTRACTOR shall have on-site, an adjustable torque-indicating wrench to verify that the torque settings of the impact socket are correct. Impact sockets **SHALL NOT** be used to tighten the torque-limiting twist-off nuts that secure the wedges on wedge-type retainer glands (EBAA Mega-lugs or similar items).

3.10 THRUST BLOCKS

- A. Prior to placing thrust blocks, the CONTRACTOR shall wrap all bolts near the thrust block with protective plastic sheeting to prevent the bolts from being embedded within the concrete.

3.11 FIELD TESTING AND DISINFECTION

- A. Field testing and disinfection and water mains shall conform to the requirements of Section 02643 - Water Pipeline Testing and Disinfection.

- END OF SECTION -

SECTION 02640 – LARGE WATER SERVICE CONNECTIONS

PART 1 -- GENERAL

1.1 THE REQUIREMENT

- A. The CONTRACTOR shall provide water service connections for meters 1.5-inch and larger in accordance with the Development Agreement.
- B. Installations utilizing meters 1-inch and smaller shall comply with the requirements of Section 02641 – Water Service Connections.

1.2 REFERENCE SPECIFICATIONS, CODES, AND STANDARDS

ASTM A536	Ductile Iron Castings
ASTM D1785	Polyvinyl Chloride (PVC) Plastic Pipe, Schedules 40, 80, and 120
AWWA C700	Cold Water Meters – Displacement Type, Bronze Main Case
AWWA C800	Underground Service Line Valves and Fittings
Section 116875	California Health and Safety Code (Lead Free Brass)

PART 2 -- PRODUCTS

2.1 SERVICE SADDLES

- A. Service saddles shall comply with Section 02641 – Water Service Connections.

2.2 POLYETHYLENE TUBING

- A. Polyethylene tubing shall comply with Section 02641 – Water Service Connections.

2.3 DUCTILE IRON PIPE

- A. Ductile iron pipe shall comply with Section 02565 – Ductile Iron Pipe.

2.4 THREADED FITTINGS

- A. Threaded fittings shall comply with Section 02641 – Water Service Connections.

2.5 CURB BALL VALVES

- A. Curb ball valves shall comply with Section 02641 – Water Service Connections.

2.6 CORPORATION BALL VALVES

- A. Corporation ball valves shall comply with Section 02641 – Water Service Connections.

2.7 COUPLINGS

- A. Couplings shall comply with Section 02641 – Water Service Connections.

2.8 RESTRAINED FLANGED COUPLING ADAPTERS

- A. Restrained flanged coupling adapters shall be wedge type retainer glands as indicated in Section 02565 – Ductile Iron Pipe.

2.9 PIPE SUPPORTS

- A. Pipe supports shall be Standon Model S96 or approved equal, with the cradle sized appropriately for the pipe flange diameter.

2.10 METER INSTALLATIONS WITH 1.5-INCH OR 2-INCH METERS

- A. For single installations with 1.5-inch or 2-inch meters, boxes shall be precast concrete. All lids shall be permanently marked with the term “WATER” or “WATER METER.” In paved areas, areas subject to vehicular loading, or where deemed necessary by the DISTRICT, boxes rated for H-20 loading shall be provided. H-20 rated boxes shall have metal lids with bolting mechanisms to secure the lid and shall be furnished with bolts to secure the lid. Meter boxes shall be:

Location	Box	Extension	Lid
Non-Traffic Areas	Christy N48T Box	Christy B48x10	DFW B48C-4-LID
Traffic Rated Areas	Christy B3048 Box	Christy B3048x12	Christy B3048-63JH

Approved equals shall be accepted

- B. Meters idlers shall conform to AWWA C800. Meter idlers shall be of an alloy conforming to AWWA C800 and shall be “lead-free” in accordance with Section 116875 of the California Health and Safety Code. Meter idlers shall be:

Size	Meter Idler
1.5-inch	Ford Model IDLER-6-NL
2-inch	Ford Model IDLER-7-NL

Approved equals shall be accepted

- C. Meters flanges shall conform to AWWA C800. Meter flanges shall be of an alloy conforming to AWWA C800 and shall be “lead-free” in accordance with Section 116875 of the California Health and Safety Code. Meter flanges shall be designed for working pressures of 150 psi. Meter flanges shall be furnished with all necessary nuts, bolts and gaskets to accomplish a complete and functional installation. Meter flanges shall be:

Size	Meter Flange
1.5-inch	Ford Model CF31-66-NL
2-inch	Ford Model CF31-77-NL

Approved equals shall be accepted

- D. Flexible meter couplings shall conform to AWWA C800. Couplings shall be of ductile iron conforming to ASTM A536. Couplings shall be designed for working pressures of 175 psi. Couplings shall be furnished with all necessary nuts, bolts and gaskets to accomplish a complete and functional installation. Flexible meter couplings shall be:

Size	Flexible Meter Couplings
1.5-inch	Smith-Blair Model 926-000190-000
2-inch	Smith-Blair Model 926-000250-000

Approved equals shall be accepted

2.11 METER INSTALLATIONS WITH 3-INCH, 4-INCH OR 6-INCH METERS

- A. For single installations with 3-inch, 4-inch or 6-inch meters, boxes shall be precast concrete. Boxes shall have metal lids with bolting mechanisms to secure the lid and shall be furnished with bolts to secure the lid. All lids shall be permanently marked with the term "WATER." In paved areas, areas subject to vehicular loading, or where deemed necessary by the DISTRICT, boxes rated for H-20 loading shall be provided. Meter boxes shall be:

Location	Box	Extension	Lid
Non-Traffic Areas	Jensen 4878 Vault	As Required	4878ATI
Traffic Rated Areas	Jensen 4878 Vault	As Required	4878HD36

Approved equals shall be accepted

- B. Gate valves shall conform to the requirements of Section 15206 – Gate Valves. Gate valves shall be provided with handwheel operators by the manufacturer.
- C. Meter idlers for 3-inch, 4-inch or 6-inch meter installations shall be supplied by the DISTRICT.
- D. For 3-inch meter installations, wall penetrations around the 3-inch DI pipe shall be sealed with 10 links of LS-315-S by PSI Thunderline/Link-Seal.
- E. For 4-inch meter installations, wall penetrations around the 4-inch DI pipe shall be sealed with seven links of LS-410-S by PSI Thunderline/Link-Seal.
- F. For 6-inch meter installations, wall penetrations around the 6-inch DI pipe shall be sealed with 10 links of LS-410-S by PSI Thunderline/Link-Seal.
- G. 3-inch, 4-inch and 6-inch meter installations shall be equipped with a separate box to house the meter transmitter unit (MTU). The box shall be connected to the precast concrete vault with a 3/4-inch PVC conduit to allow routing of wires from the meter to the MTU. Boxes shall be:

Installation	Box Type	Lid Type
Non-Traffic Areas	Carson 1419	Carson 1419-3 with bolt-down kit
Traffic Rated Areas	Christy B1017	Christy B1017-61JH

Lids shall be permanently marked with the term "WATER." Lids marked with the term "IRRIGATION CONTROL VALVE" or similar language shall not be acceptable.

- H. Where indicated, 3-inch, 4-inch and 6-inch meter installations shall be equipped with a bypass to allow continued service to customers while meter maintenance is performed. Bypasses shall be constructed of Schedule 80 PVC pipe, made from all new rigid unplasticized polyvinyl chloride, conforming to ASTM D1785. Elbows and tees shall be of the same material as the pipe. Joint design shall be for solvent-welded construction to the pipe manufacturer's specifications. Where necessary, threaded joints shall be made with teflon tape.

2.12 METERS

- A. Meters shall be furnished and installed by the DISTRICT. The DISTRICT will install meters based on the availability of DISTRICT personnel. The CONTRACTOR shall be responsible for performing all other work required by this specification section.

2.13 INSULATING BLANKETS FOR PRECAST CONCRETE METER BOXES

- A. Precast concrete meter boxes shall be furnished with insulation blankets to protect meters and piping from freezing. Insulating blankets shall have a minimum insulation thickness of 3/8" surrounded by layers of waterproof material. Insulating blankets shall have a minimum R value of 2.8 when tested in accordance with ASTM C518. Insulating blankets shall have minimum dimensions of 6' x 10' and shall be folded as necessary to fit within the concrete meter box. Field cutting of larger blankets to the minimum size shall be allowed, provided that field cut ends are sealed with waterproof adhesive tape. Insulating blankets shall be Model No. NRB6L by Midwest Canvas Corporation, or approved equal.
- B. Single layer insulating blankets constructed of polyethylene shall not be allowed.

2.15 PIPELINE LOCATOR WIRE

- A. Pipeline locator wire shall conform to the requirements given in Section 02565 – Ductile Iron Pipe.

2.16 PIPELINE MARKING TAPE

- A. Pipeline marking tape shall conform to the requirements given in Section 02565 – Ductile Iron Pipe.

PART 3 -- INSTALLATION

3.1 GENERAL

- A. Excavation and backfill shall conform to the requirements of Section 02200 – Earthwork.
- B. Water service piping shall be tested in accordance with Section 02643 – Water Pipeline Testing and Disinfection.

3.2 SERVICE TAPS

- A. Direct tapping of water mains shall not be permitted. Double-strap service saddles shall be used for all service connections. Service saddles shall have a bearing area of sufficient width along the axis of the pipe, so that the pipe will not be distorted when the saddle is made tight. An internal shell cutter shall be used to drill through the corporation stop to minimize shavings, retain the coupon, and reduce stress. Single fluted shell cutters or twist drills shall not be used. Cutting lubricant shall be used on the cutting and tapping edges of the tool.

3.3 HOT TAPS

- A. All hot tapping of existing mains shall be performed by the DISTRICT, as indicated in Section 02642 – Hot Tap Connections.

3.4 SERVICE LATERALS

- A. Where polyethylene tubing is used for a service lateral, the tubing shall be a continuous piece from the main to the meter box. The CONTRACTOR shall not use couplings to splice together smaller pieces of tubing as a lateral installation.

3.5 FIRE SPRINKLER LATERALS

- A. Fire sprinkler laterals 2-inch in diameter and smaller may be constructed of polyethylene tubing, copper tubing or red brass pipe. Solvent welded or push-on joint PVC piping shall not be used. All portions of the buried lateral located underneath a structure shall be constructed of materials approved by the local Building Department (Nevada County, Placer County or Town of Truckee) having jurisdiction.
- B. The customer-owned portion of the fire sprinkler lateral shall be subject to pressure testing and disinfection as described in the ***Water System Construction Standards***.

- END OF SECTION -

SECTION 02641 – WATER SERVICE CONNECTIONS

PART 1 -- GENERAL

1.1 THE REQUIREMENT

- A. The CONTRACTOR shall provide water service connections for meters 1-inch and smaller in accordance with the Development Agreement.
- B. Installations utilizing meters 1.5-inch and larger shall comply with the requirements of Section 02640 – Large Water Service Connections.

1.2 RESIDENTIAL FIRE SPRINKLERS

- A. Beginning in January 2011, the installation of fire sprinklers is required for one- and two-family residential structures. The DISTRICT's policy is that unmetered fire sprinkler lines will not be installed for one- and two-family residential properties. There shall be a single metered point of service with the meter sized to accommodate the required fire sprinkler demand per Table 1 of AWWA C700.
- B. Meter box configurations for one and two-family structures shall be:

Meter Installation	Specification Section
Single meter, 3/4" or smaller, no sprinkler demand	2.7
Double meter, 3/4" or smaller, no sprinkler demand	2.8
Three or more meters, 3/4" or smaller, no sprinkler demand	2.9
Single meter, 3/4" with sprinkler demand or 1" with or without sprinkler demand	2.10
Double meter, 3/4" with sprinkler demand or 1" with or without sprinkler demand	2.10
Three or more meters, 3/4" or 1" with sprinkler demand	2.10

- C. The meter boxes configurations given in Articles 2.7, 2.8 and 2.9 shall not be used at locations where the DISTRICT will be supplying the required sprinkler demand through the meter.

1.3 REFERENCE SPECIFICATIONS, CODES, AND STANDARDS

ANSI B1.20	National Pipe Tapered (NPT) standard for Tapered Threads
ANSI B16.15	Cast Bronze Threaded Fittings
ASTM A536	Ductile Iron Castings
AWWA C700	Cold Water Meters – Displacement Type, Bronze Main Case
AWWA C800	Underground Service Line Valves and Fittings
AWWA C901	Polyethylene (PE) Pressure Pipe and Tubing, 1/2" In. (13 mm) through 3 In. (76 mm) for Water Service
Section 116875	California Health and Safety Code (Lead Free Brass)

PART 2 -- PRODUCTS

2.1 SERVICE SADDLES

- A. Service saddles shall have ductile iron bodies conforming to ASTM A536 suitable for a working pressure of 300 psi. Saddles shall be double-strap and straps shall have a minimum width of 1.5 inches. All hardware, including straps, studs, nuts and washers shall be Type 304 stainless steel. Saddles shall be **Smith-Blair Model 317**, **Romac Model 202N**, or approved equal.
- B. For PVC pipe, saddles shall be sized such that the upper end of the OD range is equal to the outside diameter of the pipe. Acceptable part numbers are:

Pipe Size	1.5" Outlet Saddle	2" Outlet Saddle
4" PVC	Romac 202N - 4.80 x 1.5" IP or Smith Blair 317-048012-000	Romac 202N - 4.80 x 2" IP or Smith Blair 317-048014-000
6" PVC	Romac 202N – 6.90 x 1.5" IP or Smith Blair 317-069012-000	Romac 202N – 6.90 x 2" IP or Smith Blair 317-069014-000
8" PVC	Romac 202N – 9.05 x 1.5" IP or Smith Blair 317-090512-000	Romac 202N – 9.05 x 2" IP or Smith Blair 317-090514-000
10" PVC	Romac 202N – 11.10 x 1.5" IP or Smith Blair 317-111012-000	Romac 202N – 11.10 x 2" IP or Smith Blair 317-111014-000
12" PVC	Romac 202N – 13.20 x 1.5" IP or Smith Blair 317-132012-000	Romac 202N – 13.20 x 2" IP or Smith Blair 317-132014-000

2.2 POLYETHYLENE TUBING

- A. Polyethylene tubing for water service lines shall meet the requirements of AWWA C901 and be made from compounds having standard code designation PE 3408.
- B. The tubing shall be copper tube size (CTS) OD base with dimensions conforming to Table 7 of AWWA C901, Pressure Class 200 (DR9). PE tubing shall be Eagle 3408, Interstate PE3408, Performance Pipe 5100 Ultra-Line, Wesflex Gold Label 3408, or approved equal.
- C. Fittings for polyethylene tubing shall be brass compression-type fittings and shall be as shown on the Approved Drawings. Stainless steel insert stiffeners shall be used at all compression joints. Insert stiffeners shall be flared at one end and beveled at approximately 45° at the other end. Stiffeners shall be supplied by the fitting manufacturer.

2.3 THREADED FITTINGS AND NIPPLES

- A. Threaded fittings and nipples shall be in accordance with ANSI B16.15. The body shall be of an alloy conforming to AWWA C800 and shall be "lead-free" in accordance with Section 116875 of the California Health and Safety Code. Fittings shall be designed for working pressures of 250 psi. Threads shall be NPT in compliance with ANSI B1.20. Threaded joints shall be made up with teflon tape.

2.4 CURB BALL VALVES

- A. Curb ball valves shall conform to AWWA C800. The valve body shall be of an alloy conforming to AWWA C800 and shall be "lead-free" in accordance with Section 116875 of

the California Health and Safety Code. Curb ball valves shall be designed for working pressures of 250 psi. End connections shall be female iron pipe thread by female iron pipe thread. Curb ball valves shall be:

Size	Curb Ball Valves
¾-inch	Ford No. B11-333-W-NL Mueller B-20200-3-N (¾")
1-inch	Ford Model B11-444-W-NL Mueller B-20200-3-N (1")
2-inch	Ford Model B11-777-W-NL Mueller B-20200-3-N (2")

No equals or substitutes will be accepted

2.5 CORPORATION BALL VALVES

- A. Corporation ball valves shall conform to AWWA C800. The valve body shall be of an alloy conforming to AWWA C800 and shall be "lead-free" in accordance with Section 116875 of the California Health and Safety Code. Corporation ball valves shall be designed for working pressures of 250 psi. End connections shall be male iron pipe thread by compression. Stiffener inserts shall be used on the end of the polyethylene pipe at the compression end. Corporation ball valves and stiffener inserts shall be:

Size	Corporation Ball Valves	Stiffener Insert
1-inch	Ford Model FB-1100-4-Q-NL Mueller B-25028-N (1")	Ford Model Insert-52 Mueller Liner 528705
1.5-inch	Ford Model FB-1100-6-Q-NL Mueller B-25028-N (1.5")	Ford Model Insert-54-Q Mueller Liner 528706
2-inch	Ford Model FB-1100-7-Q-NL Mueller B-25028-N (2")	Ford Model Insert-55-Q Mueller Liner 528707

No equals or substitutes will be accepted

2.6 COUPLINGS

- A. Couplings shall conform to AWWA C800. The coupling body shall be of an alloy conforming to AWWA C800 and shall be "lead-free" in accordance with Section 116875 of the California Health and Safety Code. Couplings shall be designed for working pressures of 250 psi. Stiffener inserts shall be used on the end of the polyethylene pipe at the compression end.
- B. Male iron pipe x compression couplings and stiffener inserts shall be:

Size	MIP Coupling	Stiffener Insert
1-inch	Ford Model C84-44-Q-NL Mueller H-15428-N (1")	Ford Model Insert-52 Mueller Liner 528705
1.5-inch	Ford Model C84-66-Q-NL Mueller H-15428-N (1.5")	Ford Model Insert-54-Q Mueller Liner 528706
2-inch	Ford Model C84-77-Q-NL Mueller H-15428-N (2")	Ford Model Insert-55-Q Mueller Liner 528707

No equals or substitutes will be accepted

- C. Female iron pipe x compression couplings and stiffener inserts shall be:

Size	FIP Coupling	Stiffener Insert
1-inch	Ford Model C14-44-Q-NL Mueller H-15451-N (1")	Ford Model Insert-52 Mueller Liner 528705
1.5-inch	Ford Model C14-66-Q-NL Mueller H-15451-N (1.5")	Ford Model Insert-54-Q Mueller Liner 528706
2-inch	Ford Model C14-77-Q-NL Mueller H-15451-N (2")	Ford Model Insert-55-Q Mueller Liner 528707

No equals or substitutes will be accepted

2.7 SINGLE METER INSTALLATIONS WITH METERS ¾-INCH AND SMALLER WITHOUT FIRE SPRINKLERS

- A. For single meter installations with meters ¾-inch and smaller, boxes shall be designed to hold one meter and shall be equipped with 1-inch inlet and outlet tubing. Tubing shall be either polybutylene or polyethylene. Meter boxes shall be nominal 18-inch diameter and 48 inches deep. Meter boxes shall be provided with 4-inch thick insulation pads and composite lids. The internal piping shall be configured with 1-inch angle ball valves on both the inlet and discharge side of the meter. Meter box components shall be as listed below:

Item	Part Number
18-inch diameter, 48-inch deep meter box	Ford PFCBB-388-18-48A-FP-NL Mueller 203-CS-18-48-F-F-B-S-N-000060
18-inch diameter, 4-inch thick insulation pad	Ford CCID Mueller 790153
18-inch diameter composite lid	Mueller 534899 Nicor 18.75LWATH

No equals or substitutes will be accepted

- B. For single meter installations located in paved areas, areas subject to vehicular loading, or where deemed necessary by the DISTRICT, a precast concrete box rated for H-20 loading shall be provided and installed to protect the plastic meter box. Such protective boxes shall be **Christy B2436** with **Christy B2436-62JH** lids and shall be installed as indicated in the Drawings. Boxes shall have metal lids with bolting mechanisms to secure the lid and shall be furnished with bolts to secure the lid. All lids shall be permanently marked with the term "WATER." Approved equals shall be accepted.

2.8 DOUBLE METER INSTALLATIONS WITH METERS ¾-INCH AND SMALLER WITHOUT FIRE SPRINKLERS

- A. For double meter installations, there are two alternates that are acceptable to the DISTRICT. One option utilizes two of the plastic meter boxes listed in Article 2.7 and places them side-by-side. The other option uses precast concrete boxes. The CONTRACTOR may choose either option, however, the option selected by the CONTRACTOR shall be used throughout the entire scope of the Work. The CONTRACTOR shall not mix and match plastic and concrete meter boxes at the CONTRACTOR'S desire.

- B. **Plastic Meter Boxes:** Double meter installations with meters ¾-inch and smaller with plastic boxes shall utilize the meter box, insulation pad and lid indicated in Article 2.7.A of this Section. The 1-1/2" x 1" x 1" Y connector shall be Ford No. Y-44-264-Q-NL or Mueller No. H-15343-N (1" x 1-1/2"). For installations located in paved areas, areas subject to vehicular loading, or where deemed necessary by the DISTRICT, a precast concrete box rated for H-20 loading shall be provided and installed to protect the plastic meter boxes. Such protective boxes shall be **Christy B3048** with **Christy B3048-63JH lids** and shall be installed as indicated in the Drawings. Boxes shall have metal lids with bolting mechanisms to secure the lid and shall be furnished with bolts to secure the lid. All lids shall be permanently marked with the term "WATER." Approved equals shall be accepted
- C. **Precast Concrete Boxes:** Double meter installations with meters ¾-inch and smaller, with precast concrete boxes shall have lids that are permanently marked with the term "WATER" or "WATER METER." In paved areas, areas subject to vehicular loading, or where deemed necessary by the DISTRICT, boxes rated for H-20 loading shall be provided. H-20 rated boxes shall have metal lids with bolting mechanisms to secure the lid and shall be furnished with bolts to secure the lid. Meters shall be equipped with meter yokes as indicated in the Drawings. Meter boxes for double meter installations shall be:

Location	Box	Extension	Lid
Non-Traffic Areas	Christy N40 Box	Christy B40x10	DFW B40C-4-LID
Traffic Rated Areas	Christy B2436 Box	Christy B2436x12	Christy B2436-62JH

Approved equals shall be accepted

Meter yoke components shall be:

Item	Part Number
Meter yoke	Ford No. Y502 Mueller H-5020
Meter yoke expansion connection	Ford No. EC-23-NL Mueller H-14234-N (3/4")
Straight yoke valve	Ford No. B91-323W-NL Mueller B-24360-N (5/8" x 3/4" x 3/4")

Approved equals shall be accepted

2.9 MULTIPLE METER INSTALLATIONS WITH METERS ¾-INCH AND SMALLER WITHOUT FIRE SPRINKLERS

- A. For installations with three or four ¾-inch or smaller meters, boxes shall be precast concrete with lids that are permanently marked with the term "WATER" or "WATER METER." In paved areas, areas subject to vehicular loading, or where deemed necessary by the DISTRICT, boxes rated for H-20 loading shall be provided. H-20 rated boxes shall have metal lids with bolting mechanisms to secure the lid and shall be furnished with bolts to secure the lid. Meters shall be equipped with meter yokes as indicated in the Standard Details. Meter boxes for three or four meter installations shall be:

Location	Box	Extension	Lid
Non-Traffic Areas	Christy N48T Box	Christy B48x10	DFW B48C-4-LID
Traffic Rated Areas	Christy B3048 Box	Christy B3048x12	Christy B3048-63JH

Approved equals shall be accepted

Meter yoke components shall be:

Item	Part Number
Meter yoke	Ford No. Y502 Mueller H-5020
Meter yoke expansion connection	Ford No. EC-23-NL Mueller H-14234-N (3/4")
Straight yoke valve	Ford No. B91-323W-NL Mueller B-24360-N (5/8" x 3/4" x 3/4")

Approved equals shall be accepted

- B. For installations with five or more meters, boxes shall be as determined by the DISTRICT. Meters shall be equipped with meter yokes as described above.

2.10 METER INSTALLATIONS WITH 3/4-INCH WITH FIRE SPRINKLERS OR 1-INCH METERS

- A. Meter boxes shall be precast concrete with lids that are permanently marked with the term "WATER" or "WATER METER." In paved areas, areas subject to vehicular loading, or where deemed necessary by the DISTRICT, boxes rated for H-20 loading shall be provided. H-20 rated boxes shall have metal lids with bolting mechanisms to secure the lid and shall be furnished with bolts to secure the lid. Meters shall be equipped with meter yokes as indicated in the Standard Details. For single or double meter installations, meter boxes shall be:

Location	Box	Extension	Lid
Non-Traffic Areas	Christy N40T Box	Christy B40x10	DFW B40C-4-LID
Traffic Rated Areas	Christy B2436 Box	Christy B2436x12	Christy B2436-62JH

Approved equals shall be accepted

For three or four meter installations, meter boxes shall be:

Location	Box	Extension	Lid
Non-Traffic Areas	Christy N48T Box	Christy B48x10	DFW B48C-4-LID
Traffic Rated Areas	Christy B3048 Box	Christy B3048x12	Christy B3048-63JH

Approved equals shall be accepted

Meter yoke components for 3/4-inch meters shall be:

Item	Part Number
Meter yoke	Ford No. Y502 Mueller H-5020
Meter yoke expansion connection	Ford No. EC-23-NL Mueller H-14234-N (3/4")
Straight yoke valve	Ford No. B91-323W-NL Mueller B-24360-N (5/8" x 3/4" x 3/4")

Approved equals shall be accepted

Meter yoke components for 1-inch meters shall be:

Item	Part Number
Meter yoke	Ford No. Y504 Mueller H-5040
Meter yoke expansion connection	Ford No. EC-4-NL Mueller H-14234-N (1")
Straight yoke valve	Ford No. B91-444W-NL Mueller B-24360-N (1")

Approved equals shall be accepted

2.11 METER INSTALLATIONS WITH METERS 1.5-INCH AND LARGER

- A. For installations with meters 1.5-inch and larger, boxes and material requirements shall be as indicated in Section 02640 – Large Water Service Connections.

2.12 METERS

- A. Meters, meter couplings (where required) and meter adapters (where required) shall be furnished and installed by the DISTRICT. The DISTRICT will install meters based on the availability of DISTRICT personnel. The CONTRACTOR shall be responsible for performing all other work required by this specification section.

2.13 INSULATING BLANKETS FOR PRECAST CONCRETE METER BOXES

- A. Precast concrete meter boxes shall be furnished with insulation blankets to protect meters and piping from freezing. Insulating blankets shall have a minimum insulation thickness of 3/8" surrounded by layers of waterproof material. Insulating blankets shall have a minimum R value of 2.8 when tested in accordance with ASTM C518. Insulating blankets shall have minimum dimensions of 6' x 10' and shall be folded as necessary to fit within the concrete meter box. Field cutting of larger blankets to the minimum size shall be allowed, provided that field cut ends are sealed with waterproof adhesive tape. Insulating blankets shall be Model No. NRB6L by Midwest Canvas Corporation, or approved equal.
- B. Single layer insulating blankets constructed of polyethylene shall not be allowed.

2.14 PIPELINE LOCATOR WIRE

- A. Pipeline locator wire shall conform to the requirements given in Section 02565 – Ductile Iron Pipe.

2.15 PIPELINE MARKING TAPE

- A. Pipeline marking tape shall conform to the requirements given in Section 02565 – Ductile Iron Pipe.

PART 3 -- INSTALLATION

3.1 GENERAL

- A. Excavation and backfill shall conform to the requirements of Section 02200 – Earthwork.
- B. Water service piping shall be tested in accordance with Section 02643 – Water Pipeline Testing and Disinfection.

3.2 SERVICE TAPS

- A. Direct tapping of water mains shall not be permitted. Double-strap service saddles shall be used for all service connections. Service saddles shall have a bearing area of sufficient width along the axis of the pipe, so that the pipe will not be distorted when the saddle is made tight. An internal shell cutter shall be used to drill through the corporation stop to minimize shavings, retain the coupon, and reduce stress. Single fluted shell cutters or twist drills shall not be used. Cutting lubricant shall be used on the cutting and tapping edges of the tool.

3.3 HOT TAPS

- A. All hot tapping of existing mains shall be performed by the DISTRICT, as indicated in Section 02642 – Hot Tap Connections.

3.4 SERVICE LATERALS

- A. All service laterals shall be a continuous piece of polyethylene tubing from the main to the meter box (or the “Y” in the case of double meter installations with plastic meter boxes). The CONTRACTOR shall not use couplings to splice together smaller pieces of tubing as a lateral installation.

3.5 ARRANGEMENT AND LABELING OF METER INSTALLATIONS

- A. For all single meter installations and double meter installations with plastic meter boxes, the CONTRACTOR shall mark the 5-digit number of the address served on the foam insulation pad using a black permanent marker. For double meter installations, boxes shall be arranged such that the box serving a given address is located closest to the centroid of that lot.
- B. For multiple meter installations (two or more) with precast concrete boxes, the DISTRICT shall furnish to the CONTRACTOR a 3-1/2” x 2” laminated card indicating the street address of each customer served. The CONTRACTOR shall be responsible to attach the laminated card to the appropriate meter using either zip-ties or rebar tie wire. The meters shall be arranged in sequential order corresponding to the arrangement of the units served by the meters. The order shall be either right-to-left or left-to-right and shall correspond to the address sequence of the given street. Irrigation meters shall be located at one end of the meter manifold. The CONTRACTOR shall take care when installing on-site piping to ensure that customer laterals are connected to the proper units. The CONTRACTOR shall not randomly connect the customer laterals to the meter manifold.

3.6 FIRE SPRINKLER LATERALS

- A. Fire sprinkler laterals 2-inch in diameter and smaller may be constructed of polyethylene tubing, copper tubing or red brass pipe. Solvent welded or push-on joint PVC piping shall not be used. All portions of the buried lateral located underneath a structure shall be constructed of materials approved by the local Building Department (Nevada County, Placer County or Town of Truckee) having jurisdiction.
- B. The customer-owned portion of the fire sprinkler lateral shall be subject to pressure testing and disinfection as described in the **Water System Construction Standards**.

3.7 METER BOX LOCATING RODS FOR CIRCULAR PLASTIC METER BOXES

- A. In order to facilitate location of plastic meter boxes during the Winter, the CONTRACTOR shall:
1. Fasten a 12-inch long piece of #4 steel reinforcing bar to the exterior of the meter box with duct tape. The top of the reinforcing bar shall be about $\frac{1}{2}$ " below finished grade.
 2. Fasten a 15-inch long piece of #4 steel reinforcing bar to the bottom of the composite meter box lid. The CONTRACTOR shall drill two $\frac{1}{4}$ " holes into ribs on the bottom of the lid and then attach the steel bar using 7-inch long zip-ties. A sample installation is shown in the photograph below. The steel bar shall be oriented exactly as shown in the photograph to allow installation of two of the DISTRICT'S meter reading radios to the bottom of the composite lid.

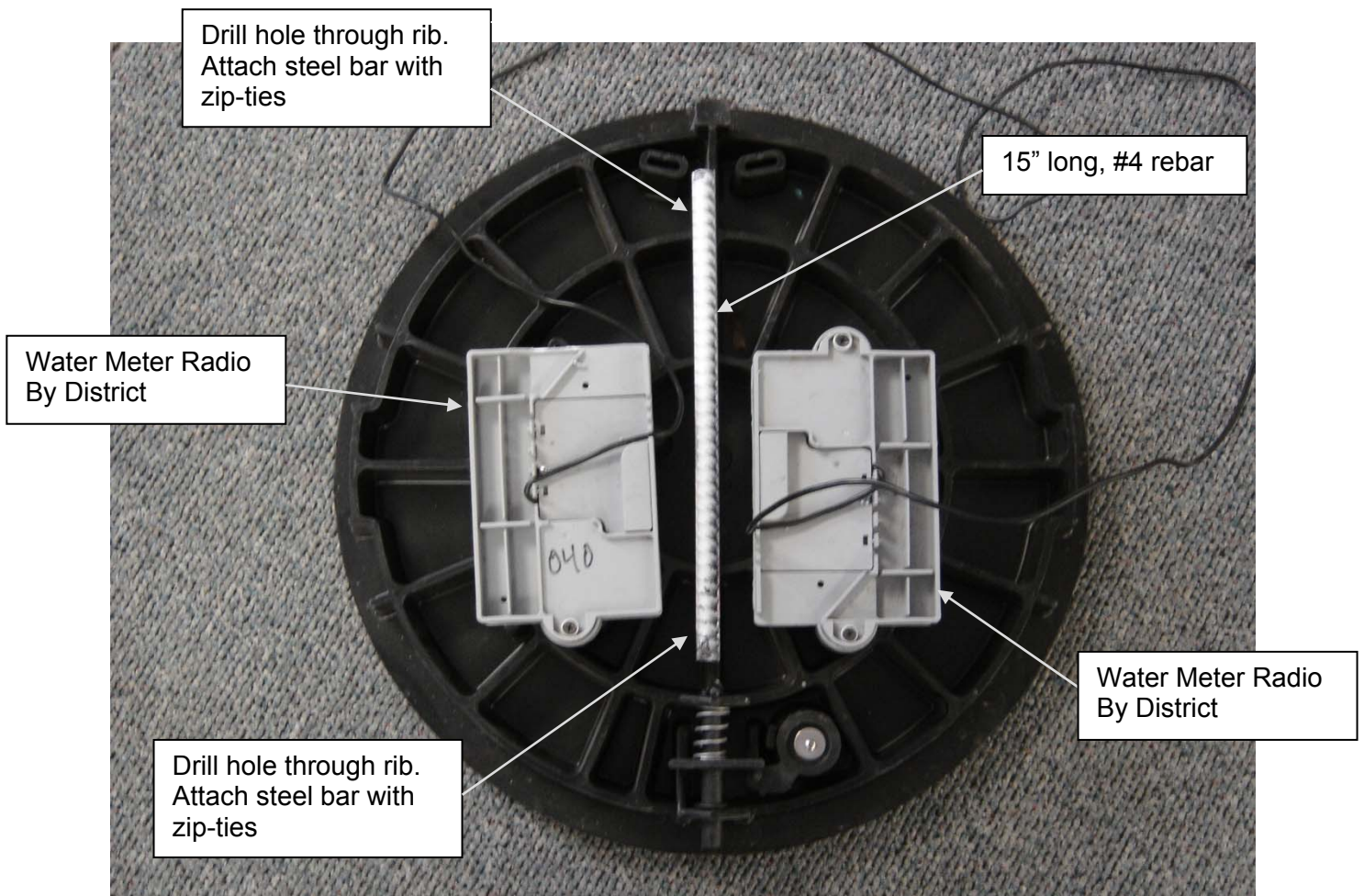

- END OF SECTION -

SECTION 02642 – HOT TAP CONNECTIONS

PART 1 -- GENERAL

1.1 THE REQUIREMENT

- A. The CONTRACTOR shall perform excavations and provide all materials necessary for hot tap connections. The DISTRICT shall perform all hot tapping of mains.
- B. Hot taps for laterals 4-inch in diameter and larger shall utilize tapping sleeves as described in Article 2.1.
- C. Hot taps for laterals 2-inch in diameter and smaller shall utilize service saddles as described in Article 2.2.

PART 2 – PRODUCTS

2.1 TAPPING SLEEVES

- A. **General:** Tapping sleeves shall be full circumferential sleeves with full circumferential gaskets suitable for a working pressure up to 200 psi. The neck shall be stainless steel welded to the body. The neck shall have a 3/4-inch test plug with NPT threads.
- B. **Body:** Tapping sleeve bodies shall be Type 304 stainless steel.
- C. **Gaskets:** Gaskets shall be virgin rubber suitable for contact with potable water.
- D. **Flanges:** Flanges shall be either Type 304 stainless steel or ductile iron. Ductile iron flanges shall be coated with fusion-bonded epoxy. Carbon steel flanges shall not be allowed.
- E. **Flange Gaskets:** Gaskets for flanged joints shall be full-faced, 1/8-inch thick synthetic rubber conforming with AWWA C115. Where provided by the manufacturer, the CONTRACTOR shall utilize the provided gasket.
- F. **Bolts and Nuts:** Bolts and nuts on tapping sleeves shall be Type 304 stainless steel. Threads on stainless steel bolts shall be coated with teflon or similar compounds to prevent galling. The nuts shall be capable of developing the full strength of the bolts. Threads shall be Coarse Thread Series conforming to the requirements of the American Standard for Screw Threads. All bolts and nuts shall have hexagon heads.
- G. **Manufacturers:** Tapping sleeves shall be Smith-Blair Models 662 or 663; Romac Model SST; or Mueller Model H-304. No equals or substitutes will be accepted.

2.2 SERVICE SADDLES

- A. Service saddles shall comply with the requirements of Section 02641 – Water Service Connections.

2.3 GATE VALVES

- A. Gate valves shall conform to the requirements of Section 15206 – Gate Valves. Gate valves shall be either FL x FL or FL x MJ.

2.4 CORPORATION STOPS

- A. Corporation stops shall comply with the requirements of Section 02641 – Water Service Connections.

2.5 THRUST AND ANCHOR BLOCKS

- A. Thrust and anchor blocks shall be constructed of portland cement concrete as specified in Section 90 of the Standard Specifications. The minimum 28-day compressive strength shall be 2,000 psi (14 MPa). Maximum aggregate size shall be 1-1/2 inch (37.5 mm) and maximum slump shall be 4 inches (10 mm). Air entrainment is not required.

2.6 UNDERCOATING

- A. Undercoating shall be NAPA Rubberized Undercoat Part Number MAC 8400, or approved equal.

PART 3 -- INSTALLATION

3.1 HOT TAP PROCEDURES

- A. The CONTRACTOR shall perform all excavation and backfill work.
- B. The CONTRACTOR shall furnish and install the tapping sleeve and gate valve on the main to be tapped.
- C. The CONTRACTOR shall contact the DISTRICT a minimum of 5 working days in advance to schedule the hot tap. The tapping sleeve and gate valve shall be installed a minimum of one day prior to the scheduled hot tap to allow DISTRICT personnel to inspect the installation in advance.
- D. Hot tapping of the main shall be performed by the DISTRICT.

3.2 UNDERCOATING

- A. CONTRACTOR shall cover all exposed areas of the existing steel pipe to remain in service with undercoating, per manufacturer's directions.

- END OF SECTION -

SECTION 02643 - WATER PIPELINE TESTING AND DISINFECTION

PART 1 -- GENERAL

1.1 THE REQUIREMENT

- A. The CONTRACTOR shall perform flushing, hydrostatic testing and disinfection of all pipelines and appurtenant piping, complete, in accordance with the Development Agreement.

1.2 REFERENCE SPECIFICATIONS, CODES, AND STANDARDS

AWWA B300 Hypochlorites

AWWA C651 Disinfecting Water Mains

1.3 CONTRACTOR SUBMITTALS

- A. The CONTRACTOR shall furnish submittals in accordance with Section 01300 – Contractor Submittals.
- B. The CONTRACTOR shall submit to the DISTRICT a written **Testing and Disinfection Plan** that addresses the proposed steps and procedures to be utilized in pressure testing, flushing and disinfecting the new pipeline installation.
 1. The Plan shall be submitted a minimum of five working days prior to the planned commencement of the procedures. The plan should discuss both the proposed source of water for testing and flushing and the proposed disposal location of water from flushing.
 2. The CONTRACTOR shall clearly describe the method of connecting the hydrostatic test pump to the piping to be pressure tested. The connection apparatus shall include a pressure gauge that is separate and independent of the hydrostatic test pump as shown in Standard Detail W-48.
 3. The plan shall comply with all appropriate regulations issued by the Town of Truckee, the Truckee Sanitary District, the Tahoe-Truckee Sanitation Agency and the Lahontan RWQCB. The CONTRACTOR shall be responsible for obtaining all necessary permits for disposal of water and copies of those permits shall be included in the **Testing and Disinfection Plan**.
 4. The DISTRICT shall review the Plan and inform the CONTRACTOR of any required changes to the proposed plan. Testing and disinfection shall not proceed and connections shall not be made to the existing water system without an approved **Testing and Disinfection Plan**.

PART 2 -- PRODUCTS

2.1 MATERIALS REQUIREMENTS

- A. All test equipment, chemicals for chlorination, temporary valves, bulkheads, or other water control equipment and materials shall be selected and furnished by the CONTRACTOR subject to the DISTRICT's review.
- B. Chlorine for disinfection may be in the form of sodium hypochlorite solution, or calcium hypochlorite granules or tablets.
- C. Sodium hypochlorite and calcium hypochlorite shall be in accordance with the requirements of AWWA B300.

PART 3 -- EXECUTION

3.1 GENERAL

- A. Disinfection shall be accomplished by chlorination. All chlorinating and testing operations shall be performed in the presence of the DISTRICT. Chlorination shall take place using either the Tablet Method or the Continuous Feed Method as outlined in AWWA C651. The Slug Method shall not be used.
- B. Disinfection operations shall be scheduled by the CONTRACTOR as late as possible during the Contract Time period so as to assure the maximum degree of sterility of the facilities at the time the WORK is accepted by the DISTRICT.

3.2 PRESSURE TESTING, FLUSHING AND DISINFECTION PROCEDURE – CONTINUOUS FEED METHOD

- A. The following procedure shall be used for pressure testing and disinfection using the Continuous Feed Method:
 - 1. The CONTRACTOR shall submit and obtain approval of the written **Testing and Disinfection Plan** described above.
 - 2. Perform and complete hydrostatic testing of the pipeline as described in Article 3.4
 - 3. After successful completion of the hydrostatic pressure test, connect the new pipeline to the DISTRICT existing system using methods to be determined at one location. There must be an isolation valve at the point of interconnection.
 - 4. Flush the new pipelines at a velocity of at least 5 fps to remove any foreign matter or debris that may have accumulated during construction.
 - 5. Introduce a hypochlorite solution into the pipeline as described in Article 3.5.
 - 6. Measure and record the chlorine residual.
 - 7. Allow a minimum 24-hour period to ensure adequate retention of the highly chlorinated water within the pipeline. Measure the chlorine residual at the end of the 24 hours. If the chlorine residual is greater than, or equal to, 40 percent of the value

recorded in Step 6, pipeline flushing may commence. If the chlorine residual is less than 40 percent of the value recorded in Step 6, introduce additional chlorine to raise the pipeline to a concentration of 25 mg/L and begin a new 24-hour retention period.

8. Flush the highly chlorinated water from the pipeline to an approved disposal location. Flushing shall continue until the chlorine residual present in the pipeline is equal to that present in the DISTRICT's system under normal operations. Measure and record the chlorine residual
9. Wait 24 hours. Take a chlorine residual sample and compare to the previous sample taken 24-hours prior. If the chlorine residual has not dropped significantly, the DISTRICT will take a water sample for bacteriological testing. Such samples may be taken from 8:00 AM to 2:00 PM on Monday through Thursday only. The sample will be delivered by the DISTRICT to the local testing laboratory. If the chlorine level has dropped significantly, the CONTRACTOR shall repeat Steps 8 & 9 until there is not a significant drop in the chlorine level.
10. Perform any remaining connections to the existing system.

3.3 PRESSURE TESTING, FLUSHING AND DISINFECTION PROCEDURE – TABLET METHOD

- A. The following procedure shall be used for pressure testing and disinfection using the Tablet Method:
 1. The CONTRACTOR shall submit and obtain approval of the written **Testing and Disinfection Plan** described above.
 2. Perform and complete hydrostatic testing of the pipeline as described in Article 3.4
 3. After successful completion of the hydrostatic pressure test, measure and record the chlorine residual. If the chlorine residual is greater than 25 mg/L, the 24-hour retention period may commence. If the chlorine residual is less than 25 mg/L, the CONTRACTOR shall introduce additional chlorine in the form of hypochlorite solution to raise the chlorine residual above 25 mg/L.
 4. Allow a minimum 24-hour period to ensure adequate retention of the highly chlorinated water within the pipeline. Measure the chlorine residual at the end of the 24 hours. If the chlorine residual is greater than, or equal to, 40 percent of the value recorded in Step 3, pipeline flushing may commence. If the chlorine residual is less than 40 percent of the value recorded in Step 3, introduce additional chlorine to raise the pipeline to a concentration of 25 mg/L and begin a new 24-hour retention period..
 5. Flush the highly chlorinated water from the pipeline to an approved disposal location. Flushing shall continue until the chlorine residual present in the pipeline is equal to that present in the DISTRICT's system under normal operations. Measure and record the chlorine residual
 6. Wait 24 hours. Take a chlorine residual sample and compare to the previous sample taken 24-hours prior. If the chlorine residual has not dropped significantly, the DISTRICT will take a water sample for bacteriological testing. Such samples may be taken from 8:00 AM to 2:00 PM on Monday through Thursday only. The sample will be delivered by the DISTRICT to the local testing laboratory. If the

chlorine level has dropped significantly, the CONTRACTOR shall repeat Steps 5 & 6 until there is not a significant drop in the chlorine level.

7. Connect the new pipeline to the existing system at one location.
8. Flush the new pipelines at a velocity of at least 5 fps to remove any foreign matter or debris that may have accumulated during construction.
9. Perform any remaining connections to the existing system.

3.4 HYDROSTATIC TESTING OF PIPELINES

- A. The CONTRACTOR shall test the entire pipeline as a single unit. The test shall be made by placing temporary bulkheads or blind flanges in the pipe and filling the line slowly with water. The CONTRACTOR shall be responsible for ascertaining that all test bulkheads or blind flanges are suitably restrained to resist the thrust of the test pressure without damage to, or movement of, the adjacent pipe. The CONTRACTOR shall provide sufficient temporary air tapplings in the pipelines to allow for evacuation of all entrapped air in each pipe segment to be tested. After completion of the tests, such taps shall be permanently plugged. Care shall be taken to see that all air vents are open during filling.
- B. The pipeline shall be filled at a rate that will not cause any surges or exceed the rate at which the air can be released through the air valves at a reasonable velocity and all the air within the pipeline shall be properly purged. During this period, bulkheads, valves, and connections shall be examined for leaks. If leaks are found, corrective measures satisfactory to the DISTRICT shall be taken.
- C. The hydrostatic test shall consist of holding the test pressure on the pipeline for a minimum period of 2 hours. The test pressure shall be as determined by the DISTRICT and shall be a minimum of 200 psi, measured at the highest point of the pipeline section being tested. All visible leaks shall be repaired in a manner acceptable to the DISTRICT.
- D. The maximum allowable leakage for distribution and transmission pipelines shall be according to the following formula:

$$L = \frac{SD\sqrt{P}}{133,200}$$

where:

L = Allowable leakage (gallons per hour)

S = length (feet), the lesser of the actual length being tested or the maximum length for determining leakage. Maximum length for determining leakage is 2000 feet.

D = nominal pipe diameter (inches)

P = test pressure (psi)

- E. Pipelines that fail to pass the prescribed leakage test will be considered defective WORK, and the CONTRACTOR shall determine the cause of the leakage, shall take corrective measures necessary to repair the leaks, and shall retest the pipelines.
- F. In the event that it is necessary to depressurize the pipeline in order to repair a leak, any disinfection procedures performed to that point shall be considered compromised. Therefore, if the CONTRACTOR was proceeding with disinfection using the Tablet Method

it will be necessary to chlorinate the pipeline after pressure testing using the continuous feed method since the highly chlorinated water would have been lost when the pipeline was depressurized.

3.5 DISINFECTING PIPELINES

- A. **Tablet Method:** Calcium hypochlorite tablets or granules shall be placed in the water main as it is being installed. The main shall then be filled with clean potable water. Calcium hypochlorite shall be placed in each section of pipe installed. The amount of calcium hypochlorite shall comply with Tables 1 and 2 of AWWA C651. The pipeline shall be filled at a rate of one foot per second or less to ensure that tablets are not washed down the pipe as it is filled. Care shall be taken to prevent the strong chlorine solution in the pipeline being disinfected from flowing back into the line supplying the water.
- B. **Continuous Feed Method:** A chlorine-water solution shall be uniformly introduced into the pipeline by means of a solution-feed chlorinating device. The chlorine solution shall be introduced at one end of the pipeline through a tap in such a manner that as the pipeline is filled with water, the concentration in the water entering the pipe is at least 25 mg/L. Appropriate backflow devices shall be used to prevent the strong chlorine solution in the pipeline being disinfected from flowing back into the line supplying the water.
- C. **Valve Operation:** During the process of chlorinating the pipelines, all line valves and other appurtenances shall be operated while the pipeline is filled with the heavily-chlorinated water.

3.6 CONNECTIONS TO EXISTING SYSTEM

- A. Where connections are to be made to an existing potable water system, the interior surfaces of all pipe and fittings used in making the connections shall be swabbed or sprayed with a one percent hypochlorite solution before they are installed. Thorough flushing shall be started as soon as the connection is completed and shall be continued until discolored water is eliminated.

3.7 WATER SOURCES

- A. As noted above, the written **Testing and Disinfection Plan** shall identify the planned water sources to be used for pressure testing and disinfection procedures. The CONTRACTOR is hereby notified that the use of non-potable water trucks as water sources is strongly discouraged. The CONTRACTOR is responsible to complete the disinfection procedures to the DISTRICT'S satisfaction. Any irregularities that arise during the course of pressure testing and disinfection procedures provide sufficient cause for the DISTRICT to require corrective measures and/or additional testing.

- END OF SECTION -

SECTION 15202 - BUTTERFLY VALVES

PART 1 -- GENERAL

1.1 THE REQUIREMENT

- A. The CONTRACTOR shall provide butterfly valves and appurtenances, complete and operable, in accordance with the Development Agreement.
- B. The CONTRACTOR is hereby notified that 12" MJ butterfly valves shall not be used with 12" PVC pipe. Due to the valve design and the wall thickness of the PVC pipe, there is inadequate clearance to allow the valve to fully open. 12" MJ butterfly valves may be used with ductile iron pipe.

1.2 REFERENCE SPECIFICATIONS, CODES, AND STANDARDS

ASTM A48	Gray Iron Castings
ASTM A126	Gray Iron Castings for Valves, Flanges, and Pipe Fittings
ASTM A307	Carbon Steel Bolts and Studs, 60,000 PSI Tensile Strength
ASTM A395	Ferritic Ductile Iron Pressure-Retaining Castings for Use at Elevated Temperatures
ASTM A536	Ductile Iron Castings
ASTM B62	Composition Bronze or Ounce Metal Castings
AWWA C115	Flanged Ductile-Iron Pipe with Threaded Flanges
AWWA C504	Rubber Seated Butterfly Valves
AWWA C550	Protective Epoxy Interior Coatings for Valves and Hydrants
AWWA C600	Installation of Ductile Iron Water Mains and Their Appurtenances

1.3 CONTRACTOR SUBMITTALS

- A. The CONTRACTOR shall furnish submittals in accordance with Section 01300 – Contractor Submittals.
- B. The CONTRACTOR shall submit the following information:
 - 1. Valve type, size, pressure rating and coating system.
 - 2. Complete information on the valve actuator, including size, type and orientation.
 - 3. Assembly drawings showing part nomenclature, materials, dimensions, weights, and relationships of valve actuators.

PART 2 -- PRODUCTS

2.1 GENERAL

- A. Butterfly valves shall conform to AWWA C504. Valves shall be of the size, end connections and working pressures indicated in the Approved Drawings.

2.2 MATERIALS

- A. **General:** Materials shall be suitable for the intended application. Materials not indicated shall be high-grade standard commercial quality, free from defects and imperfections that might affect the serviceability of the product for the purpose for which it is intended. Unless otherwise indicated, valve and actuator bodies shall conform to the following requirements:
 - 1. **Cast Iron:** Close-grained gray cast iron shall conform to ASTM A48, Class 30, or to ASTM A126.
 - 2. **Ductile Iron:** Ductile iron shall conform to ASTM A536 or ASTM A395.
 - 3. **Bronze:** Bronze shall conform to ASTM B62. Bronze shall contain not more than 5 percent of zinc or more than 2 percent of aluminum, with a minimum tensile strength of 30,000 psi, a minimum yield strength of 14,000 psi, and an elongation of at least 10 percent in 2 inches

2.3 VALVE CONSTRUCTION

- A. **Body:** The valve body shall be of cast iron or ductile iron. End connections shall be as indicated in the Drawings. Flanged valves shall be full faced. The bolt pattern of the flanges shall be compatible with the installation of flanged class 250 ductile iron fittings.
- B. **Disc:** The disc shall be of cast iron or ductile iron. The disc edge shall be Type 316 stainless steel.
- C. **Seat:** The valve seat shall be Buna N, retained in the body.
- D. **Shaft:** The shaft shall be of one-piece construction manufactured from stainless steel.
- E. **Bearings:** The shaft bearings shall be corrosion-resistant and self-lubricating, made of teflon or nylon and designed to last the life of the valve without replacement.
- F. **Packing:** The shaft packing shall be chevron-V type, fully adjustable and field-replaceable.
- G. **Actuators:** Butterfly valves shall be equipped with traveling-nut actuators, lubricated and sealed to prevent entry of dirt or water into the housing.
- H. **Flange Gaskets:** Gaskets for flanged joints shall be full-faced, 1/8-inch thick synthetic rubber conforming with AWWA C115. Gaskets shall be rated for long-term exterior above-grade installation by the manufacturer.
- I. **Nuts and Bolts:** Nuts and bolts for flanged and mechanical joints shall conform to the requirements given for nuts and bolts in Section 02565 – Ductile Iron Pipe.
- J. **Factory Testing:** Butterfly valves shall be factory tested by the manufacturer to ensure a watertight seal in both directions.

2.4 PROTECTIVE COATING

- A. The exterior surfaces and the wet interior surfaces of all butterfly valves shall be coated with polyamide-cured epoxy. High build, polyamide epoxy resin shall have a solids content of at least 56 percent by volume, and shall be suitable for long-term immersion in potable water and municipal wastewater. The coating material shall be listed by the NSF International as in compliance with NSF Standard 61 and shall comply with AWWA C550.

2.5 VALVE BOXES

- A. Valve boxes shall be precast concrete with a cast-iron lid. Valve boxes shall be cylindrical and shall have an inside diameter of 10-3/8" inches or larger. Covers of valve boxes shall be permanently labeled as "WATER". Valve boxes shall be **Christy Model G5**, or approved equal.
- B. If grade rings are required to properly install the valve box to grade, locking grade rings shall be used. Grade rings shall be manufactured by the same company as the valve box itself.
- C. Risers shall be fabricated from a single piece of SDR-35 PVC pipe with a nominal diameter of 6-inches. Riser caps shall be Model No. 304-206 by Taylor Made Plastics. No substitutes or equals will be accepted.
- D. For valves where the operating nut is more than 3.5 feet below finished grade, the CONTRACTOR shall install a valve nut extension. The length of the valve nut extension and Model Number shall be based upon Table 15202-1. Valve nut extensions shall be Placer Waterworks Model PW/VS with 5.5" ring, or approved equal.

2.6 VALVE MARKING STAKES

- A. Valve marking stakes shall be shall be "Utility Marker" model by Carsonite International. Marking stakes shall be blue in color with a white decal that reads "Water Valve" affixed to one side. Marking stakes shall be product number CRM306208. The decal shall be product number 1703 WV.

2.7 MANUFACTURERS

- A. Butterfly valves for 150 psi service shall be Mueller Lineseal III series or Pratt Groundhog Series. No equals or substitutes will be allowed.
- B. Butterfly valves for 250 psi service shall be Mueller Lineseal XP series or Pratt HP 250 series. No equals or substitutes will be allowed.

PART 3 -- EXECUTION

3.1 GENERAL

- A. Valves, actuating units, stem extensions, valve boxes, and accessories shall be installed in accordance with the Manufacturer's written instructions. Valves shall be laid in sequence with adjacent pipe and fittings.

- B. Valves shall be firmly supported on a bed of compacted Type B material to avoid undue stresses on the pipe.

3.2 VALVE BOXES

- A. All buried valves shall be furnished with a valve box and riser. The box and riser shall be centered over the valve operating nut and shall be perpendicular to the valve centerline. The box and riser shall be placed as to not transmit any shock or stress to the valve or adjacent pipe.
- B. Valve boxes shall be placed such that the cover is ½-inch below the finished grade in paved areas and 1-inch above finished grade in unpaved areas.
- C. For valve boxes located within unpaved areas, the CONTRACTOR shall install a valve marking stake adjacent to the valve box.

Table 15202-1. Valve Nut Extensions

Depth to Nut from Finish Grade	Length of Valve Extension	Placer Water Works Model #
42	18	PW / VE / 18" with 5.5" ring
43	18	PW / VE / 18" with 5.5" ring
44	18	PW / VE / 18" with 5.5" ring
45	18	PW / VE / 18" with 5.5" ring
46	24	PW / VE / 24" with 5.5" ring
47	24	PW / VE / 24" with 5.5" ring
48	24	PW / VE / 24" with 5.5" ring
49	24	PW / VE / 24" with 5.5" ring
50	24	PW / VE / 24" with 5.5" ring
51	24	PW / VE / 24" with 5.5" ring
52	24	PW / VE / 24" with 5.5" ring
53	24	PW / VE / 24" with 5.5" ring
54	24	PW / VE / 24" with 5.5" ring
55	24	PW / VE / 24" with 5.5" ring
56	24	PW / VE / 24" with 5.5" ring
57	24	PW / VE / 24" with 5.5" ring
58	36	PW / VE / 36" with 5.5" ring
59	36	PW / VE / 36" with 5.5" ring
60	36	PW / VE / 36" with 5.5" ring
61	36	PW / VE / 36" with 5.5" ring
62	36	PW / VE / 36" with 5.5" ring
63	36	PW / VE / 36" with 5.5" ring
64	36	PW / VE / 36" with 5.5" ring
65	36	PW / VE / 36" with 5.5" ring
66	36	PW / VE / 36" with 5.5" ring
67	36	PW / VE / 36" with 5.5" ring
68	36	PW / VE / 36" with 5.5" ring
69	48	PW / VE / 36" with 5.5" ring
70	48	PW / VE / 48" with 5.5" ring
71	48	PW / VE / 48" with 5.5" ring
72	48	PW / VE / 48" with 5.5" ring

- END OF SECTION -

SECTION 15206 - GATE VALVES

PART 1 -- GENERAL

1.1 THE REQUIREMENT

- A. The CONTRACTOR shall provide resilient-wedge gate valves and appurtenances, complete and operable, in accordance with the Development Agreement.

1.2 REFERENCE SPECIFICATIONS, CODES, AND STANDARDS

ASTM A48	Gray Iron Castings
ASTM A126	Gray Iron Castings for Valves, Flanges, and Pipe Fittings
ASTM A307	Carbon Steel Bolts and Studs, 60,000 PSI Tensile Strength
ASTM A395	Ferritic Ductile Iron Pressure-Retaining Castings for Use at Elevated Temperatures
ASTM A536	Ductile Iron Castings
ASTM B62	Composition Bronze or Ounce Metal Castings
ASTM B584	Copper Alloy Sand Castings for General Applications
AWWA C509	Resilient-Seated Gate Valves for Water Supply Service
AWWA C515	Reduced-Wall, Resilient-Seated Gate Valves for Water Supply Service
AWWA C550	Protective Epoxy Interior Coatings for Valves and Hydrants
AWWA C600	Installation of Ductile Iron Water Mains and Their Appurtenances

1.3 CONTRACTOR SUBMITTALS

- A. The CONTRACTOR shall furnish submittals in accordance with Section 01300 – Contractor Submittals.
- B. The CONTRACTOR shall submit the following information:
 - 1. Valve type, size, pressure rating and actuator type.
 - 2. Assembly drawings showing part nomenclature, materials, dimensions, weights, and relationships of valve actuators.

PART 2 -- PRODUCTS

2.1 GENERAL

- A. **Construction:** Gate valves shall be of the resilient-wedge type, with an inside screw, non-rising stem conforming to either AWWA C509 or C515. The valves shall be suitable for a design working water pressure of 200 psig. The valve body, bonnet, and disc shall be of cast iron or ductile iron and the disc or body shall be rubber-coated. For valves conforming to C509, the body and bonnet wall thickness shall be equal to or greater than the minimum wall thickness as listed in Table 2 of AWWA C509. For valves conforming to C515, the body and bonnet wall thickness shall be equal to or greater than the minimum wall thickness as listed in Table 1 of AWWA C515. The stem, stem nuts, glands, and bushings shall be of bronze, with O-ring seals.
- B. **Actuators:** Gate valves shall have 2-inch square operating nuts, turning counter-clockwise to open.
- C. **Buried Valves:** Buried valves shall have concrete valve boxes as indicated in Article 2.5.A. Operating nuts shall comply with AWWA C509.

2.2 MATERIALS

- A. **General:** Materials shall be suitable for the intended application. Materials not indicated shall be high-grade standard commercial quality, free from defects and imperfections that might affect the serviceability of the product for the purpose for which it is intended. Unless otherwise indicated, valve and actuator bodies shall conform to the following requirements:
 - 1. **Cast Iron:** Close-grained gray cast iron, conforming to ASTM A48, Class 30, or to ASTM A126.
 - 2. **Ductile Iron:** Ductile conforming to ASTM A536 or to ASTM A395.
 - 3. **Bronze:** Bronze conforming to ASTM B62.

2.3 VALVE CONSTRUCTION

- A. **Bodies:** Valve bodies shall be of cast or ductile iron, with smooth interior passages. Wall thicknesses shall be uniform, in agreement with the applicable standards for each type of valve and without casting defects, pinholes, or other defects that could weaken the body. Valve ends shall be as indicated in the Drawings.
- B. **Bonnets:** Valve bonnets shall be clamped, screwed, or flanged to the body and shall be of the same material, temperature, and pressure rating as the body. The bonnets shall have provision for the stem seal with the necessary glands, packing nuts, or yokes.
- C. **Stems:** Valve stems shall be of bronze with O-ring seals.
- D. **Internal Parts:** Internal parts and valve trim shall be bronze.
- E. **Nuts and Bolts:** Nuts and bolts for flanged and mechanical joints shall conform to the requirements given for nuts and bolts in Section 02565 – Ductile Iron Pipe.

2.4 PROTECTIVE COATING

- A. The exterior surfaces and the wet interior surfaces of all gate valves shall be coated with polyamide-cured epoxy. High build, polyamide epoxy resin shall have a solids content of at least 56 percent by volume, and shall be suitable for long-term immersion in potable water and municipal wastewater. The coating material shall be listed by the NSF International as in compliance with NSF Standard 61 and AWWA C550.

2.5 VALVE BOXES

- A. Valve boxes shall be precast concrete with a cast-iron lid. Valve boxes shall be cylindrical and shall have an inside diameter of 10-3/8" inches or larger. Covers of valve boxes shall be permanently labeled as "WATER". Valve boxes shall be **Christy Model G5**, or approved equal.
- B. If grade rings are required to properly install the valve box to grade, locking grade rings shall be used. Grade rings shall be manufactured by the same company as the valve box itself.
- C. Risers shall be fabricated from a single piece of SDR-35 PVC pipe with a nominal diameter of 6-inches. Riser caps shall be Model No. 304-206 by Taylor Made Plastics. No substitutes or equals will be accepted. For all gate valves by Mueller and 10-inch and 12-inch gate valves by American Flow Control, the CONTRACTOR shall install an 8" x 6" concentric reducer on the bottom of the riser.
- D. For valves where the operating nut is more than 3.5 feet below finished grade, the CONTRACTOR shall install a valve nut extension. The length of the valve nut extension and Model Number shall be based upon Table 15206-1. Valve nut extensions shall be Placer Waterworks Model PW/VS with 5.5" ring, or approved equal.

2.6 VALVE MARKING STAKES

- A. Valve marking stakes shall be shall be "Utility Marker" model by Carsonite International. Marking stakes shall be blue in color with a white decal that reads "Water Valve" affixed to one side. Marking stakes shall be product number CRM306208. The decal shall be product number 1703 WW.

2.7 MANUFACTURERS

- A. Gate valves shall be Mueller 2360 Series, Mueller 2361 Series, or American Flow Control 2500 series. No equals or substitutes will be allowed.

PART 3 -- EXECUTION

3.1 GENERAL

- A. Valves, actuating units, stem extensions, valve boxes, and accessories shall be installed in accordance with the Manufacturer's written instructions, AWWA C600 and these specifications. Valves shall be laid in sequence with adjacent pipe and fittings.
- B. Valves shall be firmly supported on a bed of compacted Type B material to avoid undue stresses on the pipe. Concrete shall not be placed around bells, flanges, couplings, nuts or bolts.

- C. Post indicators shall not be installed on valves owned by the DISTRICT. At locations where a post-indicator valve is required, the property owner shall install a second valve (owned by the property owner) with the post-indicator downstream of the DISTRICT-owned valve.

3.2 VALVE BOXES

- A. All buried valves shall be furnished with a valve box. The box and extensions shall be centered over the valve operating nut and shall be perpendicular to the valve centerline. The box and extensions shall be placed as to not transmit any shock or stress to the valve or adjacent pipe.
- B. Valve boxes shall be placed such that the cover is ½-inch below the finished grade in paved areas and 1-inch above finished grade in unpaved areas.
- C. For valve boxes located within unpaved areas, the CONTRACTOR shall install a valve marking stake adjacent to the valve box.

Table 15206-1. Valve Nut Extensions

Depth to Nut from Finish Grade	Length of Valve Extension	Placer Water Works Model #
42	18	PW / VE / 18" with 5.5" ring
43	18	PW / VE / 18" with 5.5" ring
44	18	PW / VE / 18" with 5.5" ring
45	18	PW / VE / 18" with 5.5" ring
46	24	PW / VE / 24" with 5.5" ring
47	24	PW / VE / 24" with 5.5" ring
48	24	PW / VE / 24" with 5.5" ring
49	24	PW / VE / 24" with 5.5" ring
50	24	PW / VE / 24" with 5.5" ring
51	24	PW / VE / 24" with 5.5" ring
52	24	PW / VE / 24" with 5.5" ring
53	24	PW / VE / 24" with 5.5" ring
54	24	PW / VE / 24" with 5.5" ring
55	24	PW / VE / 24" with 5.5" ring
56	24	PW / VE / 24" with 5.5" ring
57	24	PW / VE / 24" with 5.5" ring
58	36	PW / VE / 36" with 5.5" ring
59	36	PW / VE / 36" with 5.5" ring
60	36	PW / VE / 36" with 5.5" ring
61	36	PW / VE / 36" with 5.5" ring
62	36	PW / VE / 36" with 5.5" ring
63	36	PW / VE / 36" with 5.5" ring
64	36	PW / VE / 36" with 5.5" ring
65	36	PW / VE / 36" with 5.5" ring
66	36	PW / VE / 36" with 5.5" ring
67	36	PW / VE / 36" with 5.5" ring
68	36	PW / VE / 36" with 5.5" ring
69	48	PW / VE / 36" with 5.5" ring
70	48	PW / VE / 48" with 5.5" ring
71	48	PW / VE / 48" with 5.5" ring
72	48	PW / VE / 48" with 5.5" ring

– END OF SECTION –

SECTION 15231 – BLOWOFF ASSEMBLIES

PART 1 -- GENERAL

1.1 THE REQUIREMENT

- A. The CONTRACTOR shall provide blowoff assemblies, complete and operable, in accordance with the Development Agreement.

1.2 REFERENCE SPECIFICATIONS, CODES, AND STANDARDS

ASTM A536 Ductile Iron Castings

ASTM D1785 Poly (Vinyl Chloride) (PVC) Plastic Pipe, Schedules 40, 80, and 120

PART 2 -- PRODUCTS

2.1 PVC PRESSURE PIPE, SOLVENT-WELDED

- A. PVC pipe shall be made from all new rigid unplasticized polyvinyl chloride and shall be Schedule 40, conforming to ASTM D1785. Elbows and tees shall be of the same material as the pipe. Joint design shall be for solvent-welded construction to the pipe manufacturer's specifications. Threaded joints shall be made with teflon tape.

2.2 POLYETHYLENE TUBING

- A. Polyethylene tubing shall conform to the requirements of Section 02641 – Water Service Connections.

2.3 GATE VALVES

- A. Gate valves shall conform to the requirements of Section 15206 – Gate Valves.

2.4 BOXES

- A. Boxes for use in non-traffic areas shall be precast concrete with nominal interior dimensions of 24" x 36". Boxes shall have metal lids with bolting mechanisms to secure the lid. Boxes shall be furnished with bolts to secure the lid. Boxes shall be Christy model B40 with N40-61J lid, or approved equal.
- B. In paved areas, areas subject to vehicular loading, or where deemed necessary by the DISTRICT, boxes rated for H-20 loading shall be provided. H-20 rated boxes shall be precast concrete with nominal dimensions of 24" x 36". Boxes shall have metal lids with bolting mechanisms to secure the lid. Boxes shall be furnished with bolts to secure the lid. Boxes shall be Christy model B2436 with B2436-62JH lid, or approved equal.
- C. All lids shall be permanently marked with the term "WATER."

2.5 SERVICE SADDLES

- A. Service saddles shall conform to the requirements of Section 02641 – Water Service Connections.

2.6 CORPORATION STOP VALVES

- A. Corporation stop valves shall conform to the requirements of Section 02641 – Water Service Connections except that the end connections shall be male iron pipe thread by male iron pipe thread.

2.7 COUPLINGS

- A. Couplings shall conform to the requirements of Section 02641 – Water Service Connections.

2.8 THREADED FITTINGS

- A. Threaded fittings shall conform to the requirements of Section 02641 – Water Service Connections.

2.9 PIPELINE LOCATOR WIRE

- A. Pipeline locator wire shall conform to the requirements given in Section 02565 – Ductile Iron Pipe.

PART 3 -- INSTALLATION

3.1 GENERAL

- A. Excavation and backfill shall conform to the requirements of Section 02200 – Earthwork.
- B. Blowoff assembly piping shall be tested in accordance with Section 02643 – Water Pipeline Testing and Disinfection.

3.2 SERVICE TAPS

- A. Direct tapping of water mains shall not be permitted. Double-strap service saddles shall be used for all service connections. Service saddles shall have a bearing area of sufficient width along the axis of the pipe, so that the pipe will not be distorted when the saddle is made tight. An internal shell cutter shall be used to drill through the corporation stop to minimize shavings, retain the coupon, and reduce stress. Single fluted shell cutters or twist drills shall not be used. Cutting lubricant shall be used on the cutting and tapping edges of the tool.

- END OF SECTION -

SECTION 15232 – AIR VALVE ASSEMBLIES

PART 1 -- GENERAL

1.1 THE REQUIREMENT

- A. The CONTRACTOR shall provide air valve assemblies, complete and operable, in accordance with the Development Agreement.

1.2 REFERENCE SPECIFICATIONS, CODES, AND STANDARDS

ASTM B43	Seamless Red Brass Pipe, Standard Sizes
ANSI B1.20	National Pipe Tapered (NPT) standard for Tapered Threads
ANSI B16.15	Cast Bronze Threaded Fittings
AWWA C800	Underground Service Line Valves

PART 2 -- PRODUCTS

2.1 COMBINATION AIR VALVES

- A. Combination air valves shall be capable of exhausting accumulated air in systems under pressure and releasing or re-admitting large quantities of air while a system is being filled or drained, respectively. Valves shall be of the size indicated, with flanged or screwed ends to match piping. Bodies shall be of high-strength cast iron. The float, seat, and all moving parts shall be constructed of Type 316 stainless steel. Seat washers and gaskets shall be of a material insuring water tightness with a minimum of maintenance. Valves shall be designed for a minimum working pressure of 20 psi and a maximum working pressure of 300 psi. Air valves shall be Crispin model UL-10 or Cla-Val model 361-CAV564.3.

2.2 RED BRASS PIPE

- A. Red brass pipe shall conform to the requirements of ASTM B43 and shall be “lead-free” in accordance with Section 116875 of the California Health and Safety Code. Red brass pipe shall have threaded ends for NPT fittings.
- B. Fittings for red brass pipe shall be Class 250 threaded cast bronze in accordance with ANSI B16.15 and shall be “lead-free” in accordance with Section 116875 of the California Health and Safety Code. Fittings shall be designed for working pressures of 250 psi. Threads shall be NPT in compliance with ANSI B1.20. Threaded joints shall be made up with teflon tape.

2.3 PVC PRESSURE PIPE, SOLVENT-WELDED

- B. PVC pipe shall be made from all new rigid unplasticized polyvinyl chloride and shall be Schedule 40, conforming to ASTM D1785. Elbows and tees shall be of the same material as the pipe. Joint design shall be for solvent-welded construction to the pipe manufacturer's specifications. Threaded joints shall be made with teflon tape.

2.4 STOP AND WASTE BALL VALVES

- A. Stop and waste ball valves shall conform to AWWA C800. The valve body shall be of an alloy conforming to AWWA C800 and shall be "lead-free" in accordance with Section 116875 of the California Health and Safety Code. Stop and waste ball valves shall be designed for working pressures of 175 psi. End connections shall be female iron pipe thread by female iron pipe thread. Stop and waste ball valves for air valve assemblies shall be Ford Model B11-666SW-QT67-NL. No equals or substitutes will be accepted.

2.5 CORPORATION STOP VALVES

- A. Corporation stop valves shall conform to the requirements of Section 02641 – Water Service Connections except that the end connections shall be male iron pipe thread by male iron pipe thread.

2.6 DUCTILE IRON PIPE

- A. Ductile iron pipe shall conform to the requirements given in Section 02565 – Ductile Iron Pipe.

2.7 GATE VALVES

- A. Gate valves shall conform to the requirements of Section 15206 – Gate Valves.

2.8 BOXES

- A. Boxes for use in non-traffic areas shall be precast concrete with nominal interior dimensions of 24" x 36". Boxes shall have metal lids with bolting mechanisms to secure the lid. Boxes shall be furnished with bolts to secure the lid. Boxes shall be Christy model B40 with N40-61J lid, or approved equal.
- B. In paved areas, areas subject to vehicular loading, or where deemed necessary by the DISTRICT, boxes rated for H-20 loading shall be provided. H-20 rated boxes shall be precast concrete with nominal interior dimensions of 24" x 36". Boxes shall have metal lids with bolting mechanisms to secure the lid. Boxes shall be furnished with bolts to secure the lid. Boxes shall be Christy model B2436 with B2436-62JH lid, or approved equal.
- C. All lids shall be permanently marked with the term "WATER."

2.9 SERVICE SADDLES

- A. Service saddles shall conform to the requirements of Section 02641 – Water Service Connections.

2.10 TAPPING SLEEVES

- A. Tapping sleeves shall conform to the requirements of Section 02642 – Hot Tap Connections.

2.11 PIPELINE LOCATOR WIRE

- A. Pipeline locator wire shall conform to the requirements given in Section 02565 – Ductile Iron Pipe.

2.12 VALVE RISERS AND VALVE BOXES

- A. Valve risers and valve boxes shall conform to the requirements of Section 15206 – Gate Valves.

PART 3 -- EXECUTION

3.1 GENERAL

- A. Excavation and backfill shall conform to the requirements of Section 02200 – Earthwork.
- B. Air valve assembly piping shall be tested in accordance with Section 02643 – Water Pipeline Testing and Disinfection.

3.2 TAPS FOR AIR VALVE ASSEMBLIES

- A. Direct tapping of water mains shall not be permitted. Double-strap service saddles or tapping sleeves shall be used for all connections, as indicated in the Approved Drawings.
- B. Service saddles and tapping sleeves shall have a bearing area of sufficient width along the axis of the pipe, so that the pipe will not be distorted when the saddle is made tight. An internal shell cutter shall be used to drill through the corporation stop to minimize shavings, retain the coupon, and reduce stress. Single fluted shell cutters or twist drills shall not be used. Cutting lubricant shall be used on the cutting and tapping edges of the tool.

3.3 AIR VALVE INSTALLATION

- A. Air valves shall be centered within the precast concrete box. The air valve location shall be such that the air valve can be removed and reinstalled without excavating and removing the precast concrete boxes.

- END OF SECTION -

SECTION 15233 – PRESSURE REDUCING STATIONS

PART 1 -- GENERAL

1.1 THE REQUIREMENT

- A. The CONTRACTOR shall provide pressure reducing stations, complete and operable, in accordance with the Development Agreement.

1.2 REFERENCE SPECIFICATIONS, CODES, AND STANDARDS

ASTM A536	Ductile Iron Castings
ASTM B43	Seamless Red Brass Pipe, Standard Sizes
ANSI B1.20	National Pipe Tapered (NPT) standard for Tapered Threads
ANSI B16.1	Cast Iron Pipe Flanges and Flanged Fittings, Class 25, 125, 250, and 800
ANSI B16.15	Cast Bronze Threaded Fittings
ANSI B16.42	Ductile Iron Pipe Flanges and Flanged Fittings.

PART 2 -- PRODUCTS

2.1 PRESSURE REDUCING VALVES

- A. **General:** Pressure reducing valves shall reduce a higher upstream pressure to a pre-set, lower, constant pressure, regardless of fluctuations in the upstream pressure. Valves shall be globe pattern with hydraulically operated, with pilot-controlled diaphragm. All necessary repairs shall be possible without removing the valves from the pipeline.
- B. **Valve Body:** Flanged valve bodies shall be of ductile iron to ASTM A536 with 150 lb. flanged ends to ANSI B16.42. Threaded valve bodies shall be of ductile iron with screwed ends rated to 400 psi. The valve cover shall be flanged and be the same material as the body.
- C. **Valve Trim:** The valve stems with position indication, springs, body seat rings, and all bolts, nuts, and washers shall be stainless steel. All external tubing shall be copper. The valve stems shall have top and bottom guides. All rubber parts shall be of Buna-N. The diaphragms shall be of nylon-reinforced Buna-N, supported firmly between body and valve cover. The valve pistons and piston liners shall be bronze.
- D. **Valve Controls:** The valve shall be provided with a complete, externally mounted control system, including speed control needle valves, strainers, check valve, isolation valves, and all necessary copper or stainless steel connecting tubing and fittings. The controls shall be capable of achieving all the flow and speed adjustment indicated.
- E. **Operating Conditions:** Pressure reducing valves shall be designed for a maximum inlet pressure of 250 psi with the outlet pressure adjustable from 30 to 300 psi.

F. Manufacturers:

1. 6-inch flanged pressure reducing valves shall be Cla-Val Model 90-01-17301C.
2. 2-inch threaded pressure reducing valves shall be Cla-Val Model 90-01-17300E.

2.2 RED BRASS PIPE

- A. Red brass pipe shall conform to the requirements of ASTM B43 and shall be “lead-free” in accordance with Section 116875 of the California Health and Safety Code. Red brass pipe shall have threaded ends for NPT fittings.
- B. Fittings for red brass pipe shall be Class 250 threaded cast bronze in accordance with ANSI B16.15 and shall be “lead-free” in accordance with Section 116875 of the California Health and Safety Code. Fittings shall be designed for working pressures of 250 psi. Threads shall be NPT in compliance with ANSI B1.20. Threaded joints shall be made up with teflon tape.
- C. Wall penetrations around the 2-inch brass shall be sealed to prevent water intrusion. The CONTRACTOR shall submit the proposed method of sealing for approval.

2.3 CURB BALL VALVES

- A. Curb ball valves shall conform to the requirements of Section 02641 – Water Service Connections.

2.4 CORPORATION STOP VALVES

- A. Corporation stop valves shall conform to the requirements of Section 02641 – Water Service Connections except that the end connections shall be male iron pipe thread by male iron pipe thread.

2.5 DUCTILE IRON PIPE

- A. Ductile iron pipe shall conform to the requirements given in Section 02565 – Ductile Iron Pipe.
- B. Pipe supports shall be Standon Model S96 or equal, with the cradle sized appropriately for the pipe flange diameter.
- C. Wall penetrations around the 6-inch DI pipe shall be sealed with 10 links of LS-410-S by PSI Thunderline/Link-Seal.
- D. Wall penetrations around the 2-inch brass pipe shall be sealed with 6 links of LS-300-S by PSI Thunderline/Link-Seal.

2.6 GATE VALVES

- A. Gate valves shall conform to the requirements of Section 15206 – Gate Valves.

2.7 VAULTS

- A. Vaults for pressure reducing stations shall be a one piece unit, constructed of precast concrete with nominal interior dimensions of 72” W x 96” L x 84” D. Reinforcing bar size

and location shall be as recommended by the manufacturer. The exterior of the vault shall be coated with coated with Sonneborn HLM500T waterproofing, or an approved equal. To the maximum extent possible, vaults shall be located outside of roadways or other areas subject to heavy vehicular loading. Vaults shall be Model 687 TMWA by Jensen Precast (or approved equal), with the following modifications:

1. The location and dimensions of wall penetrations shall be as indicated on Detail W-45.
 2. The ladder shall be as indicated in this specification section.
- B. Vaults shall be equipped with a ladder permanently mounted to the wall of the vault. Ladders shall constructed of galvanized steel and equipped with factory-mounted, lockable, handrail extensions. Ladders shall be mounted to the vault wall in accordance with the manufacturer's instructions. Ladders shall be model VL-100 by Pipeline Products, or approved equal.
- C. Vaults shall be equipped with a permanently mounted sump pump. The pump shall have be 0.3 HP, 120 VAC power, with an integrated float switch. Shutoff head shall be 17 feet minimum. The pump outlet shall be 1.5" FIP. The CONTRACTOR shall install a 1.5" PVC schedule 40 discharge pipe running from the pump outlet to a discharge location indicated by the District in the field. The discharge location shall be downslope of the vault, such that water discharged by the pump does not flow back into the vault. The discharge pipe shall be secured to the vault wall using suitable pipe straps and anchors. Sump pumps shall be model M53-0001 by Zoeller, or approved equal.
- 2.8 SERVICE SADDLES
- A. Service saddles shall conform to the requirements of Section 02641 – Water Service Connections.
- 2.9 PIPELINE LOCATOR WIRE
- A. Pipeline locator wire shall conform to the requirements given in Section 02565 – Ductile Iron Pipe.

PART 3 -- EXECUTION

3.1 GENERAL

- A. Excavation and backfill shall conform to the requirements of Section 02200 – Earthwork.
- B. Pressure reducing station piping shall be tested in accordance with Section 02643 – Water Pipeline Testing and Disinfection.

– END OF SECTION –

SECTION 15235 - FIRE HYDRANTS

PART 1 -- GENERAL

1.1 THE REQUIREMENT

- A. The CONTRACTOR shall furnish and install dry-barrel fire hydrants including all appurtenances and accessories, complete and operable, in accordance with the requirements of the Development Agreement.

1.2 REFERENCE SPECIFICATIONS, CODES, AND STANDARDS

AWWA C502 Dry-Barrel Fire Hydrants

TT-C-494B Federal Specifications for Coating Compound, Bituminous, Solvent Type Acid Resistant

PART 2 -- PRODUCTS

2.1 FIRE HYDRANTS

- A. **Construction:** Fire hydrants shall be of the dry-barrel type according to AWWA C502. Fire hydrants shall have one 4-1/2" and two 2-1/2" national standard thread hose connections. All hose connections shall be provided with ductile iron nozzle caps with metal chains. Nozzle cap nuts shall be same shape and size as operating nuts. The stem shall have a break-away coupling. The upper standpipe shall be 28" in height. The bottom base connection shall be either 6" flanged or 6" mechanical joint. The barrel shall have a "breakable" flanged connection to connect the upper and lower standpipe sections. Both standpipe sections shall be manufactured of ductile iron. Hydrant operating threads shall be lubricated with food machinery grade grease conforming to the requirements of US 21 CFR 178.3570.
- B. **Operating Nuts:** Operating nuts shall be 1-1/2" pentagons. The operating nut shall rotate counter-clockwise to open. Operating nuts shall be equipped with weathershields.
- C. **Pressure Rating:** Fire hydrants shall be tested to 500 psig and shall be suitable for a continuous working pressure of 250 psig.

2.2 COATINGS

- A. **Exterior Coating of Upper Standpipe:** The exterior surfaces of the upper standpipe shall have a three coat paint system conforming to the requirements of AWWA C502. The paint system shall consist of one primer coat and two finish coats. Color of the finished coats shall be "Hydrant Red."
- B. **Exterior Coating of Lower Standpipe:** The exterior surfaces of the lower standpipe shall have an asphaltic coating approximately 1 mil thick.
- C. **Interior Coating:** The interior surfaces of the fire hydrant shall be coating with black asphalt paint conforming to Federal Specification TT-C-494B.

2.3 MANUFACTURERS

- A. Fire hydrants shall be Waterous Pacer Model No. WB67DDP. No equals or substitutes will be accepted.

2.4 LOCATOR WIRE AND MARKING TAPE

- A. Fire hydrant laterals shall be furnished with locator wire as indicated in Section 02565 – Ductile Iron Pipe. The locator wire shall terminate in a 2” plastic riser. The riser shall be 2” schedule 40 PVC pipe and shall be furnished with a slip x FIP adapter and a 2” threaded plug.
- B. Fire hydrant laterals shall be furnished with marking tape as indicated in Section 02565 – Ductile Iron Pipe.

2.5 BARRIER POSTS

- A. Barrier posts shall be made from pieces of 6-inch diameter steel pipe. Barrier posts shall be painted **Safety Yellow** with an exterior rated water based paint.
- B. Concrete for barrier posts shall conform to the requirements given for thrust blocks in Section 02565 – Ductile Iron Pipe.

2.6 FILTER FABRIC

- A. Filter fabric shall conform to the requirements for underdrains given in Section 88-1.03 of the Standard Specifications.

2.7 FIRE HYDRANT MARKER STAKES

- A. Fire hydrant marker stakes shall be a minimum of 54” tall and fabricated from 3/8” diameter, grade 304 stainless steel.
- B. Marker stakes shall have an offset loop. The inside diameter of the loop shall be approximately 3.5” and the loop shall be intended for installation on the 2.5” outlet of the fire hydrant. A flexible clear sleeve shall be installed on the loop portion of the stake.
- C. Marker stakes shall have color banding in the following sequence: Red-Fluorescent Yellow-Red-Fluorescent Yellow.
- D. Marker stakes shall be manufactured shall by Hy-Viz, or approved equal.

PART 3 -- EXECUTION

3.1 INSTALLATION

- A. All fire hydrants shall be installed in strict accordance with the manufacturer's published recommendations, AWWA Standards, and all applicable codes.
- B. Fire hydrant laterals shall be installed as indicated in the Approved Drawings. All joints along the hydrant lateral shall be fully restrained using mechanical methods of joint restraint. Concrete thrust blocks shall not be placed behind fire hydrants.

- C. At the time of installation, the CONTRACTOR shall turn the operating nut to ensure that the fire hydrant foot valve is fully closed.
- D. Barriers posts shall be installed at locations as required by the District and based upon a field inspection of the Project, regardless of whether or not barrier posts are indicated on the Approved Drawings.
- E. All new fire hydrant installations shall be equipped with a marker stake.

3.2 FIRE HYDRANT LOCATION

- A. Where practicable, fire hydrants shall be installed a minimum distance of six feet behind the edge of pavement or two feet behind the asphalt cement dike, if an asphalt cement dike is present.

3.3 PROTECTION OF HYDRANTS DURING CONSTRUCTION

- A. Immediately after installation, a heavy duty 30 gallon garbage bag shall be placed over the fire hydrant as a protective cover during the construction period. The bottom of the bag shall be secured with duct tape to prevent the bag from being dislodged by heavy winds. The bag shall remain in place until the DISTRICT authorizes its removal.

- END OF SECTION -



POLICY REGARDING AS-BUILT DRAWINGS

TABLE OF CONTENTS

TABLE OF CONTENTS.....	1
DEVELOPER RESPONSIBILITIES	2
PROJECT DOCUMENTATION DEPOSIT	2
AS-BUILT DRAWING PROCEDURES.....	2
AS-BUILT DRAWING FORMAT	4
LAYERING CONVENTION.....	5
Land Information	5
Electric Facilities	7
Water Facilities	8
Sanitation Facilities.....	10
Drainage Facilities	10
Text	11
DATUM POLICY	11
Horizontal Datum.....	11
Vertical Datum.....	11
Accuracy	11
METADATA POLICY.....	12
DISCOVERY	12
CONTACT INFORMATION.....	13

DEVELOPER RESPONSIBILITIES

The details of the District's As-Built Drawing policy are outlined within this document. The policy makes numerous references to a party designated as the "Developer." The term "Developer" is intended to refer to the project developer or property owner who is responsible for the construction of the project and the required water, electric and/or communication system improvements.

The Developer may utilize other parties or designated agents such as contractors, architects, surveyors or engineers to perform the duties and responsibilities outlined in this Policy. However, the failure of a third party to comply with this policy and its obligations shall not relieve the Developer of his responsibilities and shall not imply or impose any obligations upon the District.

PROJECT DOCUMENTATION DEPOSIT

At the time that the Developer signs the Development Agreement, the District shall impose a Project Documentation Deposit equal to five percent (5%) of the construction cost of water and/or electric facilities to serve the project. The minimum deposit shall be \$2000. This deposit shall be held by the District and refunded to the Developer upon successful completion of the As-Built Drawings as outlined below. The Developer shall not be due any interest on monies held by the District.

AS-BUILT DRAWING PROCEDURES

During the construction of the project, the Developer shall be responsible for maintaining a set of As-Built Drawings. The basis of the As-Built Drawings shall be the Construction Drawings as reviewed and approved by the District.

1. The Developer shall maintain one set of As-Built Drawings at the Project Site. On these, all project conditions, locations, configurations, and any other changes or deviations that may vary from the information represented on the original Construction Design Drawings shall be noted; including buried or concealed construction and utility features that are revealed during the course of construction. *Special attention shall be given to recording the horizontal and vertical location of all buried utilities that differ from the locations indicated, or which were not indicated on the Construction Design Drawings.* Drawings shall also note the location of any other buried infrastructure such as landscape irrigation, onsite drainage, lighting, hydronic heating, etc., as well as any surface building obstacles such as ponds, fences, walls, rocks, etc. As-Built drawings shall be supplemented by any detailed sketches as necessary or directed to fully indicate the facilities as actually constructed.

2. These master As-Built Drawings shall be maintained up-to-date during the progress of the Project. Red ink shall be used for alterations and notes. Notes shall identify relevant changes by number and date.
3. As-Built Drawings shall be accessible to District personnel at all times during the construction period.
4. The As-Built Drawings shall be submitted to the District upon completion of the project. Failure to submit complete As-Built Drawings may result in the partial or full forfeiture of the Project Documentation Deposit.
 - A. District staff will review for completeness, accuracy, and format, of submitted As-Built Drawings. If the As-Built Drawings are found to be acceptable, the Project Documentation Deposit will be refunded to the Developer. If the As-Built Drawings are considered unacceptable, they will be returned to the Developer for correction and resubmitted.
 - B. If the corrected As-Built Drawings have not been resubmitted to the District after 60 days, the District will correct the As-Built Drawings as necessary to conform to this Policy. All costs incurred by the District to perform such work will be deducted from the Project Documentation Deposit and the remainder will be refunded to the Developer. The District may utilize either District personnel or outside contractors to complete the As-Built Drawings. The determination of which party is to perform such work shall be at the sole discretion of the District.

In the event that the Developer fails to submit As-Built drawings within 60 days of acceptance of the facilities by the District, the District will proceed with development of the As-Built Drawings. Such failure to submit As-Built Drawings shall result in the forfeiture of the entire Project Documentation Deposit, whether or not the Deposit is sufficient to complete development of the As-Built Drawings.

AS-BUILT DRAWING FORMAT

The Developer shall submit one hard copy of the As-Built Drawings. The Developer shall also submit electronic files containing the information depicted on the As-Built Drawings.

Electronic files shall conform to the following requirements:

- A. File format shall be in one of the following formats:
 - i. AutoCAD compatible (.DWG, .DXF)
- B. Files shall be submitted on portable media such as a CD-ROM, or DVD. The media containing the files shall become the property of the District, and will not be returned to the Developer. Files may be compressed in a format that is compatible with the Zip decompression software. Developer may also upload files to the Districts FTP site. Credentials shall be provided by the District at Developer's request.
- C. The Developer shall submit all files used to produce the As-Built Drawings. Drawing files may utilize external references to reduce file size. However, all such reference files shall be included in the submittal and must conform to District layering standards.
- D. Drawing layer structure shall be as given in the Layering Convention Section. The Developer may use any combination of other layer names as desired for other elements depicted in the drawings. However, the relevant infrastructure system facilities shall appear on the designated layers. If certain facilities indicated by a given layer are not included as part of the project, the corresponding drawing layers may be purged from the drawing file.

Paper submittals shall conform to the following requirements:

- A. Drawings shall be 24" x 36" or 22" x 34" and shall be printed on bond paper
- B. All plan sheets shall be to scale and the scale shall be clearly noted on the drawings.
- C. All plan sheets shall have an arrow indicating the direction North.
- D. In cases where plan and profile sheets cannot completely depict the facilities as constructed, the Developer shall utilize details, sections, elevations or other similar drawings to illustrate the facilities as constructed. Such drawings shall be to scale and the scale shall be clearly noted on the drawings.

LAYERING CONVENTION

All digital data delivered in AutoCAD format, *must* meet the following layer convention. As-built features not adhering to these conventions will result in the immediate rejection of As-built submittals.

Land Information

R-EXIST_PARCEL

All existing parcel boundaries within the vicinity of the project under development.

R-NEW_PARCEL

All new surveyed parcel boundaries within the vicinity of the project under development. Any existing features from discovery that are a) within confines of the project, and are b) incorrect based on new survey information will be recreated as a new feature on the “new” layer.

R-EXIST_RW

All existing edge of right-of-way within the vicinity of the project under development. The edge of right-of-way for both public and private roads shall be indicated.

R-NEW_RW

All new edge of right-of-way to be constructed as part of the project under development. The edge of right-of-way for both public and private roads shall be indicated. Any existing features from discovery that are a) within confines of the project, and are b) incorrect based on new survey information will be recreated as a new feature on the “new” layer.

R-EXIST_EOP

All existing edge of pavement, within the vicinity of the project under development. The edge of pavement for both public, private roads, driveways, sidewalks, and concrete pads shall be indicated.

R-NEW_EOP

All new edge of pavement to be constructed as part of the project under development. The edge of pavement for both public, private roads, driveways, sidewalks, and concrete pads shall be indicated.. Any existing features from discovery that are a) within confines of the project, and are b) incorrect based on new survey information will be recreated as a new feature on the “new” layer.

R-EXIST_BUILDING

All existing building footprints within the vicinity of the project under development that will remain after construction is completed.

R-NEW_BUILDING

All new buildings to be finished construction at the completion of the project development. If buildings will be built at a later date than that the project, and building location is not known, these building outlines will not be required. Any existing features from discovery that are a)

within confines of the project, and are b) incorrect based on new survey information will be recreated as a new feature on the “new” layer.

R-EXIST_OBSTACLE

All existing surface obstacles including fence, walls, rockery, ponds, guardrails, etc. that may hamper construction, within the vicinity of the project under development. Each should be labeled with text describing what they are.

R-NEW_OBSTACLE

All new surface obstacles including fence, walls, rockery, ponds, guardrails, etc. that may hamper construction, within the vicinity of the project under development. Each should be labeled with text describing what they are. Any existing features from discovery that are a) within confines of the project, and are b) incorrect based on new survey information will be recreated as a new feature on the “new” layer.

R-EXIST_TRAFFIC

All existing traffic signals, signal poles, control boxes, sensor loops and similar traffic control devices within the vicinity of the project under development. Existing Traffic information will not be available in the PUD discovery.

R-NEW_TRAFFIC

All new traffic signals, signal poles, control boxes, sensor loops and similar traffic control devices to be constructed as part of the project under development.

R-EXIST_LIGHTING

All existing street lighting, light poles, circuits (both underground and overhead), control boxes and similar lighting devices within the vicinity of the project under development.

R-NEW_LIGHTING

All new street lighting, light poles, circuits (both underground and overhead), control boxes and similar lighting to be constructed as part of the project under development. Any existing features from discovery that are a) within confines of the project, and are b) incorrect based on new survey information will be recreated as a new feature on the “new” layer.

R-EXIST_TOPO

All existing topographic information including contours, and spot heights that are within the vicinity of the project under development.

R-NEW_TOPO

All new topographic information including contours, and spot heights that are within the vicinity of the project under development. Under Town specifications, new topographic information should always be surveyed for the area within the vicinity of the project under development.

R-EXIST_CONTROL

All existing survey control that are used in the survey of the project under development.

R-NEW_CONTROL

All new control points created in the development of the project.

Electric Facilities

E-NEW_PRI3PH

All new underground primary 3-phase circuits to be constructed as part of the project. Any existing features from discovery that are a) within confines of the project, and are b) incorrect based on new survey information will be recreated as a new feature on the “new” layer.

E-EXIST_PRI3PH

All existing underground primary 3-phase circuits.

E-NEW_PRI1PH

All new underground primary single-phase circuits to be constructed as part of the project. Any existing features from discovery that are a) within confines of the project, and are b) incorrect based on new survey information will be recreated as a new feature on the “new” layer. For 14.4 kV projects, 2 Phase Primary may reside on this layer.

E-EXIST_PRI1PH

All existing underground primary single-phase circuit. For 14.4 kV projects, 2 Phase Primary may reside on this layer.

E-NEW_SEC

All new underground secondary distribution to be constructed as part of the project. For the purposes of As-Built Drawings only, the secondary is considered all wire from the transformer to the point of termination. The depiction of secondary may be stopped where they enter a structure. Any existing features from discovery that are a) within confines of the project, and are b) incorrect based on new survey information will be recreated as a new feature on the “new” layer.

E-EXIST_SEC

All existing underground secondary distribution.

E-NEW_VAULT

All new vaults, boxes, manholes and other similar underground structures. Different types of underground structures should be described by use of text or different block configurations. Any existing features from discovery that are a) within confines of the project, and are b) incorrect based on new survey information will be recreated as a new feature on the “new” layer.

E-EXIST_VAULT

All existing vaults, boxes, manholes and other similar underground structures.

E-NEW_SYSTEM

All new transformers, switches, risers and similar network equipment. Any existing features from discovery that are a) within confines of the project, and are b) incorrect based on new survey information will be recreated as a new feature on the “new” layer.

E-EXIST_SYSTEM

All existing transformers, switches, risers and similar structures.

Communication Facilities

C-NEW_COMM

All new underground communication conduit and cable be constructed as part of the project. Any existing features from discovery that are a) within confines of the project, and are b) incorrect based on new survey information will be recreated as a new feature on the “new” layer.

C-EXIST_COMM

All existing underground communication conduit and cable.

C-NEW_VAULT

All new vaults, boxes, manholes and other similar underground structures. Different types of underground structures should be described by use of text or different block configurations. Any existing features from discovery that are a) within confines of the project, and are b) incorrect based on new survey information will be recreated as a new feature on the “new” layer.

C-EXIST_VAULT

All existing vaults, boxes, manholes and other similar underground structures.

C-NEW_SYSTEM

All new taps, splitters, risers and similar network equipment. Any existing features from discovery that are a) within confines of the project, and are b) incorrect based on new survey information will be recreated as a new feature on the “new” layer.

C-EXIST_SYSTEM

All new taps, splitters, risers and similar network equipment.

Water Facilities

W-NEW_PIPE

All new main line water piping to be constructed as part of the project under development. Main line piping is all piping to be dedicated to the District and maintained by the District upon successful completion of testing & acceptance of the facilities by the District. Lateral Pipes will be put on a different layer. Any existing features from discovery that are a) within confines of the project, and are b) incorrect based on new survey information will be recreated as a new feature on the “new” layer.

W-EXIST_PIPE

All existing water piping within the vicinity of the project under development. Such piping may or may not be a point of connection for new piping to be constructed.

W-NEW_LATERAL

All new water laterals, service and fire hydrant, to be constructed as part of the project under development. For the purposes of As-Built Drawings only, the lateral is considered all piping from the main line pipe through the meter box to the point of termination. The depiction of laterals may be stopped where they enter a structure. Any existing features from discovery that are a) within confines of the project, and are b) incorrect based on new survey information will be recreated as a new feature on the “new” layer.

W-EXIST_LATERAL

All existing water laterals, service and fire hydrant, within the vicinity of the project under development.

W-NEW_BOX

All new water meter boxes to be constructed as part of the project under development. Any existing features from discovery that are a) within confines of the project, and are b) incorrect based on new survey information will be recreated as a new feature on the “new” layer.

W-EXIST_BOX

All existing water meter boxes within the vicinity of the project under development.

W-NEW_FH

All new fire hydrants to be constructed as part of the project under development. Any existing features from discovery that are a) within confines of the project, and are b) incorrect based on new survey information will be recreated as a new feature on the “new” layer.

W-EXIST_FH

All existing fire hydrants within the vicinity of the project under development.

W-NEW_VALVE

All new main line water valves to be constructed as part of the project under development. Valves shall also include blow-offs, air-release valves, vacuum release valves and pressure reducing valves. Different types of valves should be described by use of text or different block configurations. Any existing features from discovery that are a) within confines of the project, and are b) incorrect based on new survey information will be recreated as a new feature on the “new” layer.

W-EXIST_VALVE

All existing main line water valves within the vicinity of the project under development.

W-NEW_FITTING

All new main line fittings to be constructed as part of the project under development. Fittings shall include tees, elbows, crosses and hydrants. Different types of fittings should be described by use of text or different block configurations. Any existing features from discovery that are a) within confines of the project, and are b) incorrect based on new survey information will be recreated as a new feature on the “new” layer.

W-EXIST_FITTING

All existing main line fittings within the vicinity of the project under development.

W-NEW_OTHER

All other water system facilities not given above to be constructed as part of the project shall be located on this layer. Any existing features from discovery that are a) within confines of the project, and are b) incorrect based on new survey information will be recreated as a new feature on the “new” layer.

W-EXIST_OTHER

All other existing water system facilities not given above shall be located on this layer.

Sanitation Facilities

S-NEW_PIPE

All new sewer mains to be constructed as part of the project under development. Manholes and other appurtenances shall be depicted on separate layers as noted below.

S-EXIST_PIPE

All existing sewer mains within the vicinity of the project under development. Such mains may or may not be a point of connection for new piping to be constructed.

S-NEW_LATERAL

All new sewer laterals to be constructed as part of the project under development. The depiction of laterals may be stopped where they enter a structure.

S-EXIST_LATERAL

All existing sewer laterals within the vicinity of the project under development.

S-NEW_MH

All new sewer manholes to be constructed as part of the project under development. Other new appurtenances such as tees and wyes shall also be depicted on this layer.

S-EXIST_MH

All existing sewer manholes and appurtenances within the vicinity of the project under development.

Drainage Facilities

D-NEW_PIPE

All new storm drain piping and culverts to be constructed as part of the project under development.

D-EXIST_PIPE

All existing storm drain piping and culverts within the vicinity of the project under development. Such piping may or may not be a point of connection for new piping to be constructed.

D-NEW_APP

All new storm drain drop inlets, junction boxes, manholes, headwalls and similar appurtenances to be constructed as part of the project under development.

D-EXIST_APP

All existing storm drain drop inlets, junction boxes, manholes, headwalls and similar appurtenances within the vicinity of the project under development. Such appurtenances may or may not be a point of connection for new facilities to be constructed.

Text

The following text is required on all as-built drawings depicting the following utilities:

Land – road names, lot ID, building #,

Electric - size, material and type of all new electric system facilities including conduit, vaults, boxes, service panels and meter panels,

Communication: size, material and type of all new communication system facilities including conduit, vaults, boxes, and service panels,

Water - size, material, lining and coating of all new water system facilities,

shall be noted:

- i. On the plans.
- ii. As text, on it's corresponding CAD layer. (i.e. Pipe size and material on W-NEW_PIPE)

DATUM POLICY

Datum policy is for electronic submittals only. As-Built drawings shall be referenced to at least three points on the drawing that have noted horizontal and vertical datum information. These three points may be existing control, new control, or parcel corners. As long as the drawing has a 1:1 relationship with these three points, the remainder of the drawing can be in a project coordinate system. The District will use these three points for location and rotation of the project coordinates at a later date. Currently, the District has a network of control in the required datum, and is available upon request. Other control exists, with a NGVD 29 vertical datum, which may be used, but conversion to NGVD 88 will be required.

Horizontal Datum

The coordinate system for all as-built drawings shall be California State Plane Coordinates, NAD 83 Zone 2 in US Survey feet.

Vertical Datum

All elevations shall be referenced to the NGVD 88 datum with elevations given in US Survey feet.

Accuracy

District discovery information, with the exception of control, has an estimated accuracy of 6" to 18" for 98% of its data. Thus the district would require no greater accuracy for As-Built submittals. Control discovery information is to be survey accurate.

The District is looking for accurate enough information to a) relocated buried facilities and b) incorporate the as-built information into the District's geographic information system.

METADATA POLICY

All new land survey information (parcel meets & bounds, control, topographic information) within the submitted as-built shall be accompanied with metadata, describing the following:

Surveyor Name

Survey Company

Date Surveyed

Control Reference Used (Control ID, Type, Coordinate Datum)

Control Type (PK nail, Brass Marker, etc)

DISCOVERY

The District has compiled an extensive collection of geographic information in the Truckee, California area. This information has a high accuracy and would be extremely valuable in any discovery required by the developer before construction. In no way, however, does this information disavow the responsibilities of the developer to survey the project area, survey existing facilities the project will tap into, or have USA performed in the area.

The discovery information will be placed by the district on the "EXIST" layers described in the layer conventions, if they exist in the confines of the project area. Any existing information that survey notes to be incorrect and is within the confines of the project area is to be recreated on the "NEW" corresponding layer. All layers described in the layering convention will also be supplied in a .DWG format drawing to the developer upon request.

Current information that can be requested:

All Electric Facility Data	All Water Facility Data	PUD Broadband Facility
Parcel Boundaries	Water Boundaries	Bridges
Edge of Pavement	Right of Way	Buildings
Obstacles (Fence, Pond, etc.)	Survey Control	Topo with Metadata
Aerial Photographs	Easements	

As a note, it is still possible for any of this information to already exist within the project area, and for the PUD not have it, or know about it. In such cases, it is the responsibility of the developer to ensure that all existing information is properly recorded on displayed in the

As-built. Discovery is to only aid the developer in collecting this information quicker and cheaper.

Discovery information for Drainage and Sanitation must come from the Town and TSD respectively.

Discovery information supplied by the PUD is the sole property of the PUD and must be returned with the as-built submittal. At no time may any discovery information be given to a third party. Third parties wishing to obtain discovery information may contact the GIS Coordinator at the number below.

CONTACT INFORMATION

GIS COORDINATOR

Megan Campe
megancampe@tdpud.org
530-582-3943

WATER ENGINEER

Neil Kaufman
neilkaufman@tdpud.org
530-582-3950

ELECTRIC ENGINEER

Joe Horvath
joehorvath@tdpud.org
530-582-3969

STANDARD DETAILS

1. PRIOR TO STARTING CONSTRUCTION OF WATER SYSTEM IMPROVEMENTS, A PRE-CONSTRUCTION MEETING MUST BE ATTENDED BY THE CONTRACTOR'S ONSITE SUPERVISOR.
2. CONTRACTOR IS RESPONSIBLE TO NOTIFY DISTRICT PERSONNEL A MINIMUM OF FIVE (5) WORKING DAYS PRIOR TO THE START OF CONSTRUCTION AND/OR WORK INVOLVING DISTRICT STAFF. CALL 582-3908.
3. ALL CONSTRUCTION AND MATERIALS PER TDPUD WATER SYSTEM CONSTRUCTION STANDARDS (CURRENT REVISION).
4. THE DISTRICT MUST REVIEW ALL MATERIALS USED ON THE PROJECT. A MINIMUM OF SEVEN (7) WORKING DAYS IS NEEDED TO RESPOND TO ALL MATERIAL SUBMITTALS.
5. SUBSTITUTION OF SPECIFIED MATERIALS MUST BE APPROVED BY THE DISTRICT PRIOR TO INSTALLATION.
6. A MINIMUM VERTICAL SEPARATION OF 12" (1') MUST BE MAINTAINED BETWEEN WATER PIPELINES AND ALL OTHER FACILITIES, EXISTING AND PROPOSED.
7. DISTRICT APPROVAL MUST BE OBTAINED PRIOR TO BACKFILLING WATER SYSTEM IMPROVEMENTS. THE DISTRICT AT ITS SOLE DISCRETION, MAY REQUIRE ANY WORK NOT APPROVED FOR BACKFILLING TO BE EXPOSED FOR INSPECTION.
8. ALL THRUST BLOCKS AND RESTRAINED JOINTS MUST BE VISUALLY INSPECTED BY THE DISTRICT PRIOR TO BACKFILLING.
9. ALL HOT TAPS MUST BE PERFORMED BY DISTRICT STAFF.
10. COMPACTION TESTS MUST BE PERFORMED BY AN APPROPRIATELY LICENSED PROFESSIONAL. COMPACTION TEST RESULTS MUST BE SUBMITTED TO THE DISTRICT.

TECHNICAL SPECIFICATIONS		CONSTRUCTION NOTES FOR WATER SYSTEM IMPROVEMENTS	DRAWING # W-1.2	DATE 2-7-06
			SCALE NO SCALE	
		 TRUCKEE DONNER Public Utility District	DRAWN MC	APPROVED NK

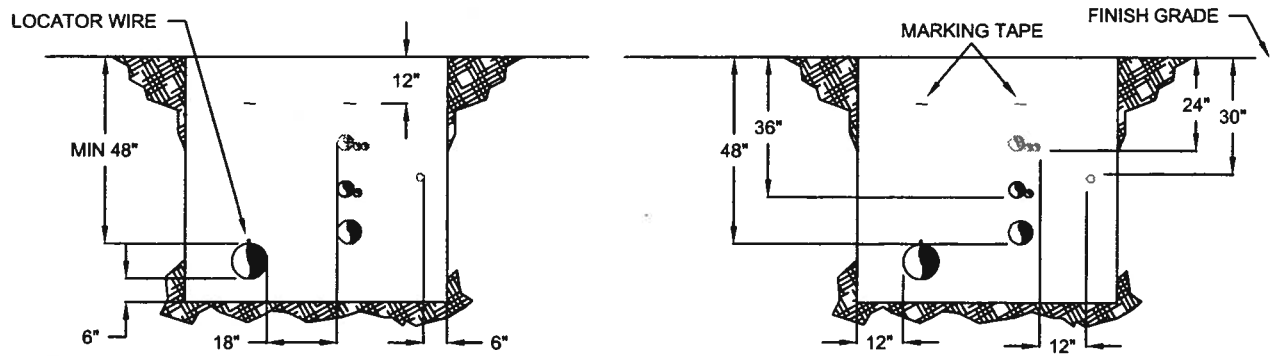

TRENCH DIMENSIONAL LAYOUT

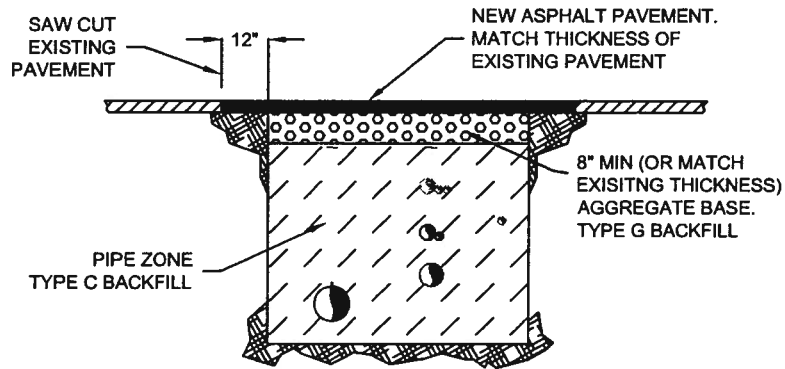

WITHIN PAVED AREAS

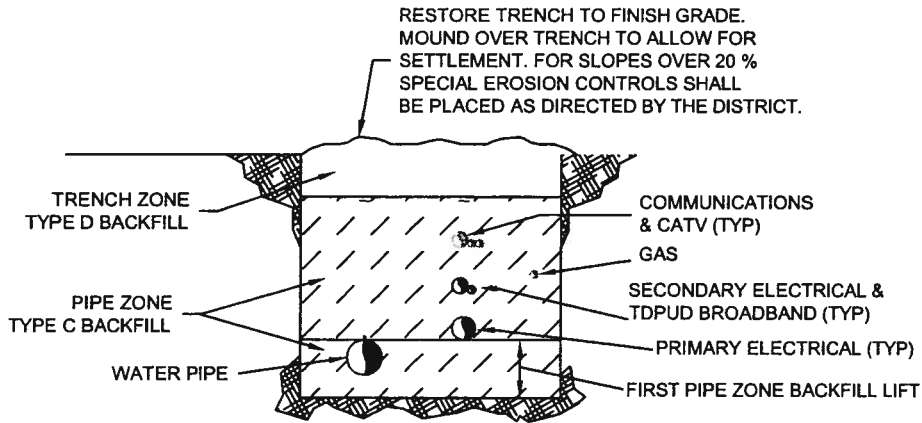

OUTSIDE PAVED AREAS

NOTES:

1. CONTACT ALL AGENCIES AND/OR UTILITIES TO CONFIRM CONSTRUCTION REQUIREMENTS.
2. THE SIDE OF THE TRENCH AT THE WATER PIPE OPPOSITE FROM THE OTHER UTILITIES MUST REMAIN FREE OF ANY OBSTRUCTIONS.
3. APPROVAL FROM DISTRICT ENGINEER IS REQUIRED FOR ANY PIPELINE INSTALLED DEEPER THAN 72" TO TOP OF PIPE.

TECHNICAL SPECIFICATIONS		JOINT TRENCH DETAIL	DRAWING #	REVISED
02200			W-2.5	3-14-07
02460		 TRUCKEE DONNER Public Utility District	SCALE	
02565			NO SCALE	
02643			DRAWN	APPROVED
			MC	NK

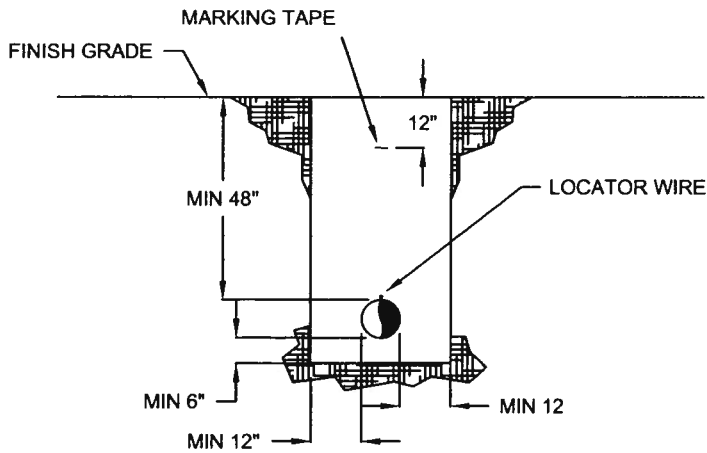

MINIMUM TRENCH WIDTH	
PIPE DIAMETER	WIDTH
4"	30"
6"	30"
8"	32"
10"	34"
12"	36"
14"	38"

TRENCH DIMENSIONAL LAYOUT

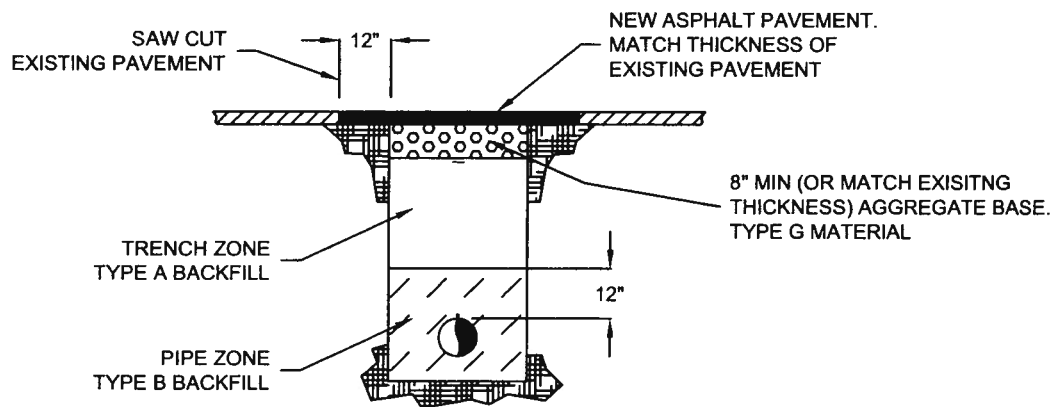

WITHIN PAVED AREAS

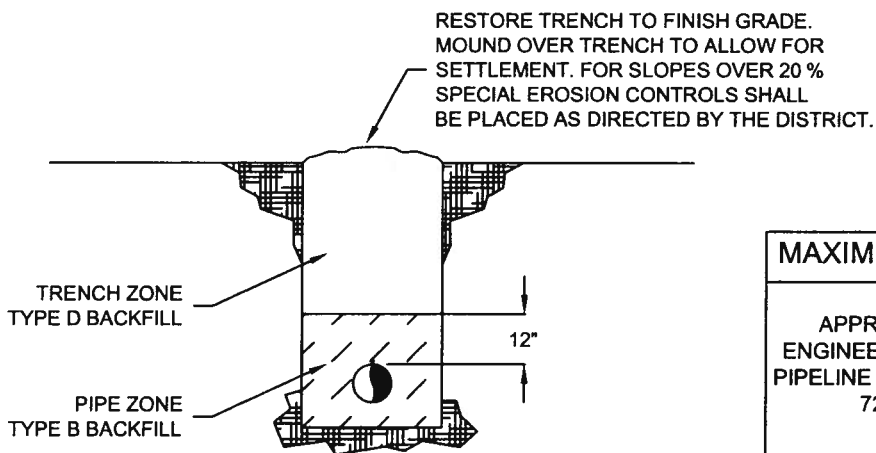

OUTSIDE PAVED ROADS

MAXIMUM TRENCH DEPTH
APPROVAL FROM DISTRICT ENGINEER IS REQUIRED FOR ANY PIPELINE INSTALLED DEEPER THAN 72" TO TOP OF PIPE

TECHNICAL SPECIFICATIONS		TRENCH DETAIL FOR PIPE 4" & LARGER	DRAWING #	REVISED
02200			 TRUCKEE DONNER Public Utility District	W-3.4
02460		SCALE		
02565		NO SCALE		
02643		DRAWN		APPROVED
			MC	NK

CONSTRUCTION NOTES:

1. TDPUD TO PERFORM ALL MAIN TAPS
2. SCHEDULE TAPS A MINIMUM 5 WORKING DAYS IN ADVANCE
3. INSTALL TAP SLEEVE AND SCHEDULE INSPECTION MINIMUM 24 HOURS BEFORE TAP
4. ON STEEL PIPELINES ALL AREAS OF EXPOSED STEEL MUST BE COATED WITH AN APPROVED MATERIAL

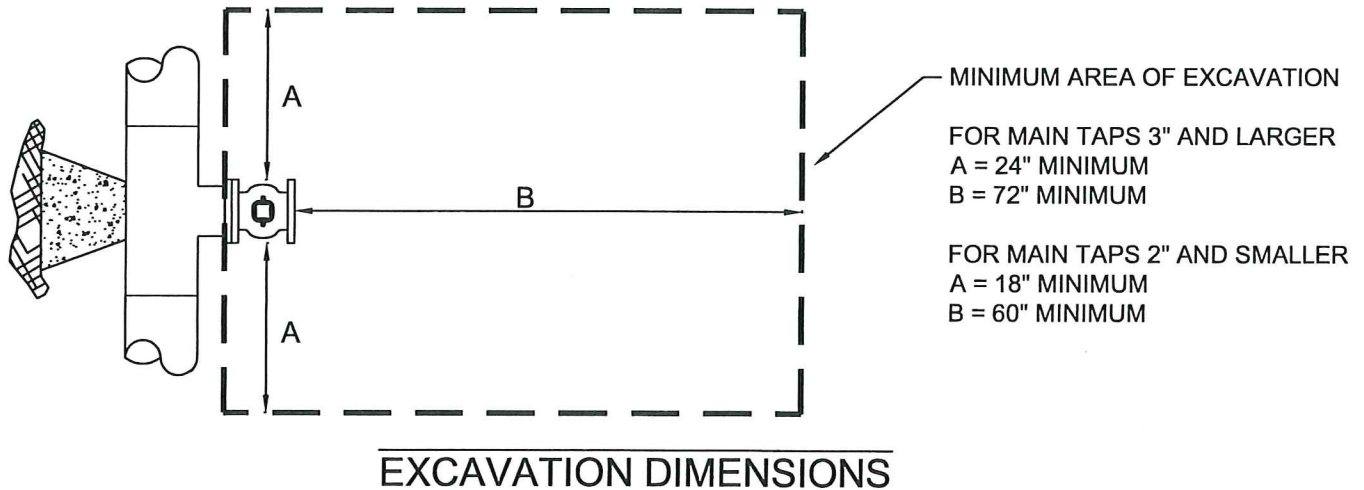
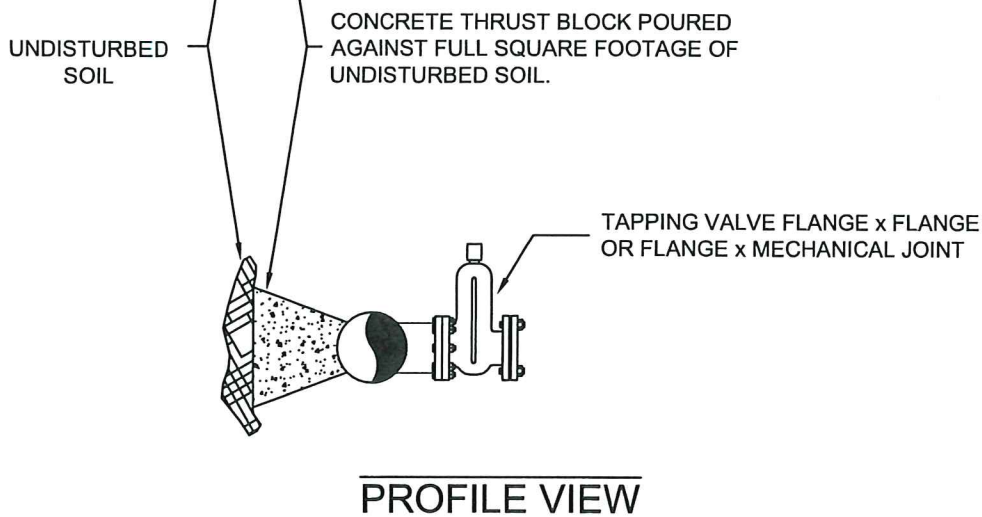
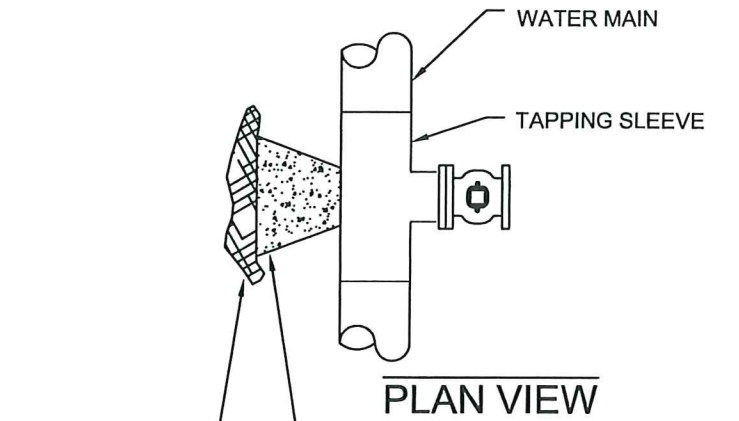

TECHNICAL SPECIFICATIONS		MAIN TAP DETAIL	DRAWING #	REVISED
02200			W-4.5	1-13-15
02565		 TRUCKEE DONNER Public Utility District	SCALE	
02642			NO SCALE	
02643			DRAWN	APPROVED
15206			MC	NK

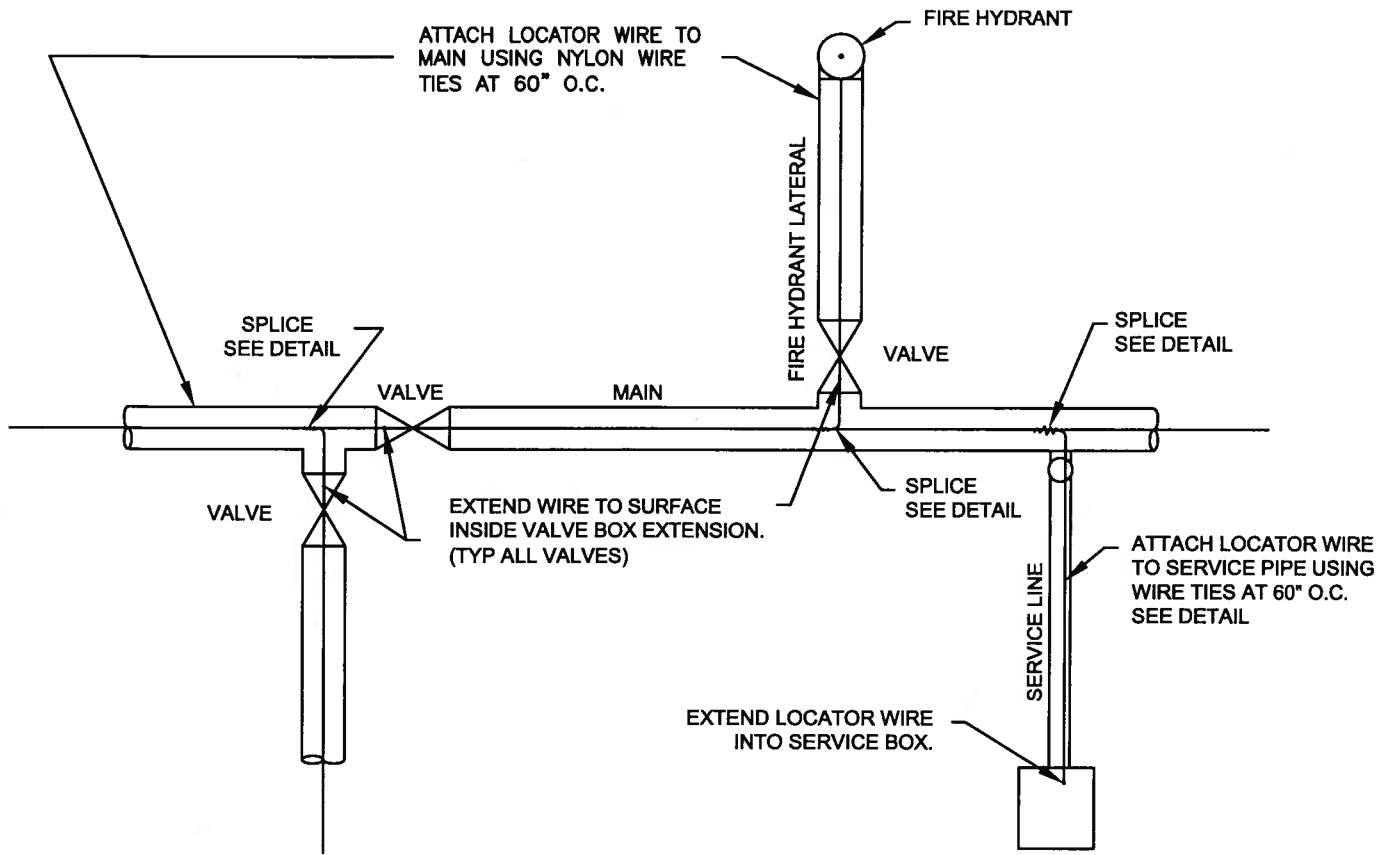

SCHMATIC PLAN

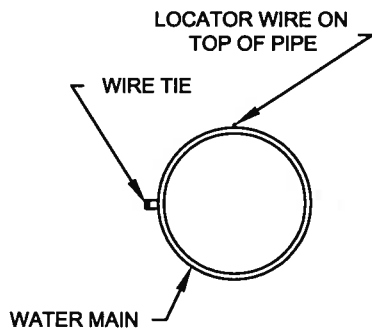

DETAIL OF WIRE ATTACHMENT

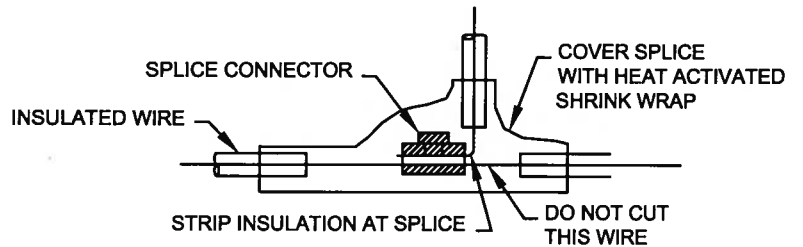

SPLICE DETAIL

TECHNICAL SPECIFICATIONS		LOCATOR WIRE DETAIL	DRAWING #	REVISED
02565			W-5.1	3-13-01
		 TRUCKEE DONNER Public Utility District	SCALE	
			NO SCALE	
			DRAWN	APPROVED
		MC	NK	

90° BEND

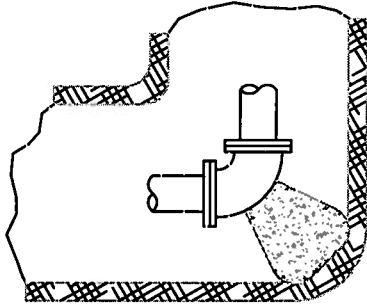

45° BEND

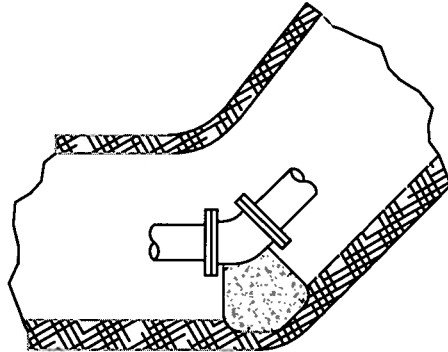

PIPE SIZE	4"	6"	8"	10 "	12"	PIPE SIZE	4"	6"	8"	10 "	12"
SQ. FEET	2	4	7	12	16	SQ. FEET	1	2	4	10	11

**22-1/2° BEND
11-1/4° BEND**

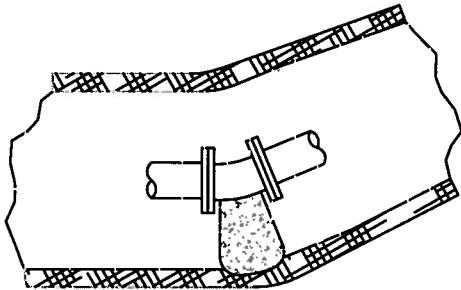

TEE OR DEAD END

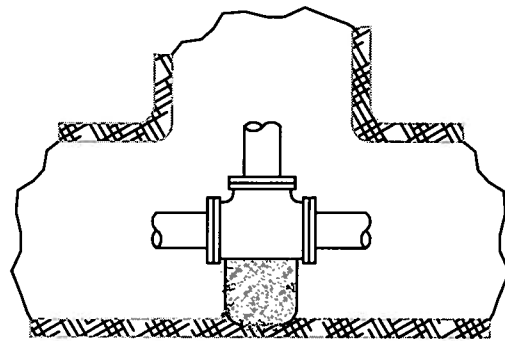

PIPE SIZE	4"	6"	8"	10 "	12"	BRANCH PIPE SIZE	4"	6"	8"	10 "	12"
SQ. FEET	1	1	2	3	5	SQ. FEET	2	3	5	8	12

- NOTES:**
- 1 AREAS GIVEN ARE FOR CLASS 350 PIPE AT TEST PRESSURE OF 150 P.S.I. IN SOIL WITH 2,000 P.S.F. BEARING CAPACITY.
 - 2 BLOCKS TO BE POURED AGAINST FULL SQUARE FOOTAGE OF UNDISTURBED SOIL AS INDICATED ON TABLE.
 - 3 ALL BOLTS AND JOINTS TO BE KEPT FREE OF CONCRETE.
 - 4 PIPE 14" DIAMETER AND LARGER TO BE RESTRAINED THROUGH USE OF APPROVED MECHANICAL DEVICES OR "FIELD-LOK" GASKETS.
 - 5 ALL THRUST BLOCKS MUST BE INSPECTED PRIOR TO BACKFILLING.
 - 6 FOR ASSEMBLIES NOT SHOWN, METHODS AND MATERIALS TO BE APPROVED PRIOR TO INSTALLATION

TECHNICAL SPECIFICATIONS		THRUST BLOCK BEARING AREAS	DRAWING # W-6.3	REVISED 2-15-04
			SCALE NO.SCALE	
		 TRUCKEE DONNER Public Utility District	DRAWN MC	APPROVED NK

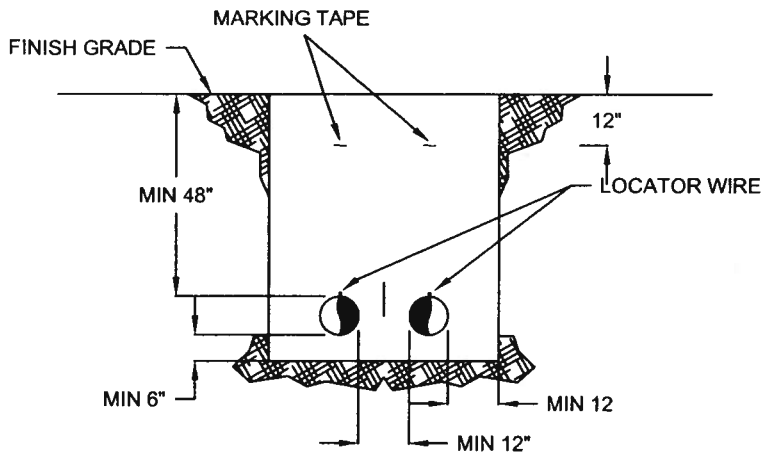

MAXIMUM TRENCH DEPTH

APPROVAL FROM DISTRICT ENGINEER
IS REQUIRED FOR ANY PIPELINE
INSTALLED DEEPER THAN 72" TO TOP
OF PIPE

TRENCH DIMENSIONAL LAYOUT

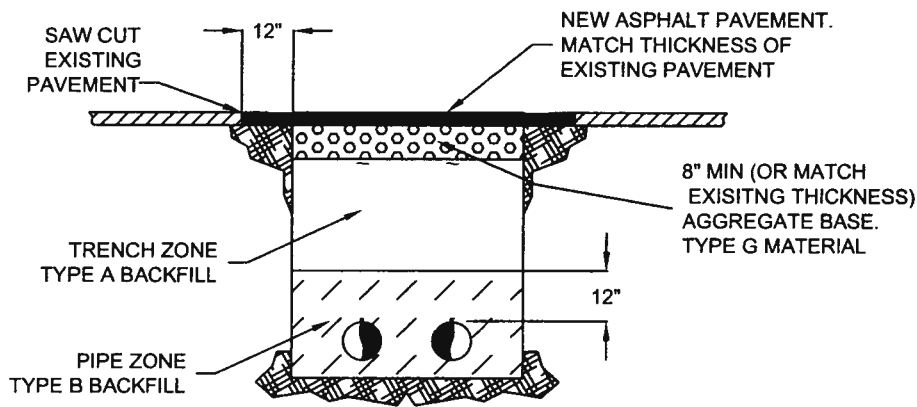

WITHIN PAVED AREAS

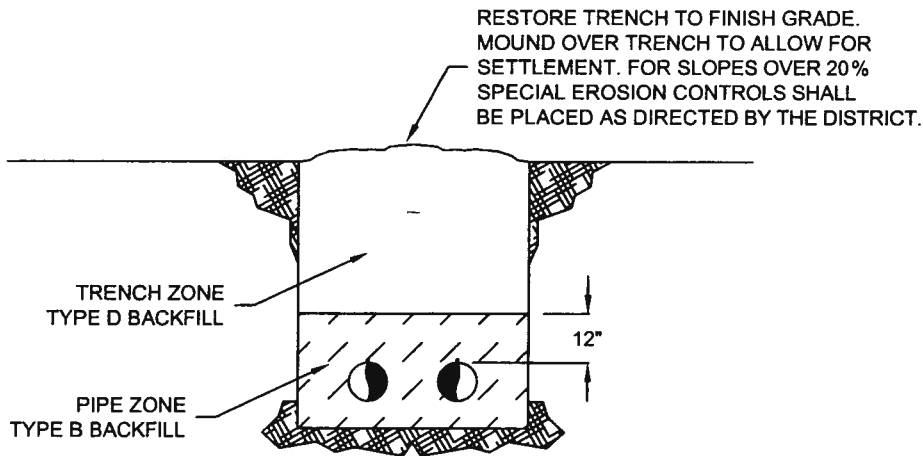

OUTSIDE PAVED ROADS

TECHNICAL SPECIFICATIONS		TRENCH DETAIL FOR PARALLEL PIPE 4" AND LARGER	DRAWING #	REVISED
02200			 TRUCKEE DONNER Public Utility District	W-7.3
02460		SCALE		
02565		NO SCALE		
02643		DRAWN		APPROVED
			MC	NK

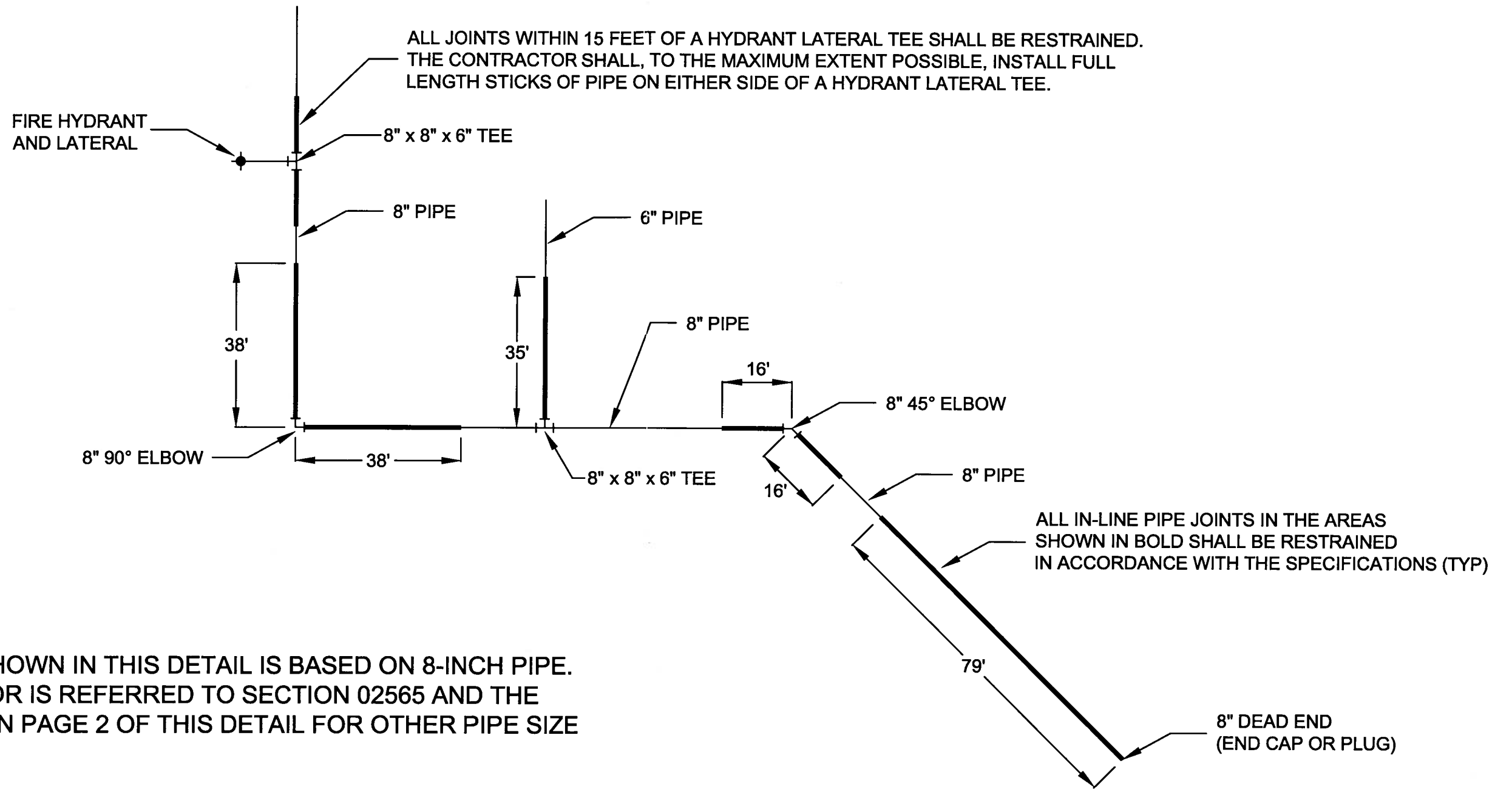

THE EXAMPLE SHOWN IN THIS DETAIL IS BASED ON 8-INCH PIPE. THE CONTRACTOR IS REFERRED TO SECTION 02565 AND THE TABLES GIVEN ON PAGE 2 OF THIS DETAIL FOR OTHER PIPE SIZE COMBINATIONS.

TECHNICAL SPECIFICATIONS		MECHANICAL PIPE RESTRAINT PAGE 1 OF 2	DRAWING #	REVISED
02565			W-8.2	2-24-04
02597		 TRUCKEE DONNER Public Utility District	SCALE	
			NO SCALE	
			DRAWN	APPROVED
			NK	NK

TEES

TEE	LENGTH	TEE	LENGTH
8" x 8" x 4"	5 FEET	16" x 16" x 10"	47 FEET
8" x 8" x 6"	35 FEET	16" x 16" x 12"	64 FEET
8" x 8" x 8"	59 FEET	16" x 16" x 14"	79 FEET
10" x 10" x 4"	0 FEET	16" x 16" x 16"	93 FEET
10" x 10" x 6"	28 FEET	20" x 20" x 4"	0 FEET
10" x 10" x 8"	54 FEET	20" x 20" x 6"	1 FOOT
10" x 10" x 10"	76 FEET	20" x 20" x 8"	25 FEET
12" x 12" x 4"	0 FEET	20" x 20" x 10"	44 FEET
12" x 12" x 6"	21 FEET	20" x 20" x 12"	61 FEET
12" x 12" x 8"	49 FEET	20" x 20" x 14"	76 FEET
12" x 12" x 10"	72 FEET	20" x 20" x 16"	91 FEET
12" x 12" x 12"	92 FEET	20" x 20" x 20"	117 FEET
14" x 14" x 4"	0 FEET	24" x 24" x 4"	0 FEET
14" x 14" x 6"	12 FEET	24" x 24" x 6"	0 FEET
14" x 14" x 8"	33 FEET	24" x 24" x 8"	18 FEET
14" x 14" x 10"	51 FEET	24" x 24" x 10"	38 FEET
14" x 14" x 12"	66 FEET	24" x 24" x 12"	56 FEET
14" x 14" x 14"	81 FEET	24" x 24" x 14"	72 FEET
16" x 16" x 4"	0 FEET	24" x 24" x 16"	87 FEET
16" x 16" x 6"	7 FEET	24" x 24" x 20"	114 FEET
16" x 16" x 8"	30 FEET	24" x 24" x 24"	139 FEET

THE TABLE ABOVE GIVES THE LENGTH OF PIPE ON THE BRANCH THAT MUST BE RESTRAINED. PIPE ON THE THROUGH RUN MAY BE UNRESTRAINED PROVIDED THAT ANOTHER NEARBY FITTING DOES NOT REQUIRE RESTRAINED PIPE.

DEAD ENDS

DEAD END	4"	6"	8"	10"	12"	14"	16"	20"	24"
END CAP	42 FEET	61 FEET	79 FEET	96 FEET	112 FEET	128 FEET	144 FEET	172 FEET	201 FEET
PLUG	42 FEET	61 FEET	79 FEET	96 FEET	112 FEET	128 FEET	144 FEET	172 FEET	201 FEET

THE TABLE ABOVE GIVES THE LENGTH OF PIPE FROM THE DEAD END THAT THE PIPE JOINTS MUST BE RESTRAINED.

ELBOWS

ELBOW	4"	6"	8"	10"	12"	14"	16"	20"	24"
11.25°	2 FEET	3 FEET	4 FEET	4 FEET	5 FEET	6 FEET	7 FEET	9 FEET	10 FEET
22.5°	4 FEET	6 FEET	7 FEET	9 FEET	11 FEET	13 FEET	14 FEET	17 FEET	20 FEET
45°	9 FEET	12 FEET	16 FEET	19 FEET	22 FEET	27 FEET	30 FEET	36 FEET	42 FEET
90°	22 FEET	29 FEET	38 FEET	46 FEET	53 FEET	64 FEET	72 FEET	86 FEET	100 FEET

THE TABLE ABOVE GIVES THE LENGTH OF PIPE ON EACH SIDE OF THE ELBOW THAT THE PIPE JOINTS MUST BE RESTRAINED.

TECHNICAL SPECIFICATIONS		MECHANICAL PIPE RESTRAINT PAGE 2 OF 2	DRAWING # W-8.2	REVISED 2-24-04
02565			SCALE NO SCALE	
02597		 TRUCKEE DONNER Public Utility District	DRAWN NK	APPROVED NK

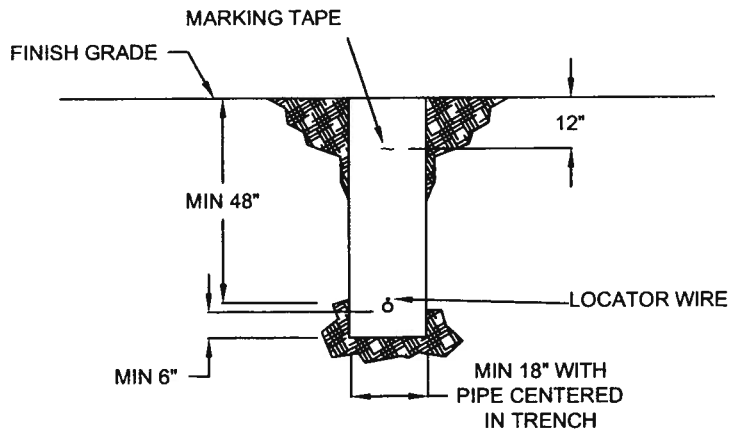

TRENCH DIMENSIONAL LAYOUT

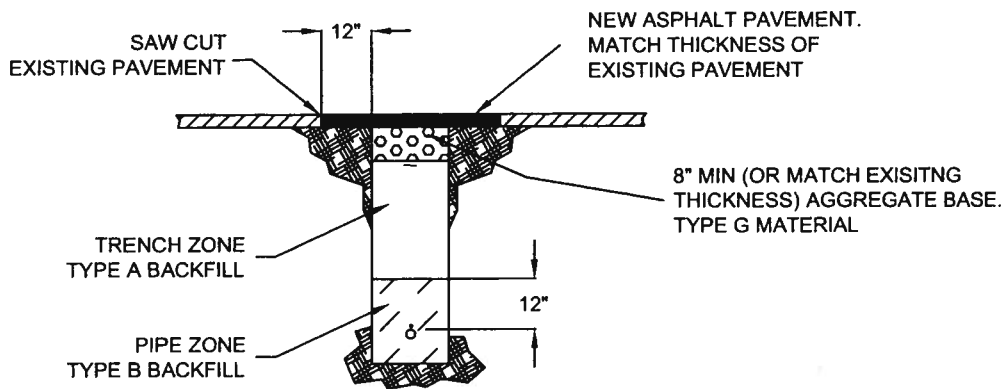

WITHIN PAVED AREAS

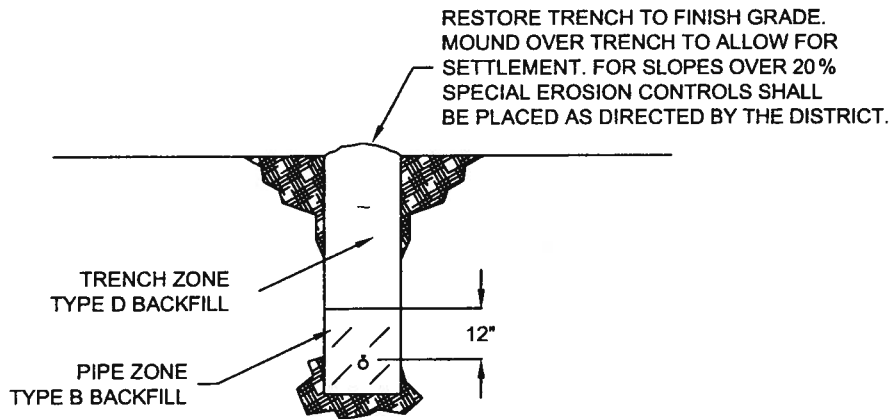

OUTSIDE PAVED ROADS

TECHNICAL SPECIFICATIONS		TRENCH DETAIL FOR POLYETHYLENE TUBING 2" & SMALLER	DRAWING # W-10.3	REVISED 12-26-07
02200			SCALE NO SCALE	
02460		 TRUCKEE DONNER Public Utility District	DRAWN MC	APPROVED NK
02641				
02643				

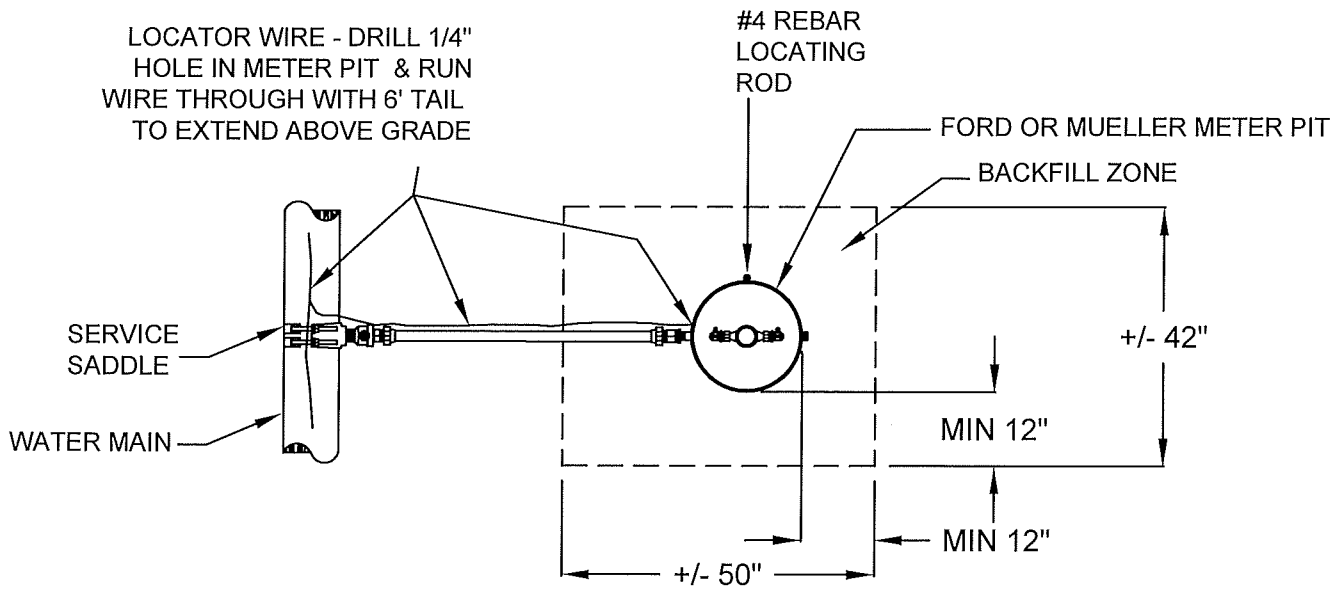

PLAN VIEW

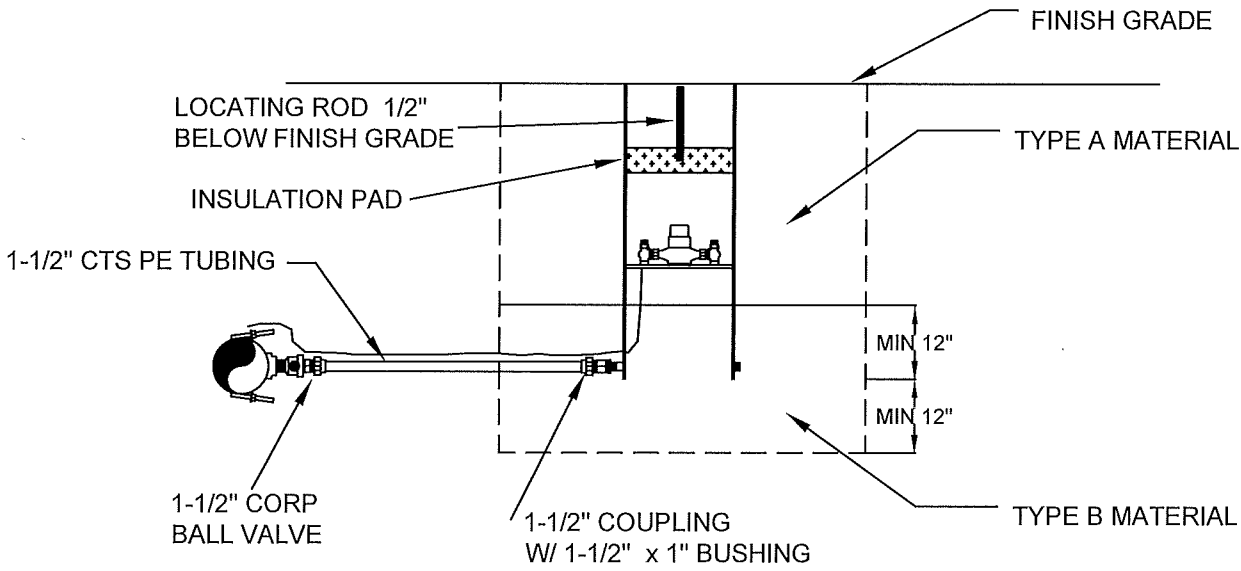

PROFILE VIEW

NOTES:

- 1) INSTALLATIONS WITHIN PAVED AREAS OR SUBJECT TO TRAFFIC LOADING REQUIRE TRAFFIC RATED BOXES. SEE DETAIL W-14.x
- 2) THIS DETAIL SHALL NOT BE USED FOR SINGLE FAMILY RESIDENTIAL SERVICES WHERE FIRE SPRINKLERS ARE REQUIRED

TECHNICAL SPECIFICATIONS		SINGLE SERVICE DETAIL	DRAWING #	REVISED
02200			W-11.7	1-9-2017
02641		 TRUCKEE DONNER Public Utility District	SCALE	
02642			NO SCALE	
02643			DRAWN	APPROVED
			NK	NK

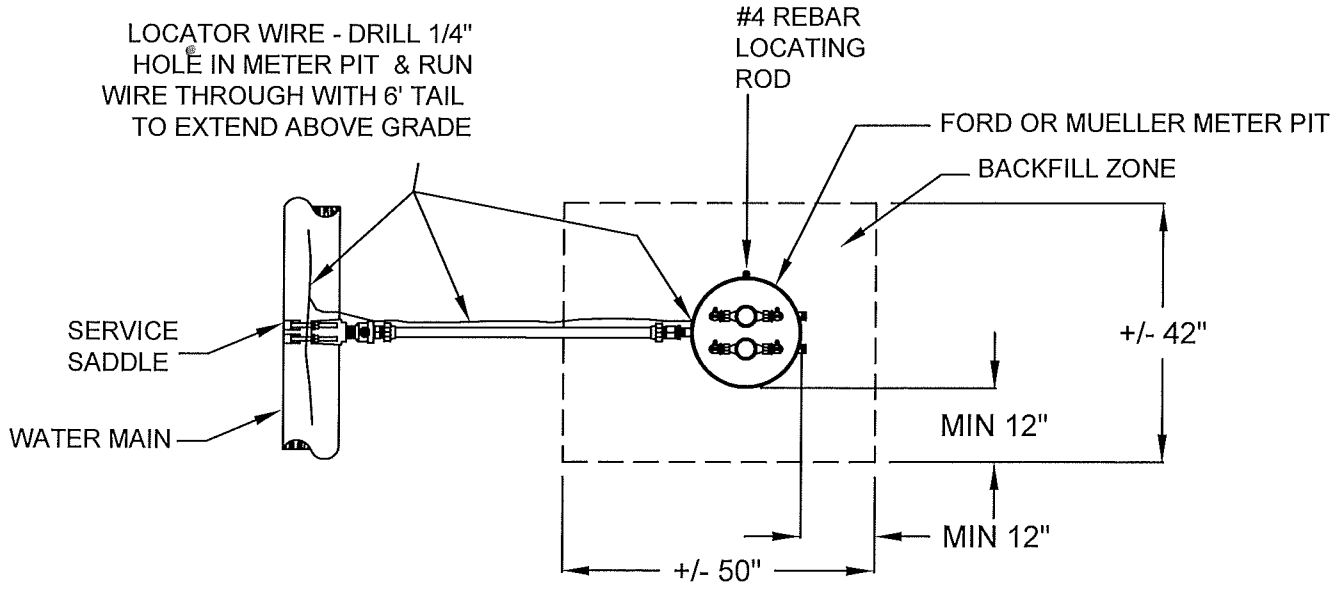

PLAN VIEW

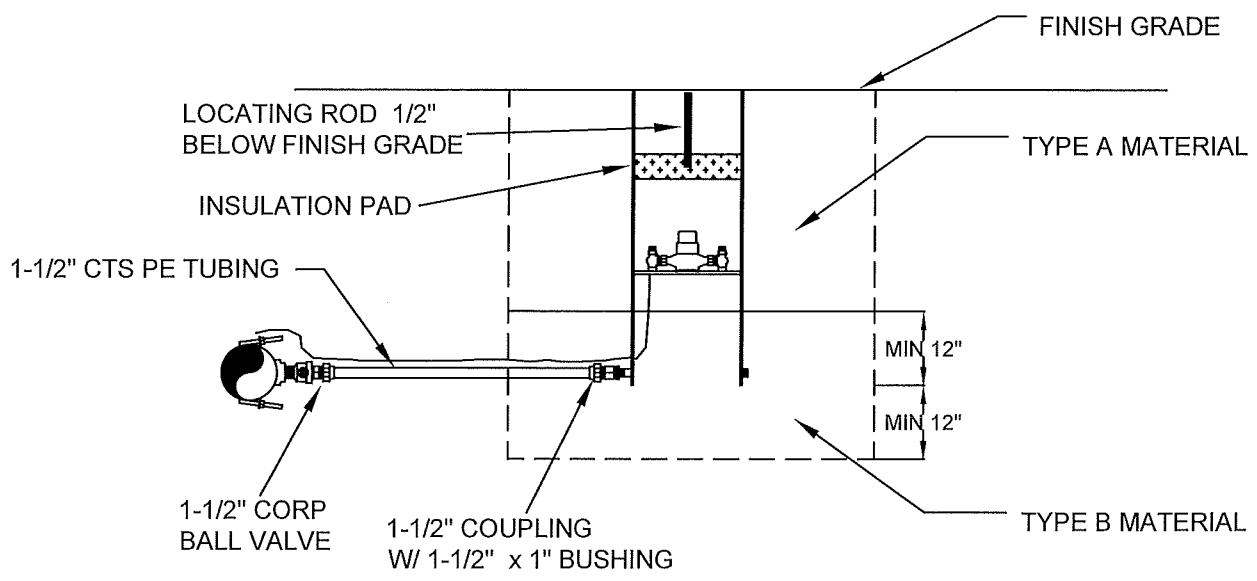

PROFILE VIEW

NOTES:

- 1) INSTALLATIONS WITHIN PAVED AREAS OR SUBJECT TO TRAFFIC LOADING REQUIRE TRAFFIC RATED BOXES. SEE DETAIL W-14.x
- 2) THIS DETAIL SHALL NOT BE USED FOR SINGLE FAMILY RESIDENTIAL SERVICES WHERE FIRE SPRINKLERS ARE REQUIRED

TECHNICAL SPECIFICATIONS		SINGLE PIT DOUBLE SERVICE DETAIL	DRAWING #	REVISED
02200			W-12.7	1-9-2017
02641		 TRUCKEE DONNER Public Utility District	SCALE	
02642			NO SCALE	
02643			DRAWN	APPROVED
			NK	NK

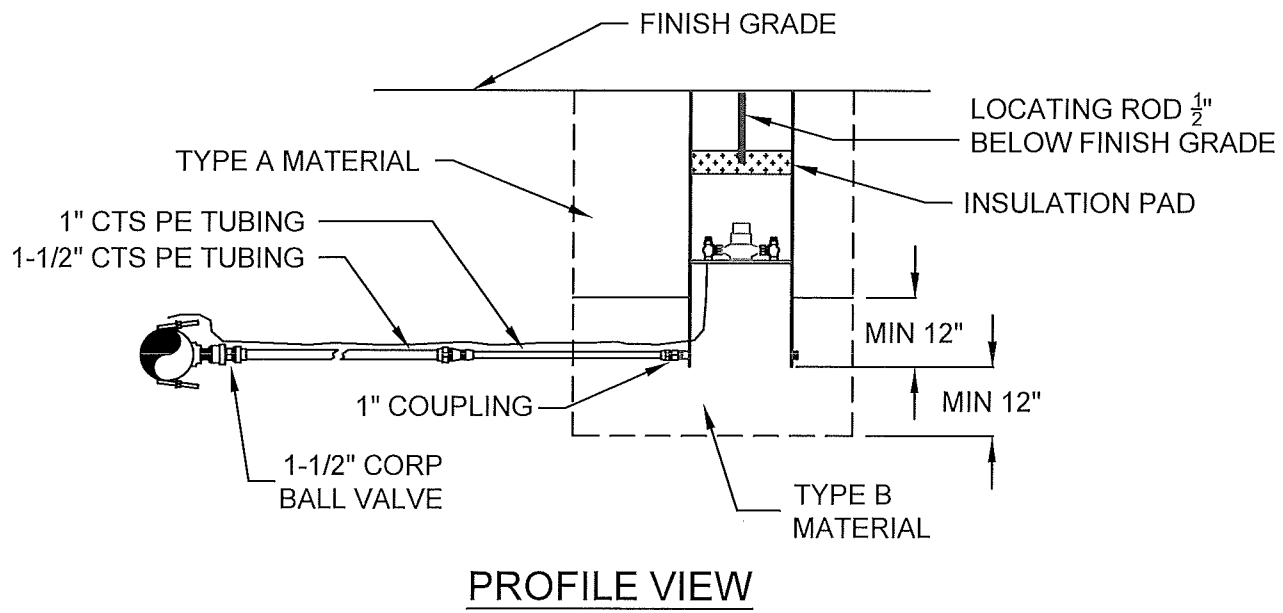
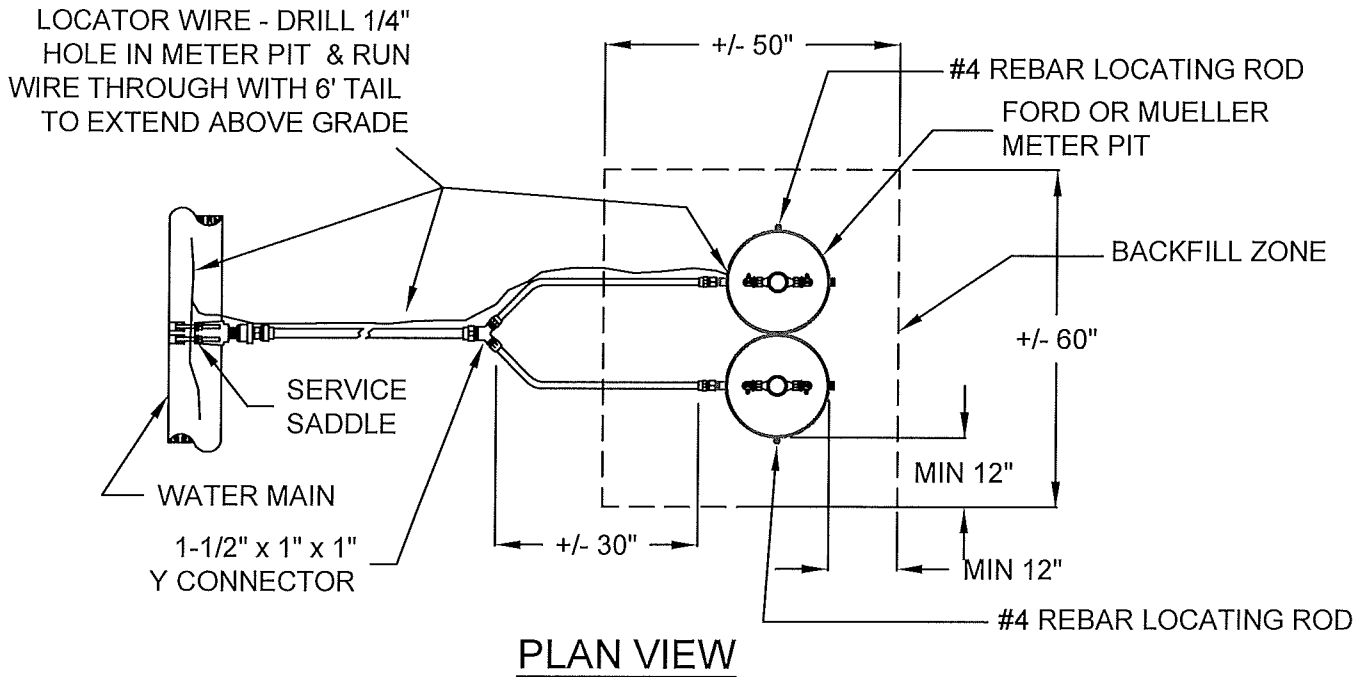

NOTES:

- 1) INSTALLATIONS WITHIN PAVED AREAS OR SUBJECT TO TRAFFIC LOADING REQUIRE TRAFFIC RATED BOXES. SEE DETAIL W-14.x
- 2) THIS DETAIL SHALL NOT BE USED FOR SINGLE FAMILY RESIDENTIAL SERVICES WHERE FIRE SPRINKLERS ARE REQUIRED

TECHNICAL SPECIFICATIONS		DOUBLE PIT DOUBLE SERVICE DETAIL	DRAWING #	REVISED
02200			W-13.6	1-9-2017
02641			SCALE	
02642			NO SCALE	
02643			DRAWN	APPROVED
			NK	NK

DOUBLE PIT INSTALLATIONS

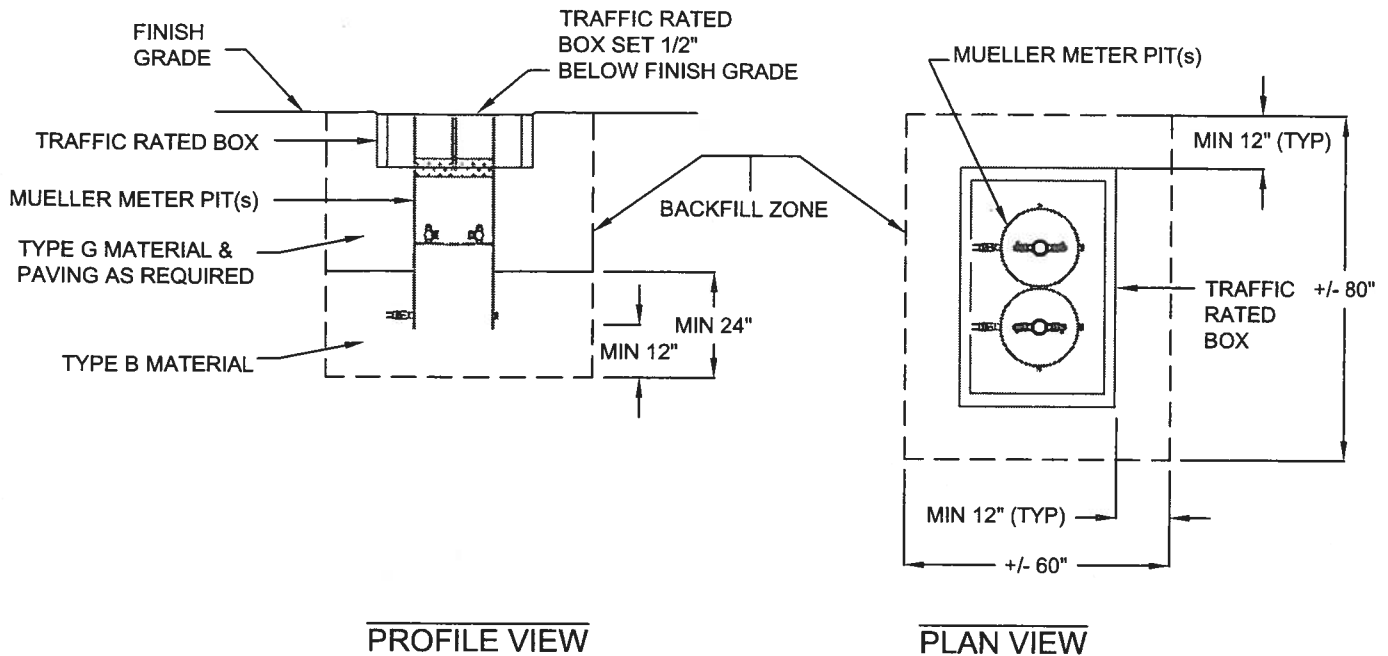

PROFILE VIEW

PLAN VIEW

SINGLE PIT INSTALLATIONS

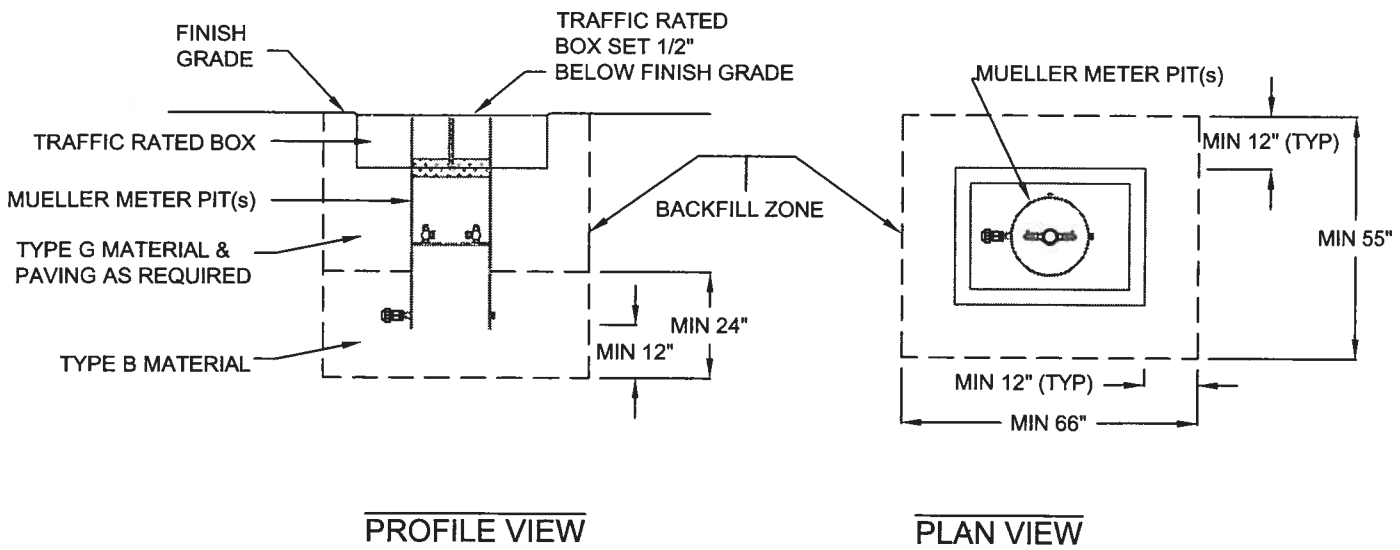

PROFILE VIEW

PLAN VIEW

TECHNICAL SPECIFICATIONS	TRUCKEE DONNER Public Utility District	DRAWING #	REVISED
02200		W-14.4	1-13-10
02641		SCALE	
02642		NO SCALE	
02643		DRAWN	APPROVED
		MC	NK

NOTE:

INSTALLATIONS WITHIN
PAVED AREAS OR
SUBJECT TO TRAFFIC
LOADING REQUIRE
TRAFFIC RATED BOXES.
SET TRAFFIC RATED
BOXES $\frac{1}{2}$ " BELOW FINISH
GRADE.

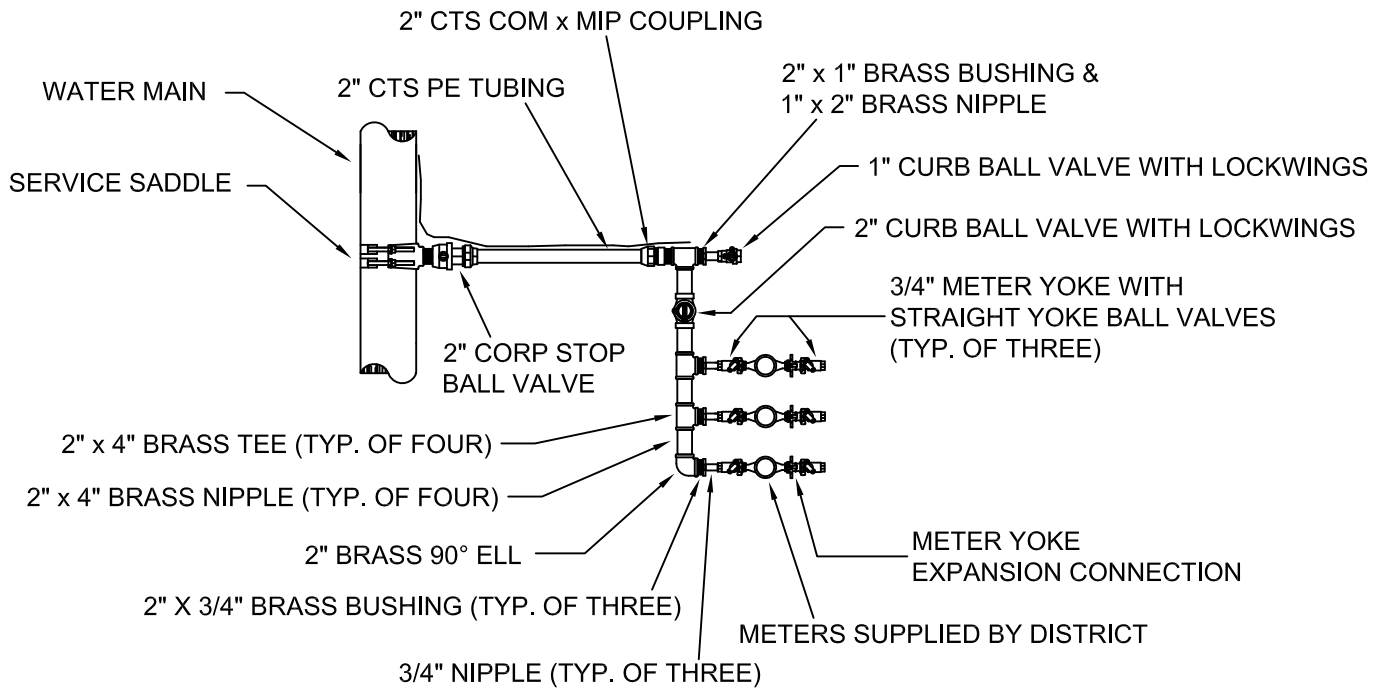
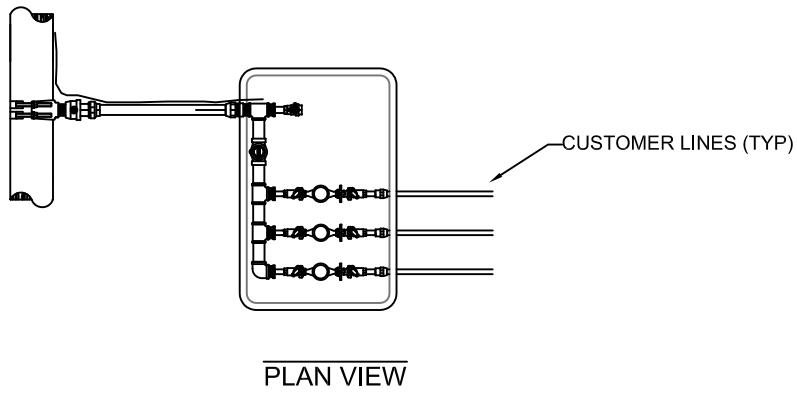
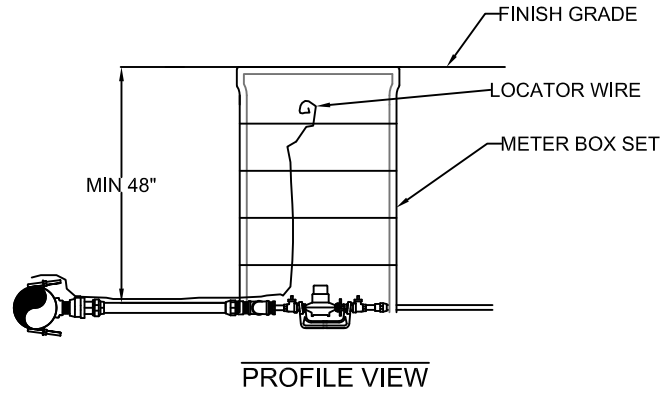

MATERIAL CALLOUT

TECHNICAL SPECIFICATIONS		 <p>TRUCKEE DONNER Public Utility District</p>	DRAWING #	REVISED
02200			W-15.7	1-8-2019
02641			SCALE	
02642			NO SCALE	
02643			DRAWN	APPROVED
		NK	NK	

THREE METER SERVICE DETAIL

DRAWING #
W-15.7

REVISED
1-8-2019

SCALE
NO SCALE

DRAWN
NK

APPROVED
NK

NOTE:

INSTALLATIONS WITHIN
PAVED AREAS OR
SUBJECT TO TRAFFIC
LOADING REQUIRE
TRAFFIC RATED BOXES.
SET TRAFFIC RATED
BOXES 1/2" BELOW FINISH
GRADE.

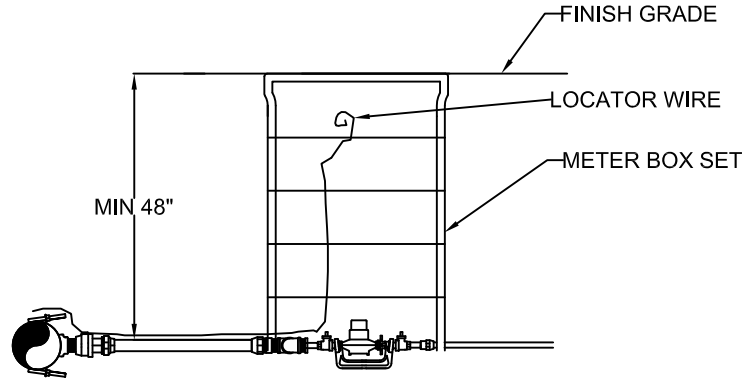

PROFILE VIEW

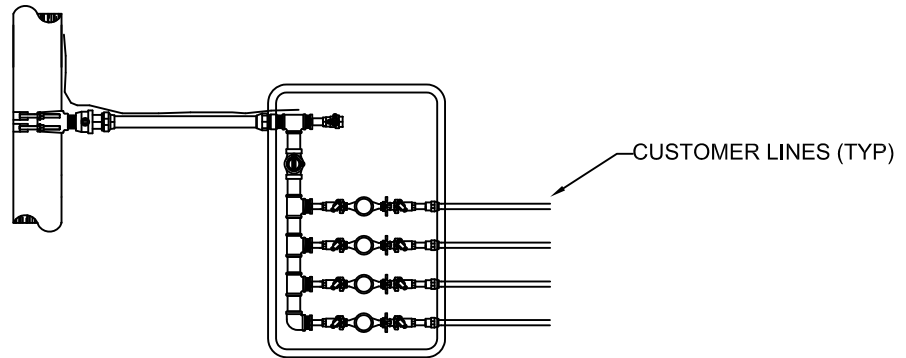

PLAN VIEW

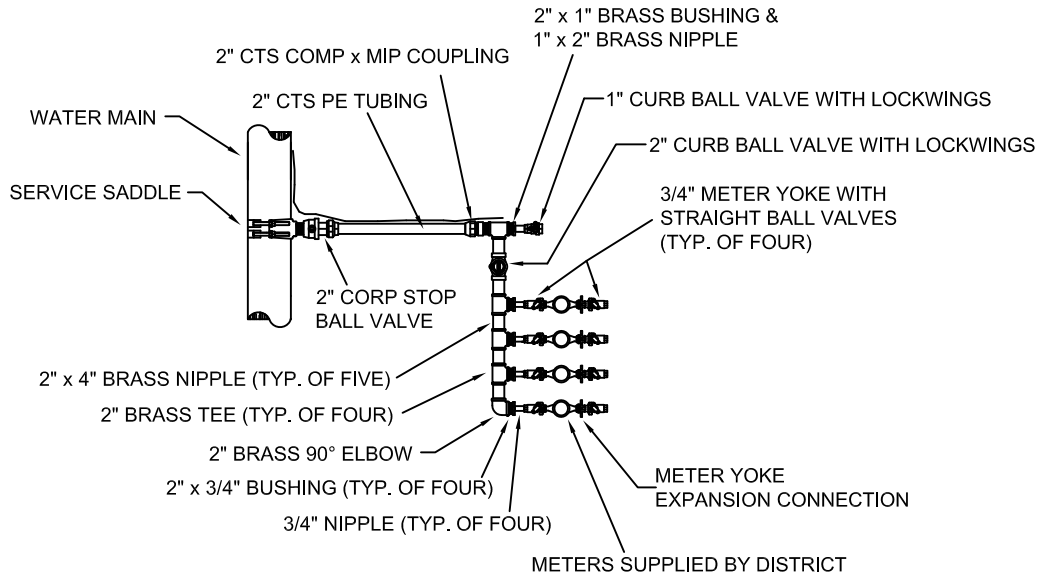

MATERIAL CALLOUT

TECHNICAL SPECIFICATIONS		 <p>TRUCKEE DONNER Public Utility District</p>	DRAWING #	REVISED
02200			W-16.6	1-8-2019
02641			SCALE	
02642			NO SCALE	
02643			DRAWN	APPROVED
		NK	NK	

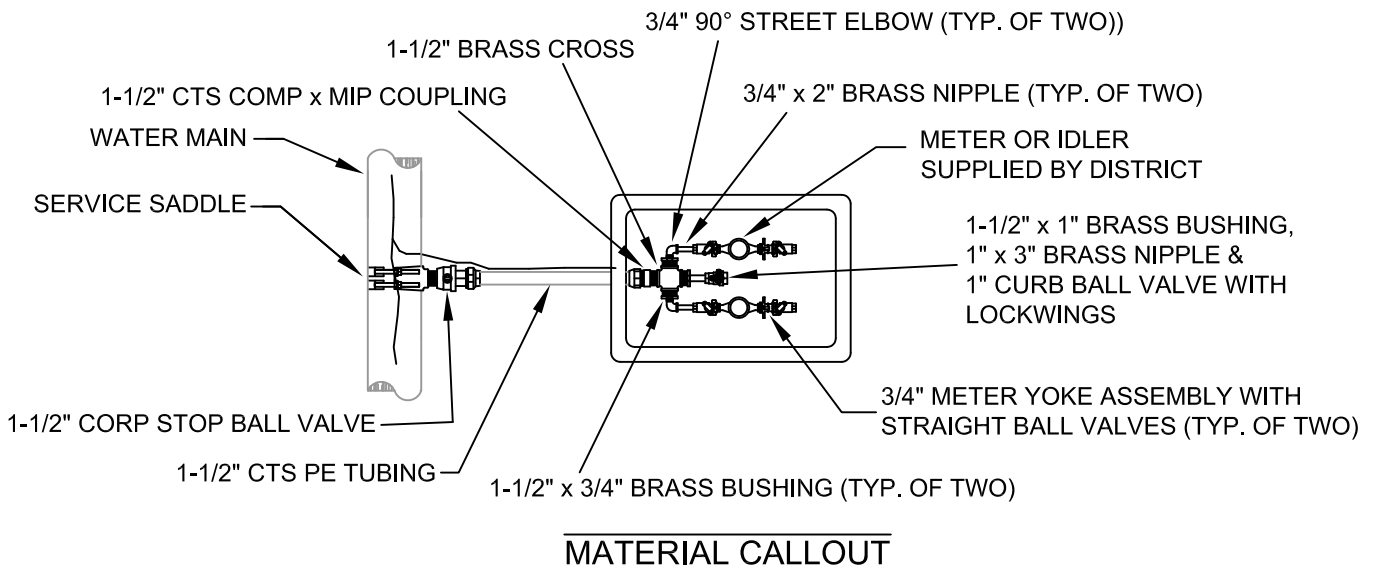
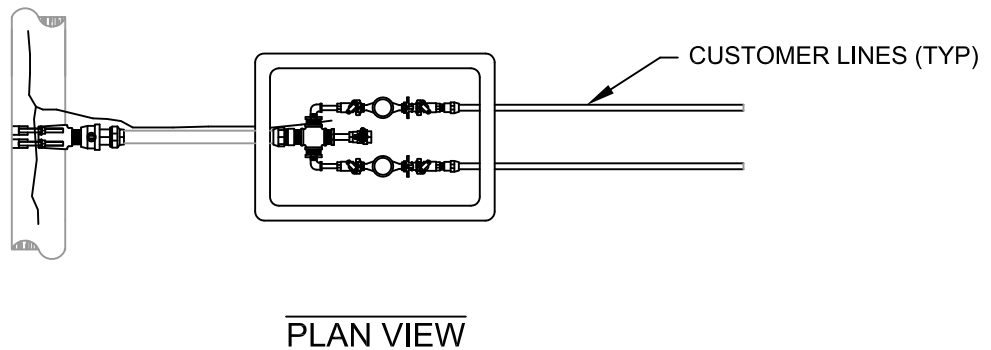
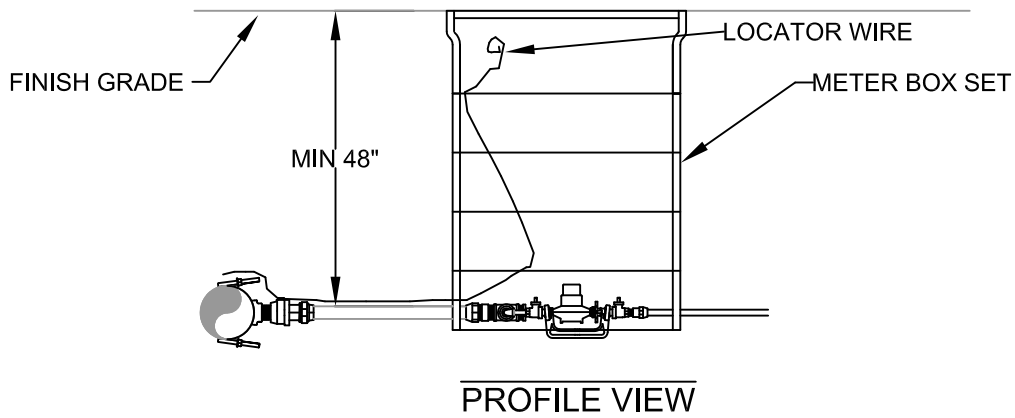

NOTES:

- 1) INSTALLATIONS WITHIN PAVED AREAS OR SUBJECT TO TRAFFIC LOADING REQUIRE TRAFFIC RATED BOXES. SET TRAFFIC RATED BOXES 1/2" BELOW FINISH GRADE.
- 2) THIS DETAIL SHALL NOT BE USED FOR SINGLE FAMILY RESIDENTIAL SERVICES WHERE FIRE SPRINKLERS ARE REQUIRED

TECHNICAL SPECIFICATIONS		DOUBLE SERVICE DETAIL WITH PRECAST CONCRETE BOXES	DRAWING #	REVISED
02200			W-18.6	1-8-2019
02641		 TRUCKEE DONNER Public Utility District	SCALE	
02643			NO SCALE	
			DRAWN	APPROVED
		NK	NK	

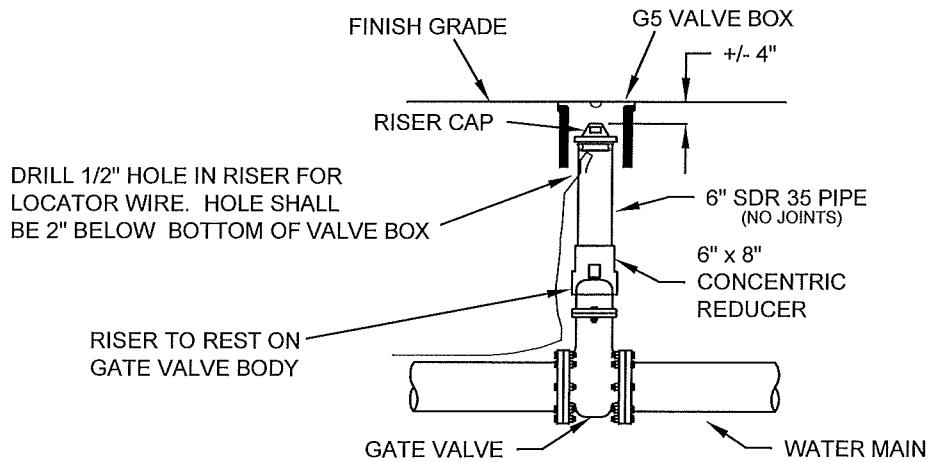

NOTES:

- 1) LOCATOR WIRE LOOP SHALL REACH MINIMUM 12" ABOVE FINISH GRADE
- 2) THE 8" x 6" CONCENTRIC REDUCER MAY BE DELETED ON SMALL DIAMETER GATE VALVES WHERE THE 6" RISER PIPE CLEARS THE LIFTING LUGS SUCH THAT THE RISER RESTS SECURELY ON THE VALVE BODY WITHOUT NOTCHING OR CUTTING

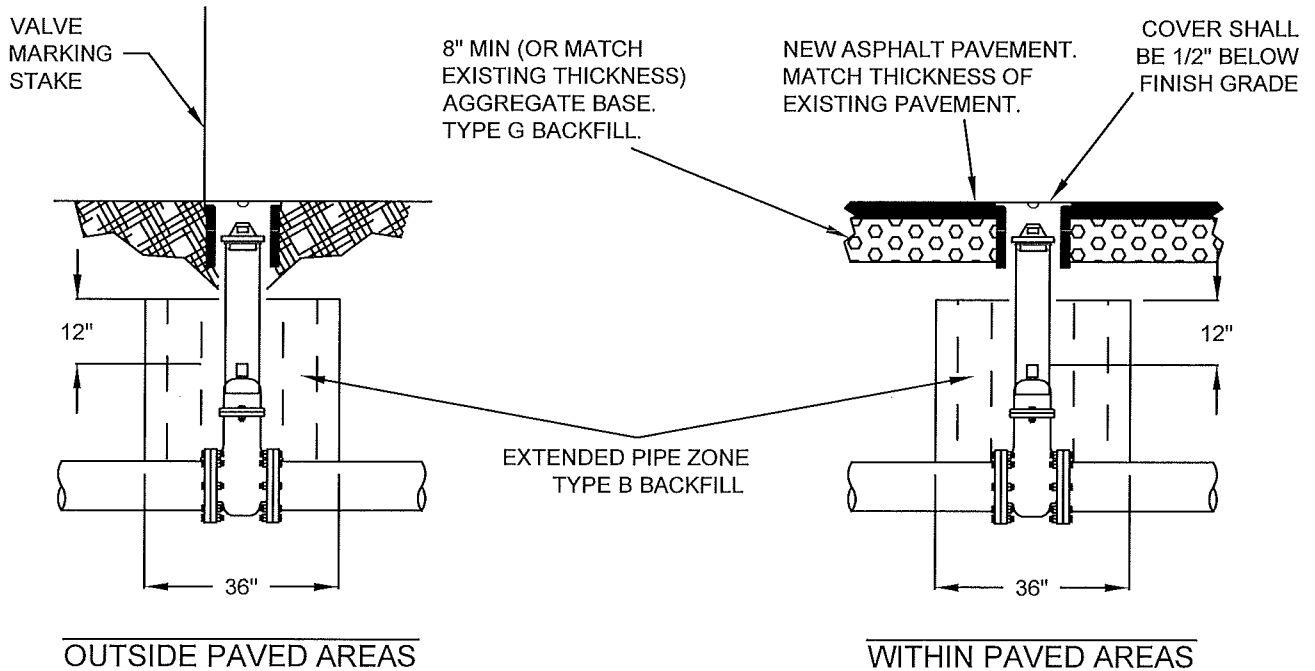

TECHNICAL SPECIFICATIONS		GATE VALVE DETAIL	DRAWING #	REVISED
02200			W-20.4	1-9-2017
02460		 TRUCKEE DONNER Public Utility District	SCALE	
02565			NO SCALE	
02643			DRAWN	APPROVED
15206			NK	NK

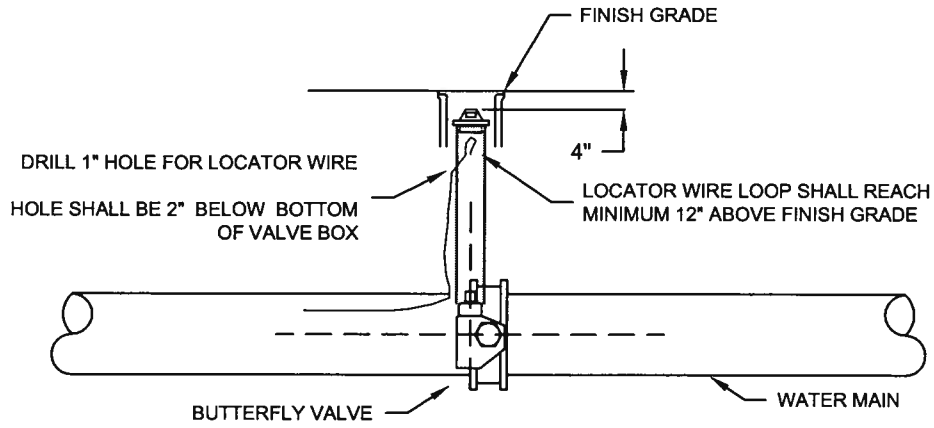

DIMENSIONAL LAYOUT

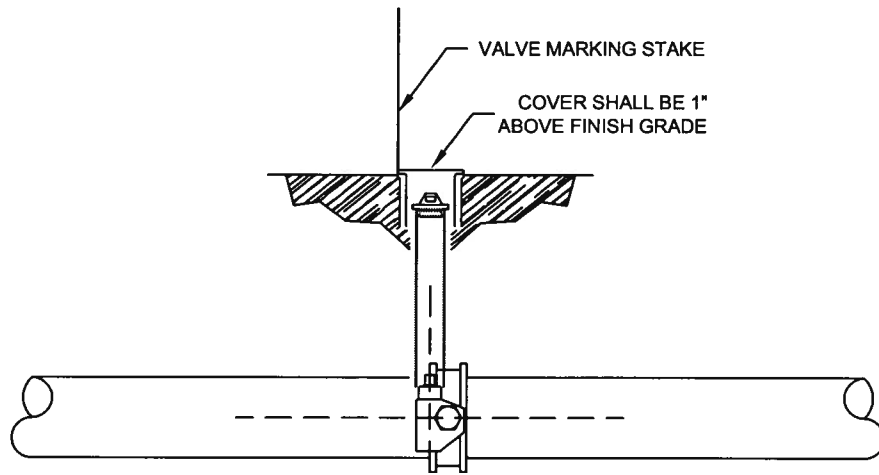

OUTSIDE PAVED AREAS

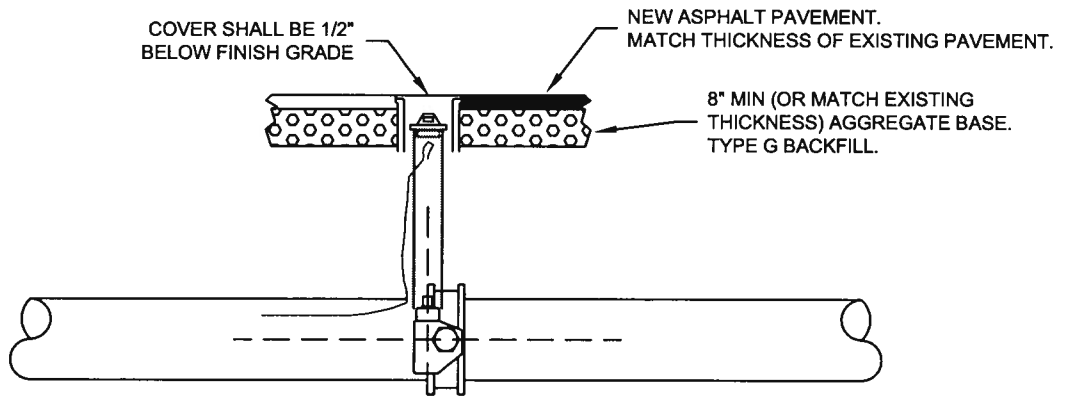

WITHIN PAVED AREAS

TECHNICAL SPECIFICATIONS	
02200	
02460	
02565	
02643	
15202	

BUTTERFLY VALVE DETAIL





TRUCKEE DONNER
Public Utility District

DRAWING # W-21.2	REVISED 2-21-06
SCALE NO SCALE	
DRAWN MC	APPROVED NK

CONSTRUCTION NOTES:

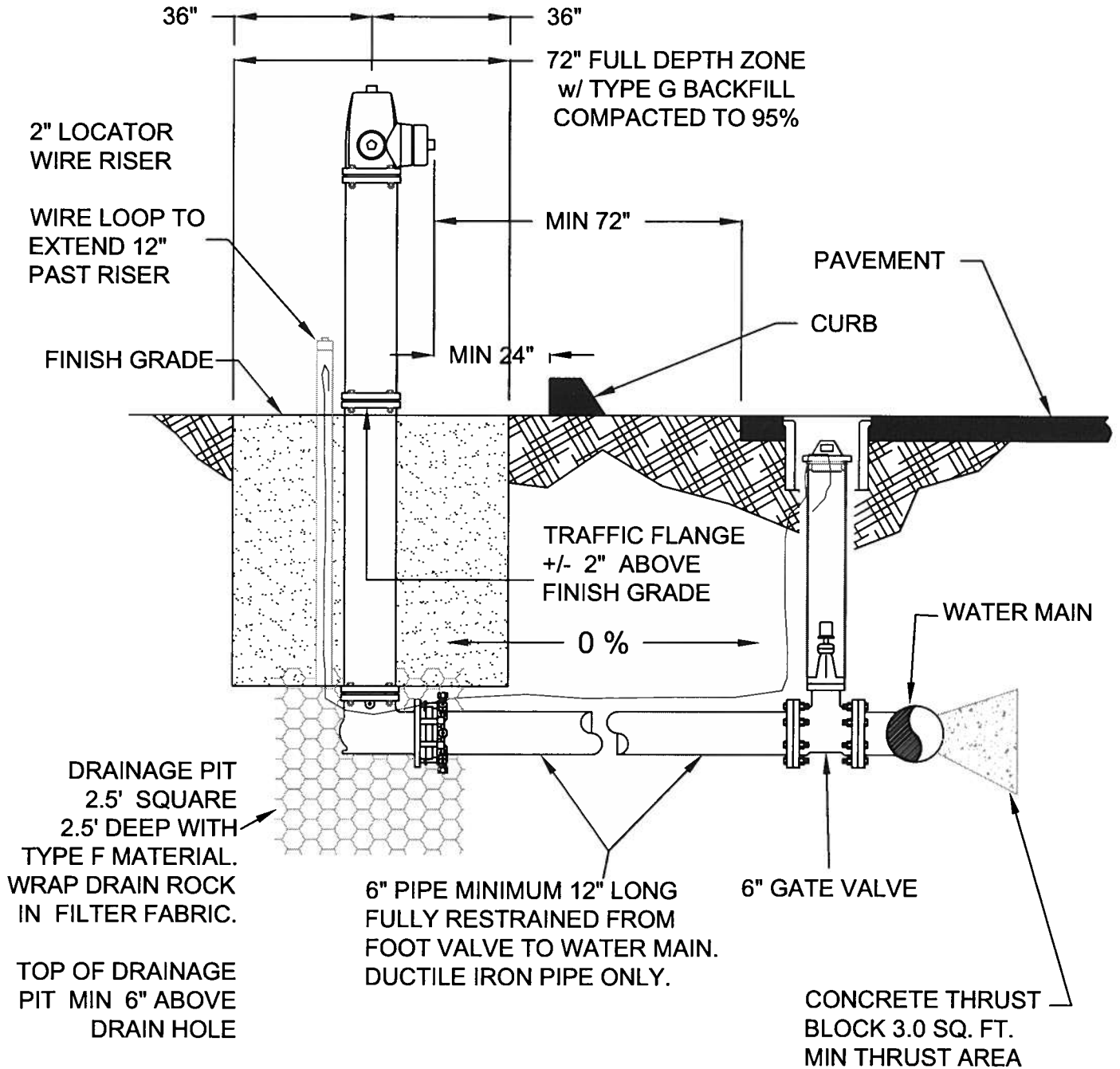
1. PROTECTIVE BARRIER POSTS MAY BE REQUIRED (SEE W-46.1).
2. FIRE HYDRANTS SHALL BE INSTALLED A MINIMUM DISTANCE OF SIX (6) FEET BEHIND THE EDGE OF PAVEMENT OR TWO (2) FEET BEHIND ASPHALT CEMENT DIKE, IF AN ASPHALT CEMENT DIKE IS PRESENT.



TECHNICAL SPECIFICATIONS		FIRE HYDRANT DETAIL	DRAWING #	REVISED
02200	W-23.1		W-22.6	2-28-06
02565	W-24.1		SCALE	
02643			NO SCALE	
15206		 TRUCKEE DONNER Public Utility District	DRAWN	APPROVED
15235			MC	NK

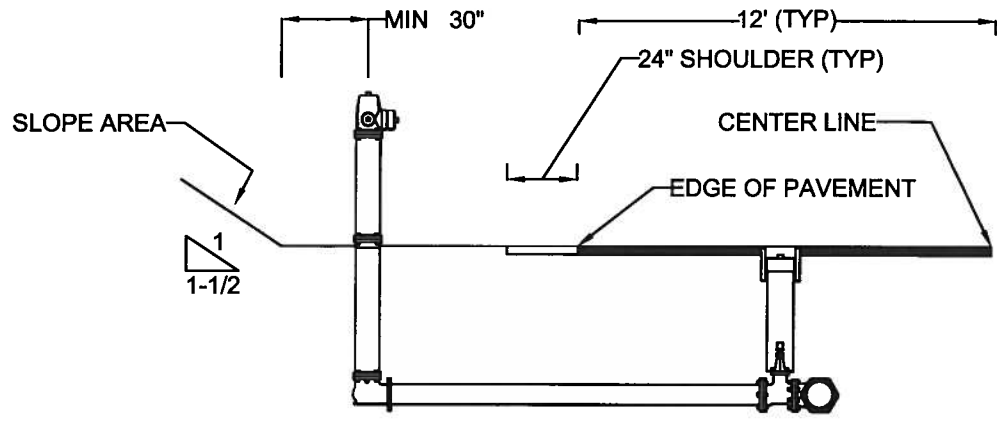

PROFILE VIEW

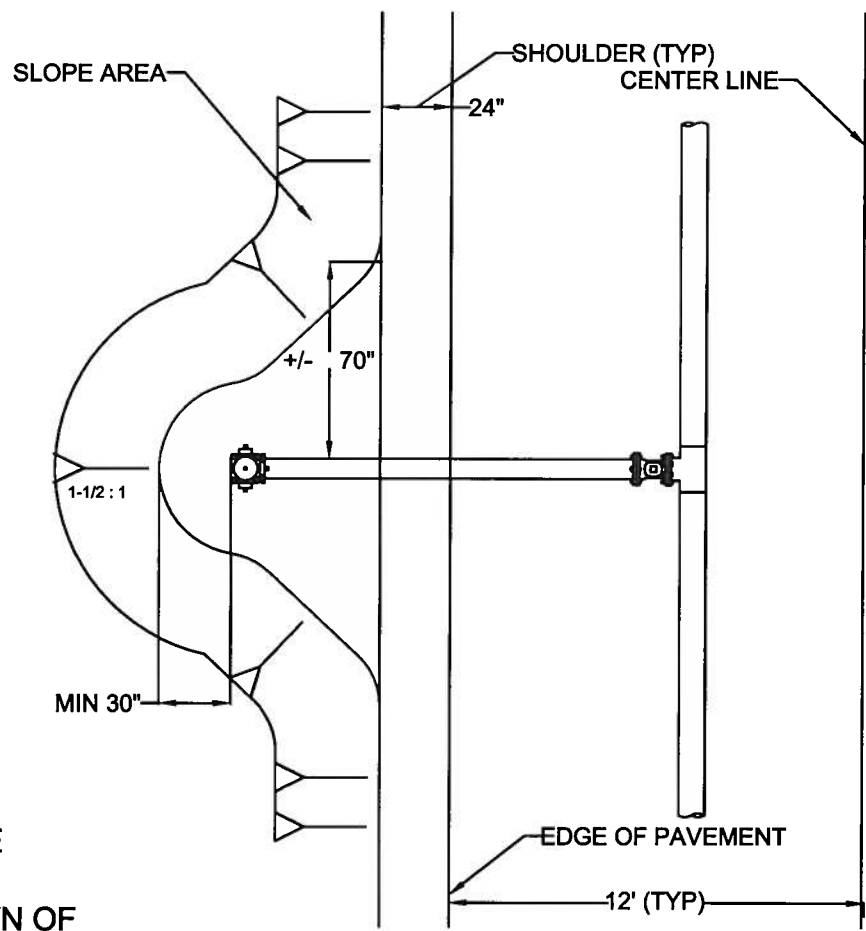

PLAN VIEW

NOTE:

SLOPE AREA TO BE PROTECTED FROM EROSION PER TOWN OF TRUCKEE REQUIREMENTS.

TECHNICAL SPECIFICATIONS		FIRE HYDRANT CUT SLOPE PAD	DRAWING #	DATE
02200			W-23.1	2-15-05
02460			SCALE	
15235		 TRUCKEE DONNER Public Utility District	NO SCALE	
			DRAWN	APPROVED
			MC	

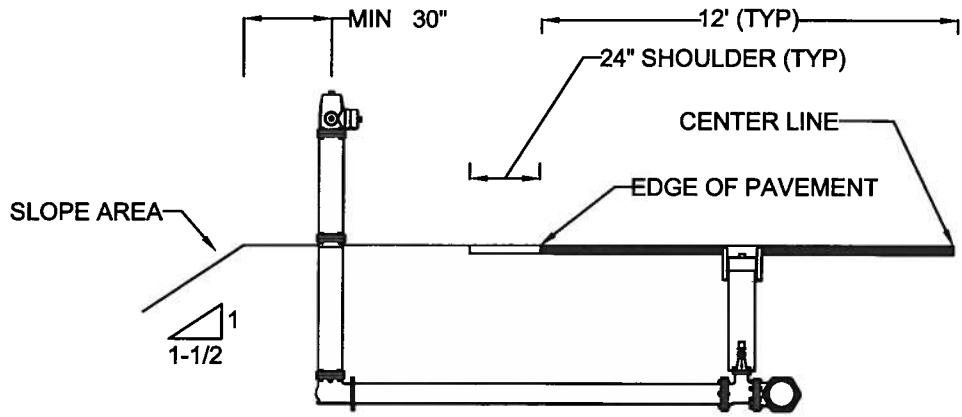

PROFILE VIEW

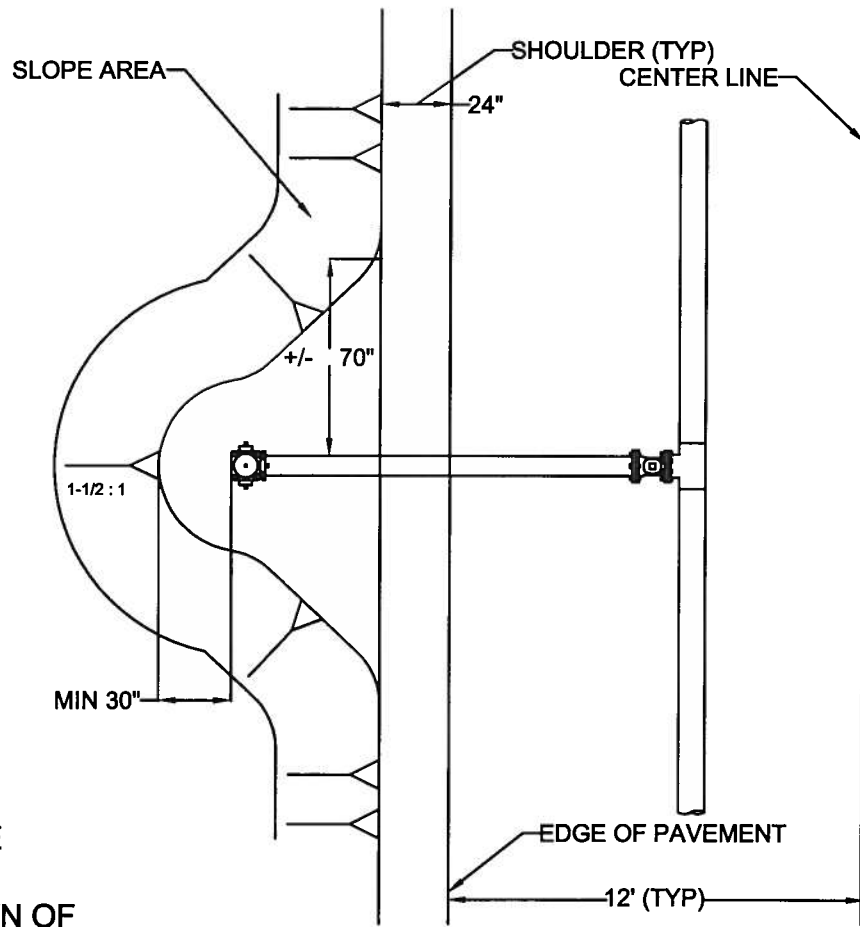

PLAN VIEW

NOTE:

SLOPE AREA TO BE PROTECTED FROM EROSION PER TOWN OF TRUCKEE REQUIREMENTS.

TECHNICAL SPECIFICATIONS		FIRE HYDRANT FILL SLOPE PAD	DRAWING #	DATE
02200			W-24.1	2-15-05
02460			SCALE	
15235		 TRUCKEE DONNER Public Utility District	NO SCALE	
			DRAWN	APPROVED
			MC	

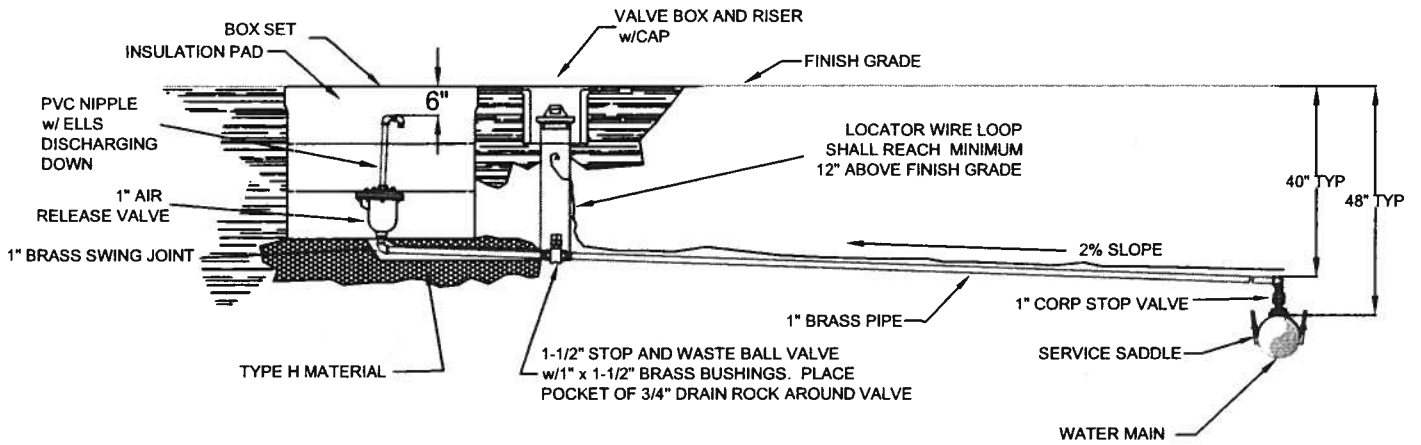

CONSTRUCTION NOTES:

1. INSTALLATIONS WITHIN PAVED AREAS OR SUBJECT TO VEHICULAR LOADING REQUIRE TRAFFIC RATED BOXES. SET TRAFFIC RATED LIDS 1/2" BELOW FINISH GRADE.
2. AIR RELEASE VALVE TO BE CENTERED WITHIN BOXES. EQUIDISTANT FROM SIDE & END WALLS.

TECHNICAL SPECIFICATIONS		1" AIR RELEASE VALVE DETAIL	DRAWING #	REVISED
02200			W-30.6	12-26-07
02565		 TRUCKEE DONNER Public Utility District	SCALE	
02643			NO SCALE	
15232			DRAWN	APPROVED
			MC	NK

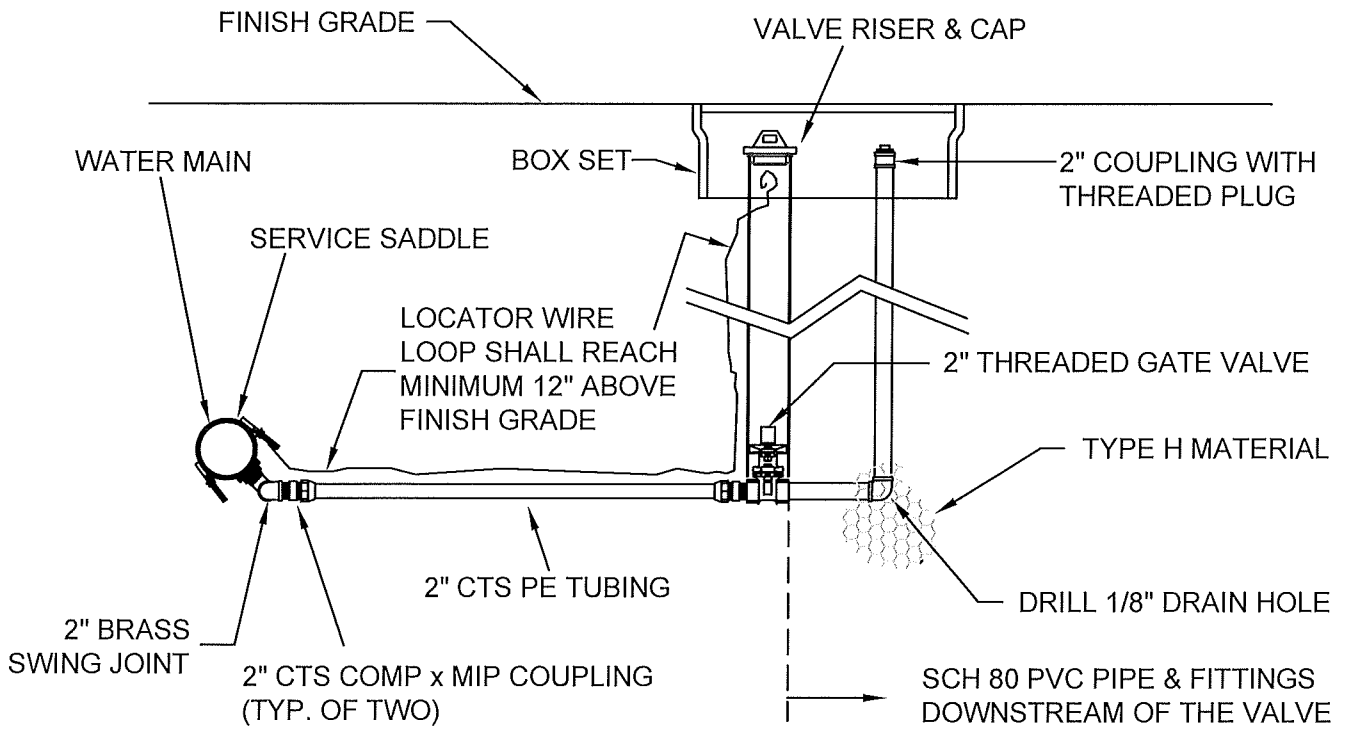

NOTE:

1. SET TAPPING SADDLE AT 45° OFFSET FROM VERTICAL.
2. INSTALLATIONS WITHIN PAVED AREAS OR SUBJECT TO VEHICULAR LOADING REQUIRE TRAFFIC RATED BOXES. SET TRAFFIC RATED BOXES $\frac{1}{2}$ " BELOW FINISH GRADE.

TECHNICAL SPECIFICATIONS		2" BLOW OFF DETAIL	DRAWING #	REVISED
02200				W-34.6
02565			SCALE	
02643			NO SCALE	
15231		 TRUCKEE DONNER Public Utility District	DRAWN	APPROVED
			MC	NK

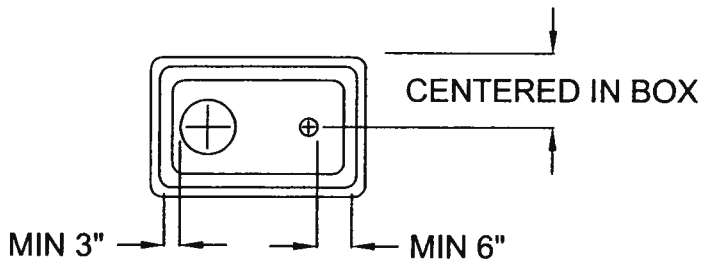

PLAN VIEW

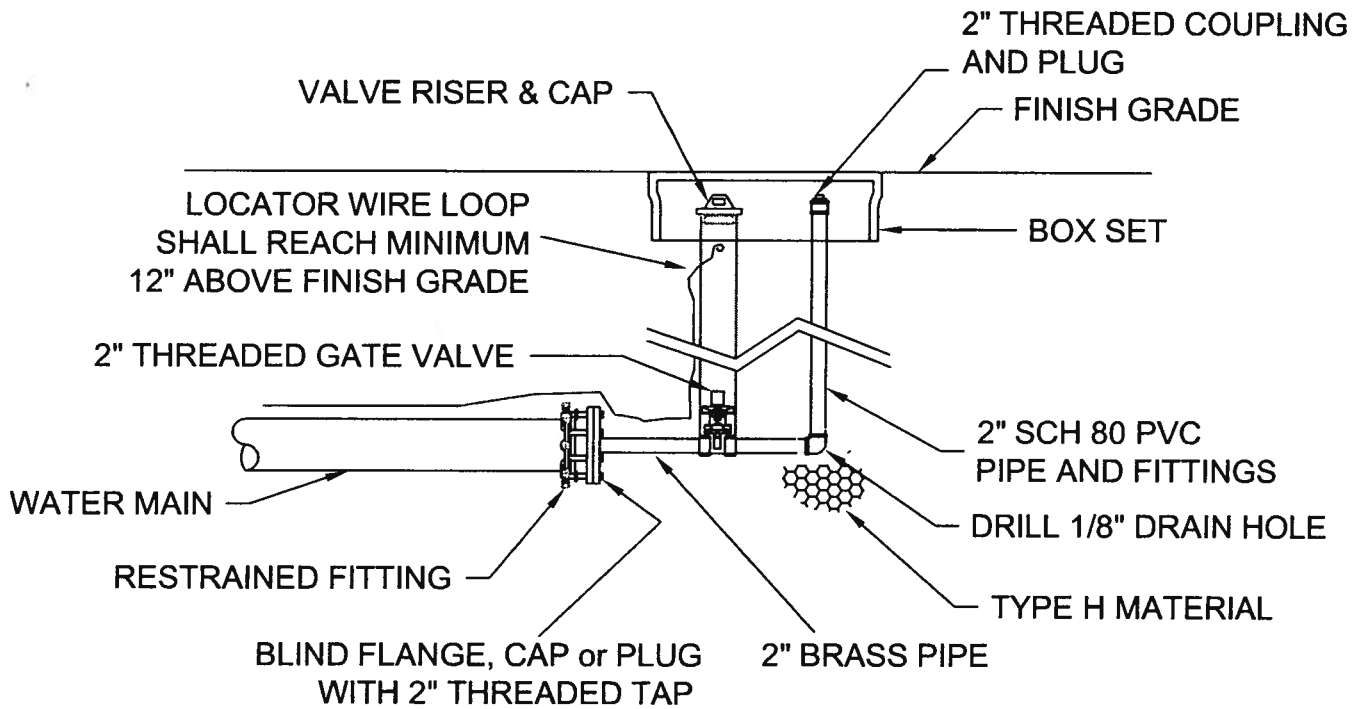

PROFILE VIEW

NOTE:

INSTALLATIONS WITHIN PAVED AREAS OR SUBJECT TO VEHICULAR LOADING REQUIRE TRAFFIC RATED BOXES. SET TRAFFIC RATED BOXES $\frac{1}{2}$ " BELOW FINISH GRADE.

TECHNICAL SPECIFICATIONS		2" END OF PIPE BLOW OFF DETAIL	DRAWING #	REVISED
02200			W-35.4	12-26-07
02565		 TRUCKEE DONNER Public Utility District	SCALE	
02643			NO SCALE	
15231			DRAWN	APPROVED
			MC	NK

LOT A

LOT B

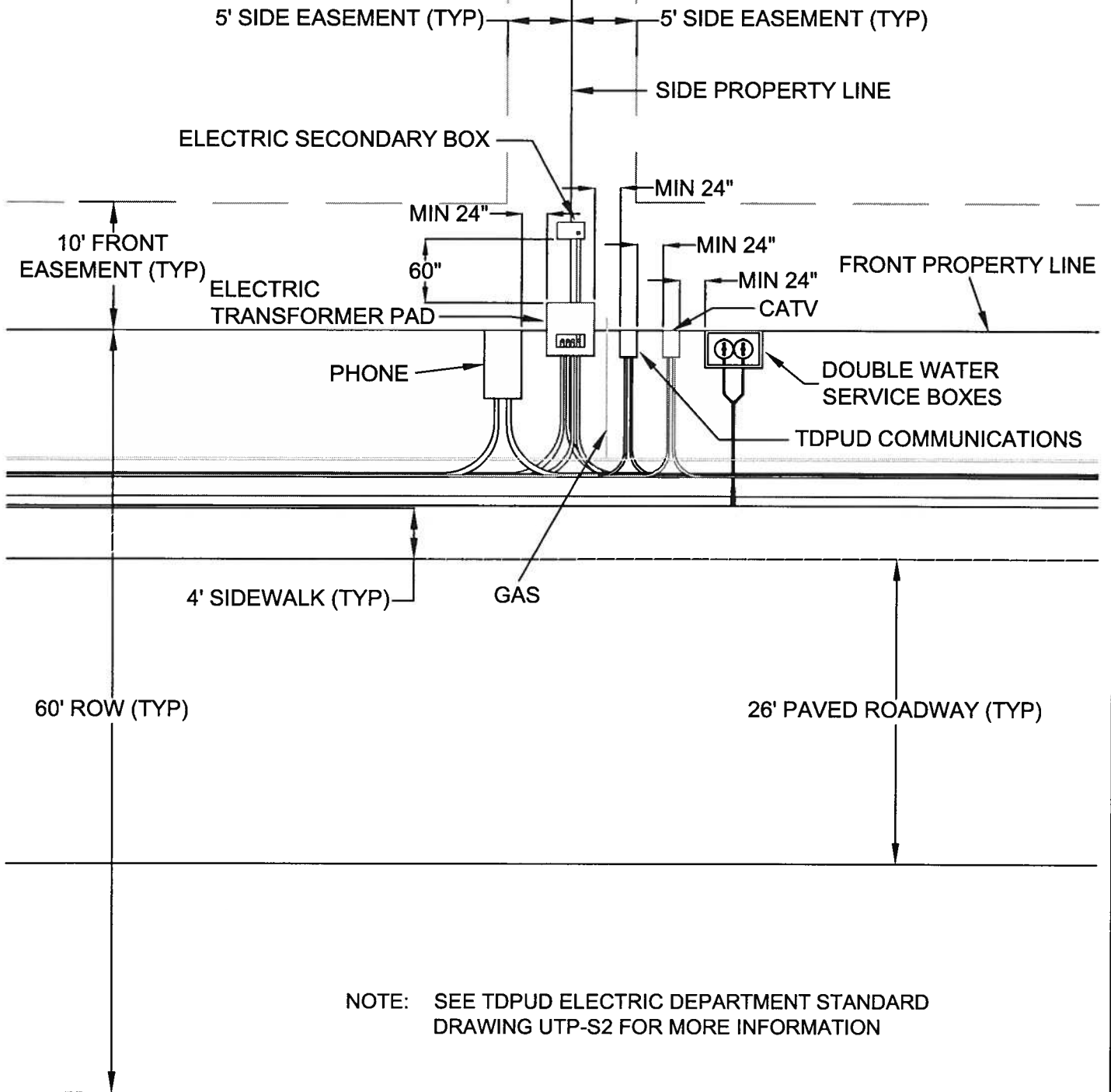

TECHNICAL SPECIFICATIONS		TYPICAL UTILITY LOCATIONS AT PROPERTY CORNERS	DRAWING #	DATE
02200			 TRUCKEE DONNER Public Utility District	W-41.3
02460		SCALE		
02641		NO SCALE		
02643		DRAWN		APPROVED
			MC	NK

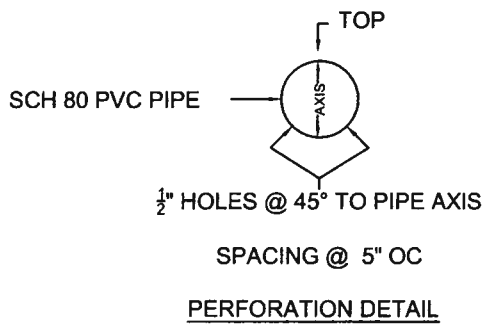
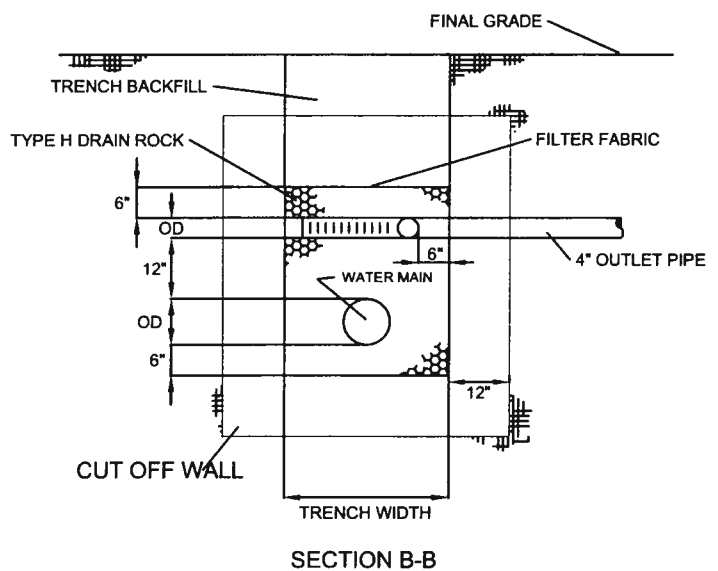
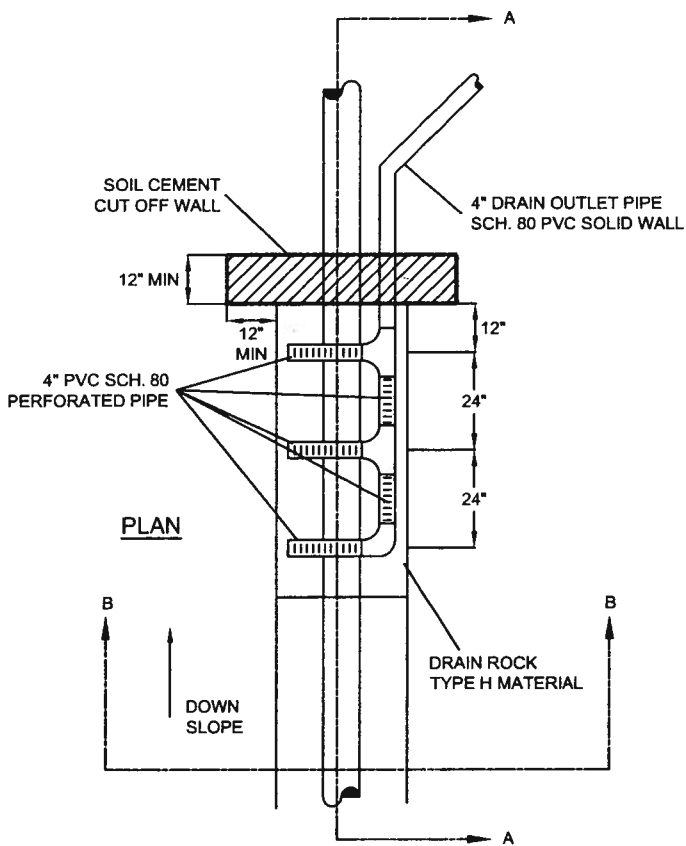
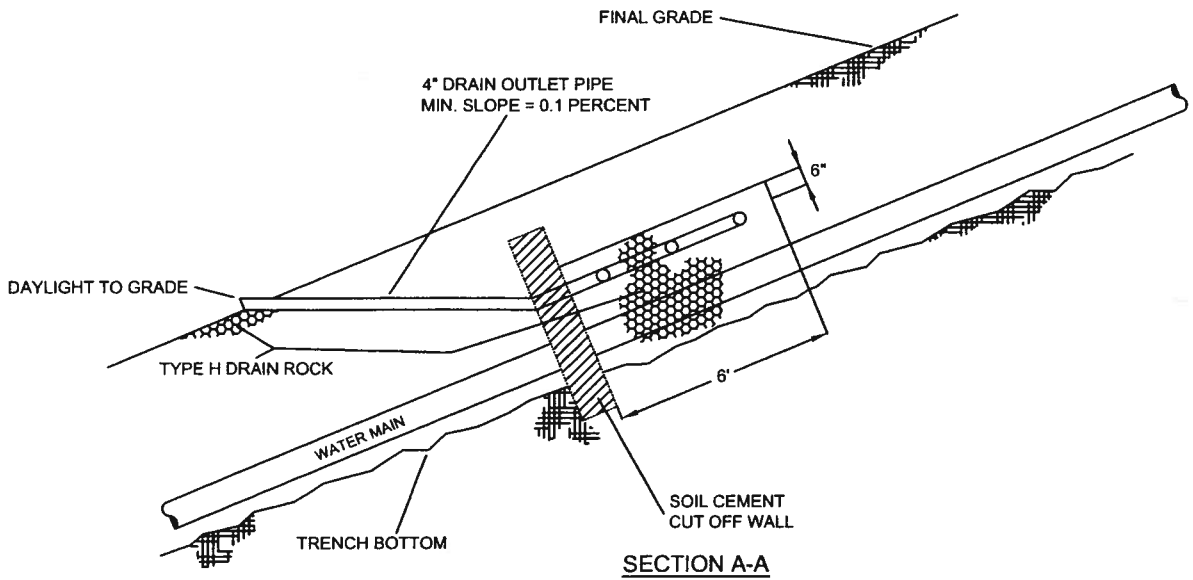

TECHNICAL SPECIFICATIONS	
02200	
02225	

CUTOFF WALL DETAIL



TRUCKEE DONNER
Public Utility District

DRAWING # W-43.2	REVISED 12-20-07
SCALE NO SCALE	
DRAWN MC	APPROVED NK

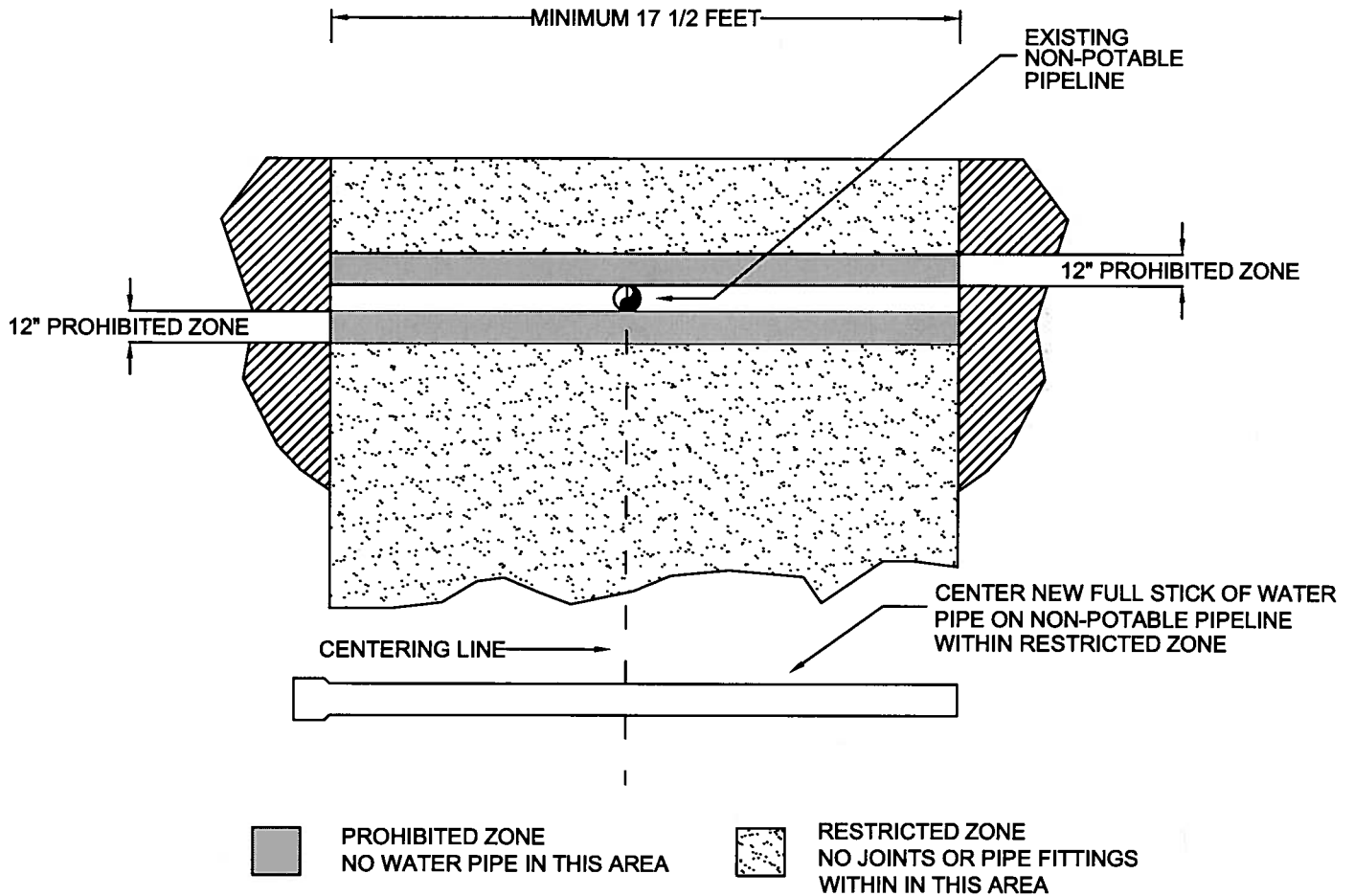

TECHNICAL SPECIFICATIONS	REQUIRED VERTICAL SEPARATION BETWEEN		DRAWING #	REVISED
	WATER AND NON-POTABLE PIPELINES		W-44.2	3-18-04
	 TRUCKEE DONNER Public Utility District		SCALE	
			NO SCALE	
			DRAWN	APPROVED
			MC	NK

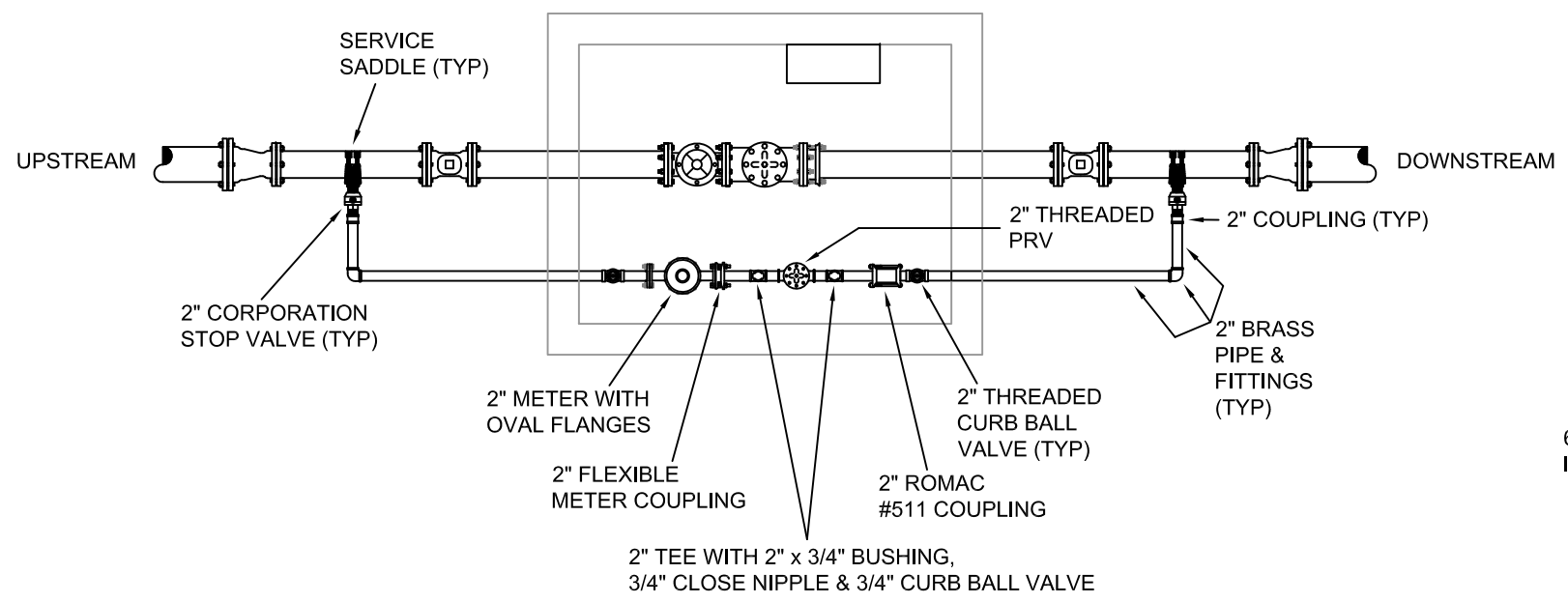

2" PRV PLAN VIEW

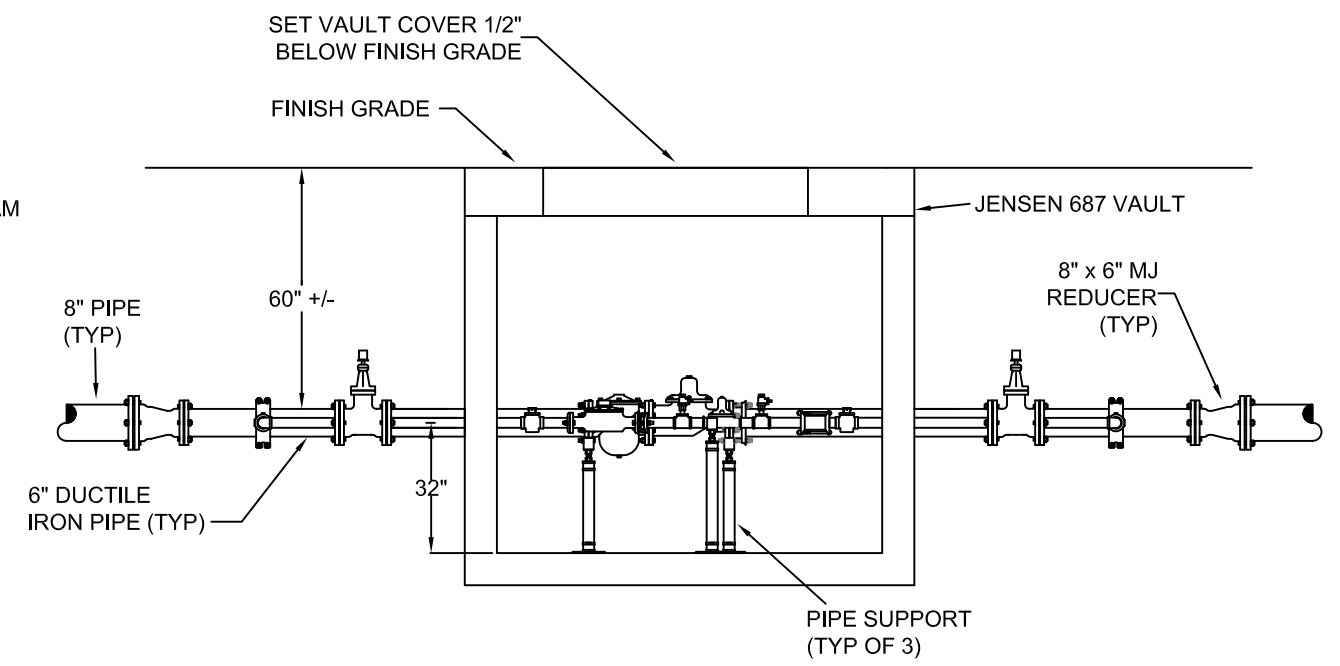

PROFILE VIEW

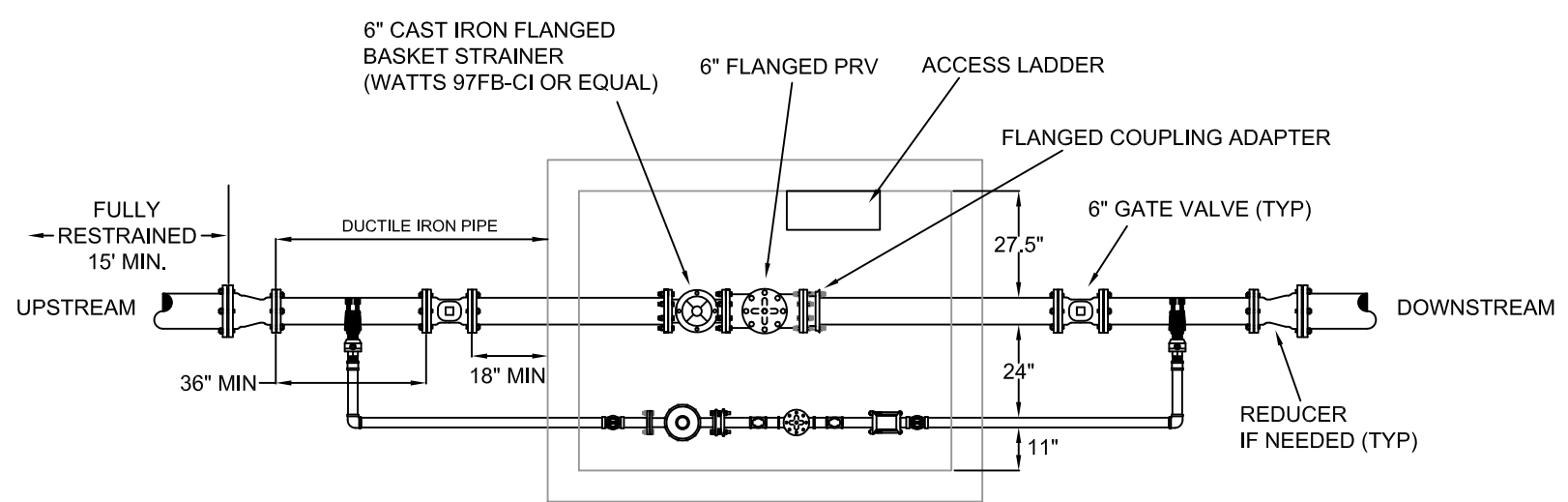

6" PRV PLAN VIEW

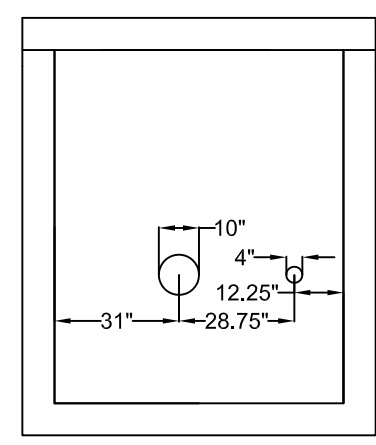

WALL PENETRATIONS

NOTES:

1. WALL PENETRATIONS FOR THE 6" & 2" PIPING SHALL BE FACTORY CAST OR CORE DRILLED BY VAULT MANUFACTURER.
2. ANNULAR SPACE BETWEEN POTABLE WATER PIPE AND THE VAULT WALL SHALL BE SEALED WITH "LINK-SEAL" MODULAR SEALS OR APPROVED EQUAL.
3. LOCATION & ROUTING OF SUMP PUMP DISCHARGE PIPE PER DISTRICT DIRECTION FOLLOWING FIELD REVIEW.
4. WALL PENETRATIONS FOR THE SUMP PUMP DISCHARGE PIPE, POWER CONDUIT AND COMMUNICATIONS CONDUIT MAY BE FACTORY CAST, CORE DRILLED OR FIELD DRILLED.
5. ANNULAR SPACE BETWEEN PVC PIPE OR CONDUIT AND THE VAULT WALL SHALL BE GROUTED

TECHNICAL SPECIFICATIONS	
02200	
02565	
02641	
02643	
15233	

6" PRESSURE REDUCING STATION DETAIL

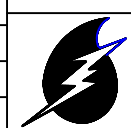

TRUCKEE DONNER
Public Utility District

DRAWING #	W-45.8	REVISED	2-10-2019
SCALE	NO SCALE		
DRAWN	NK	APPROVED	NK

CONSTRUCTION NOTES:

1. QUANTITY & PLACEMENT OF POSTS PER TDPUD DIRECTION.
2. POSTS TO BE PLUMB.
3. POSTS TO BE PAINTED PER SPECIFICATION.

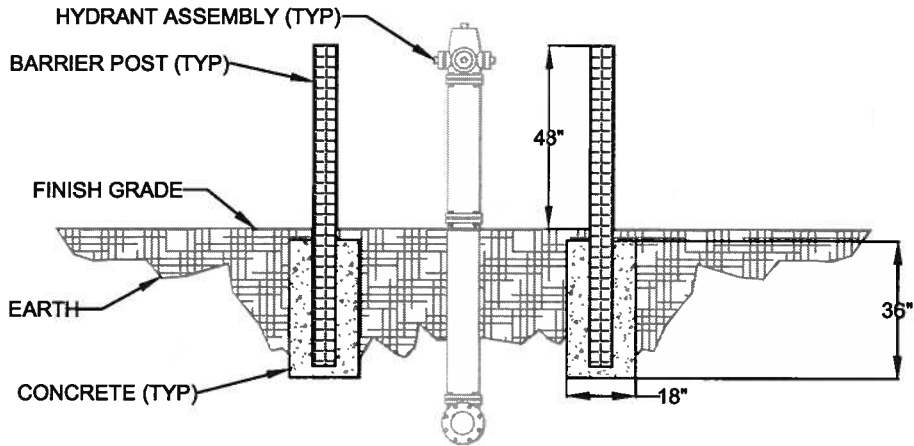

PROFILE VIEW

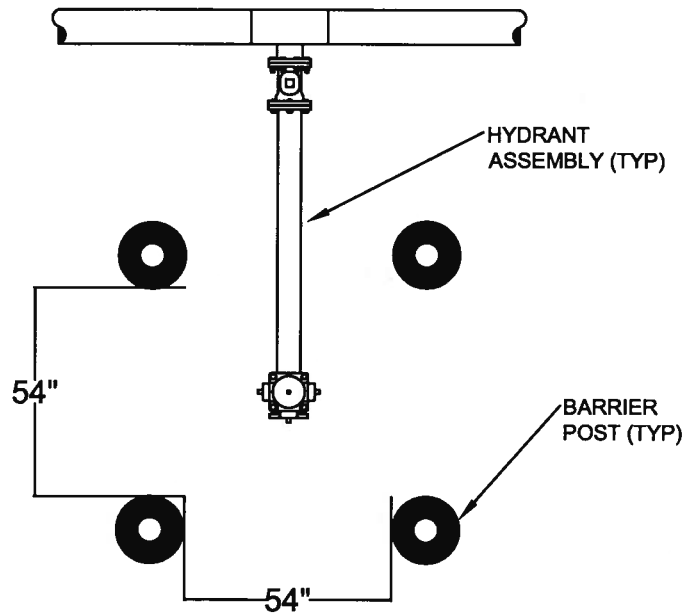

PLAN VIEW

TECHNICAL SPECIFICATIONS		BARRIER POST DETAIL	DRAWING #	REVISED
15235			W-46.1	2-6-04
		 TRUCKEE DONNER Public Utility District	SCALE	
			NO SCALE	
			DRAWN	APPROVED
			MC	NK

VALVE & GAUGE ASSEMBLY

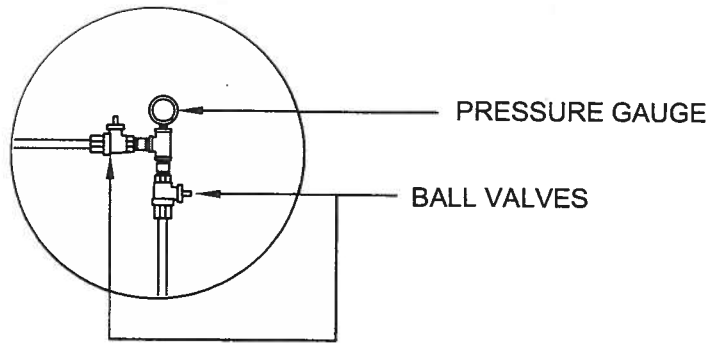

NOTES

- 1) ALL FITTINGS & MATERIALS TO BE RATED FOR THE TEST PRESSURES.
- 2) GAUGE REQUIREMENTS:
 - LIQUID FILLED
 - RANGE = 0-300 PSI
 - MAX INCREMENTS OF 5 PSI.

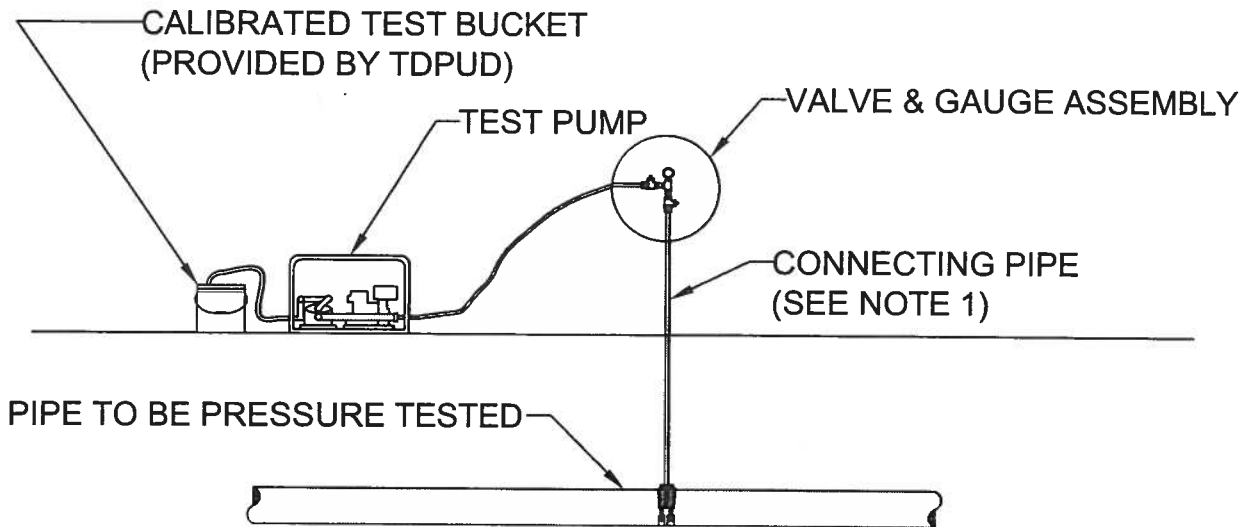

NOTE #1

CONNECTING PIPING IS TYPICALLY A SERVICE LATERAL OR OTHER APPUTENANCE CONSTRUCTED WITH NEW PIPELINE. CONFIRM WITH TDPUD INSPECTOR PRIOR TO SETTING UP FOR PRESSURE TEST.

TECHNICAL SPECIFICATIONS		HYDROSTATIC PRESSURE TESTING SETUP DETAIL	DRAWING # W-48.1	DATE MAR-2009
			SCALE NO SCALE	
		 TRUCKEE DONNER Public Utility District	DRAWN MC	APPROVED NK

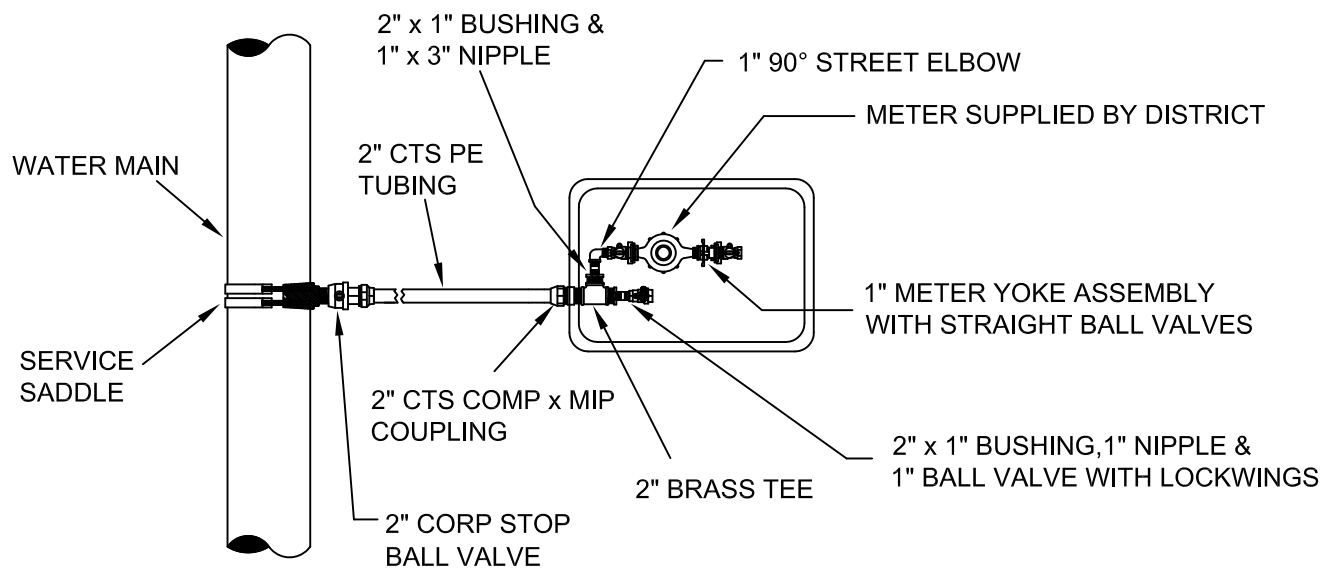

PLAN VIEW

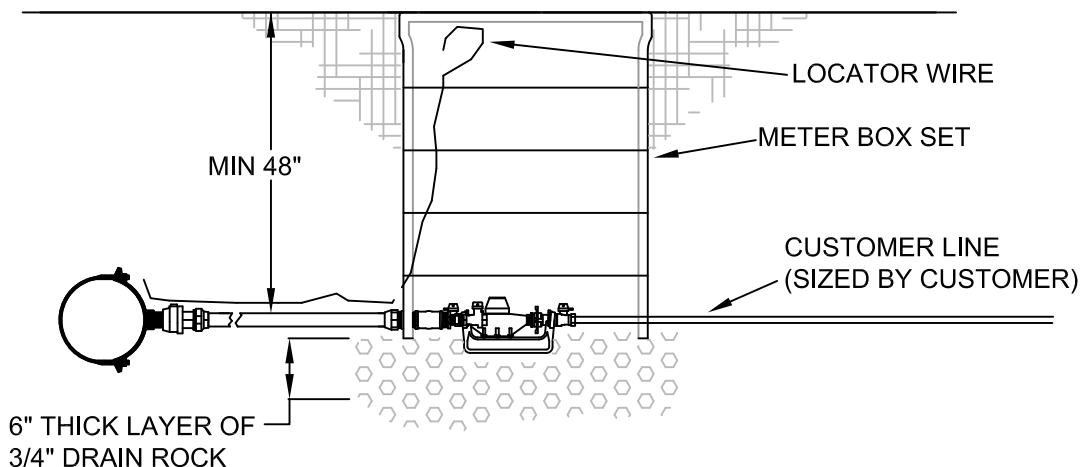

PROFILE VIEW

NOTES:

- 1) INSTALLATIONS WITHIN PAVED AREAS OR SUBJECT TO VEHICULAR LOADING REQUIRE TRAFFIC RATED BOXES. SET TRAFFIC RATED BOXES 1/2" BELOW FINISH GRADE
- 2) METER SUPPLIED BY TDPUD
- 3) THIS DETAIL SHALL NOT BE USED FOR SINGLE-FAMILY RESIDENTIAL SERVICES

TECHNICAL SPECIFICATIONS		 <p>TRUCKEE DONNER Public Utility District</p>	DRAWING #	REVISED
02200			W-52.5	1-8-2019
02565			SCALE	
02597			NO SCALE	
02640			DRAWN	APPROVED
02641		NK	NK	

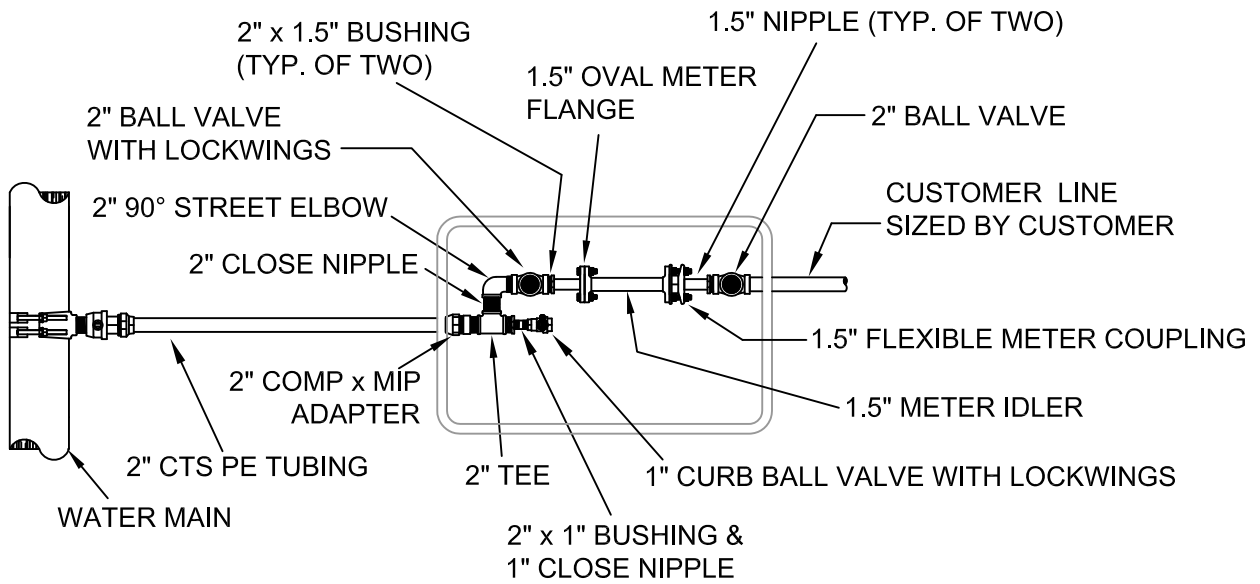

PLAN VIEW

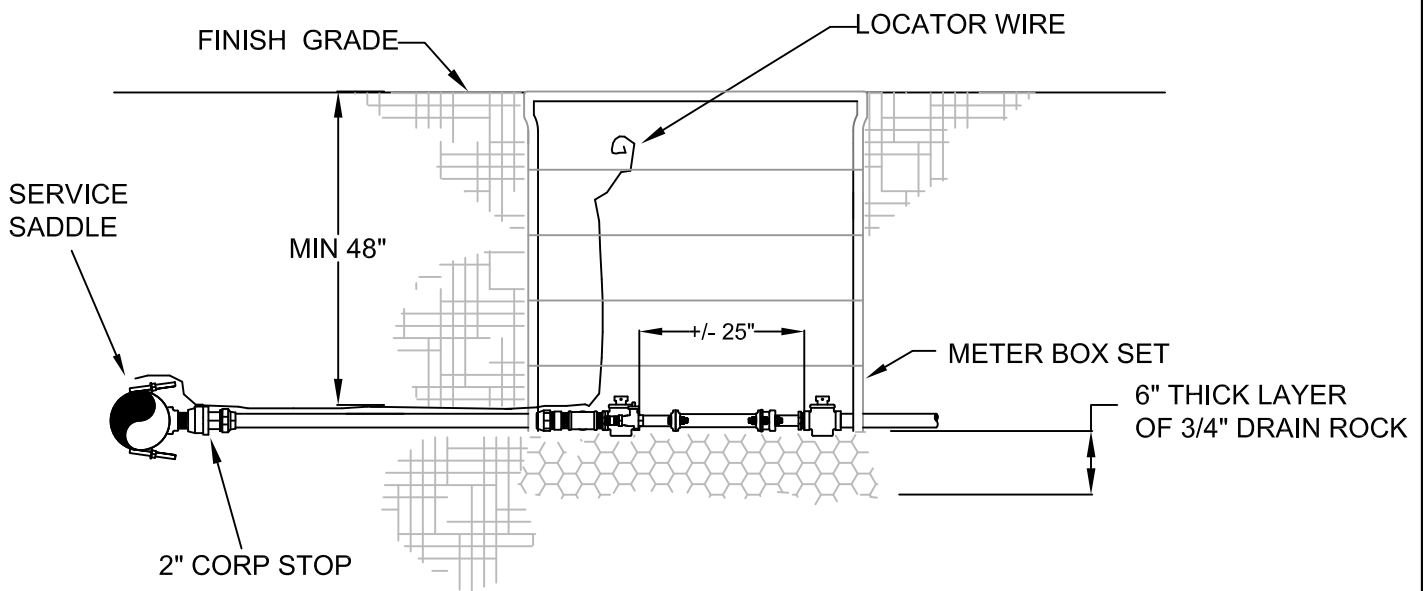

PROFILE VIEW

NOTES:

- 1) INSTALLATIONS WITHIN PAVED AREAS OR SUBJECT TO VEHICULAR LOADING REQUIRE TRAFFIC RATED BOXES. SET TRAFFIC RATED BOXES $\frac{1}{2}$ " BELOW FINISH GRADE.
- 2) METER PROVIDED AND INSTALLED BY T.D.P.U.D.

TECHNICAL SPECIFICATIONS		 TRUCKEE DONNER Public Utility District	DRAWING #	REVISED
02200			W-53.5	1-8-2019
02565			SCALE	
02597			NO SCALE	
02640			DRAWN	APPROVED
02641		NK	NK	

CONSTRUCTION NOTES:

1. INSTALLATIONS WITHIN PAVED AREAS OR SUBJECT TO VEHICULAR LOADING REQUIRE TRAFFIC RATED BOXES. SET TRAFFIC RATED BOXES $\frac{1}{2}$ " BELOW FINISH GRADE.
2. METER PROVIDED AND INSTALLED BY T.D.P.U.D.

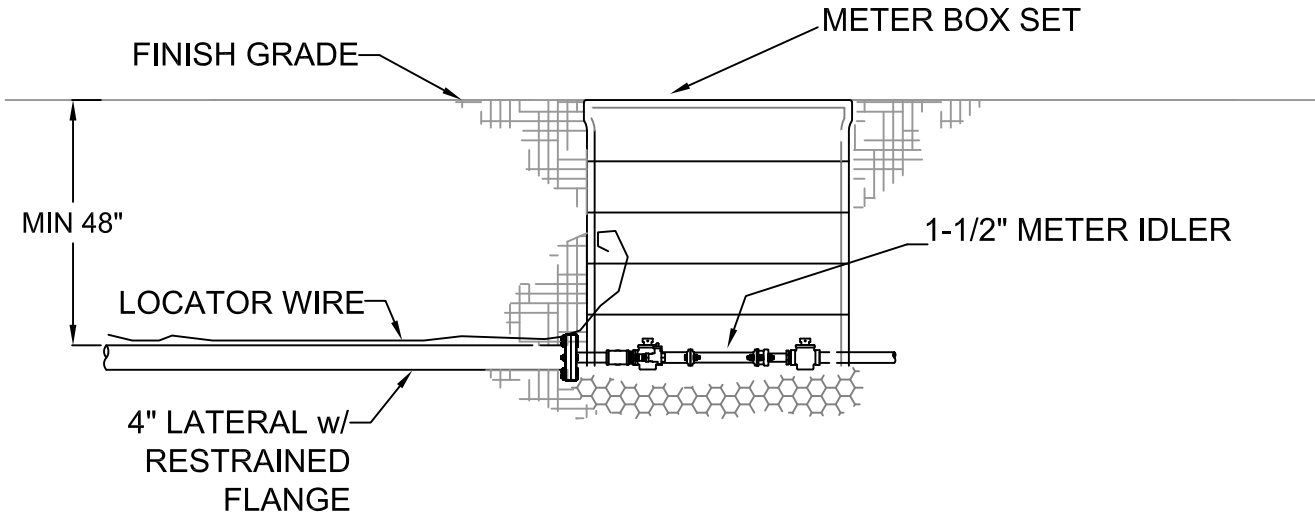

PROFILE VIEW

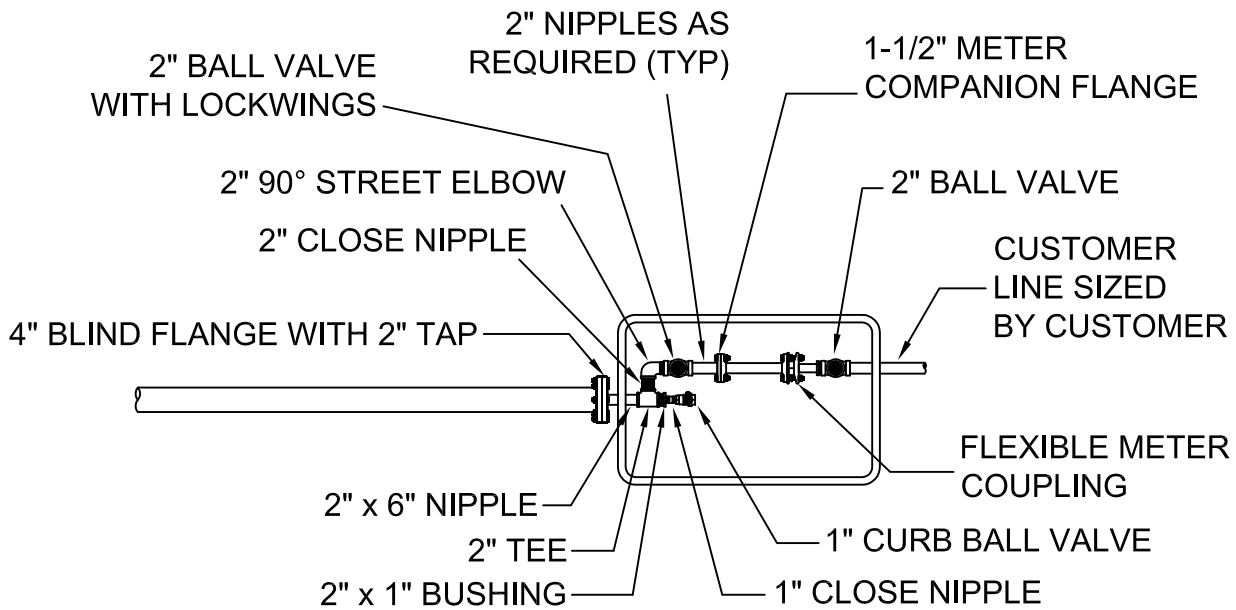

PLAN VIEW

TECHNICAL SPECIFICATIONS		1-1/2" TURBINE METER DETAIL	DRAWING #	REVISED
02200			W-54.4	1-8-2019
02565		 TRUCKEE DONNER Public Utility District	SCALE	
02597			NO SCALE	
02640			DRAWN	APPROVED
02641			MC	NK
02643				

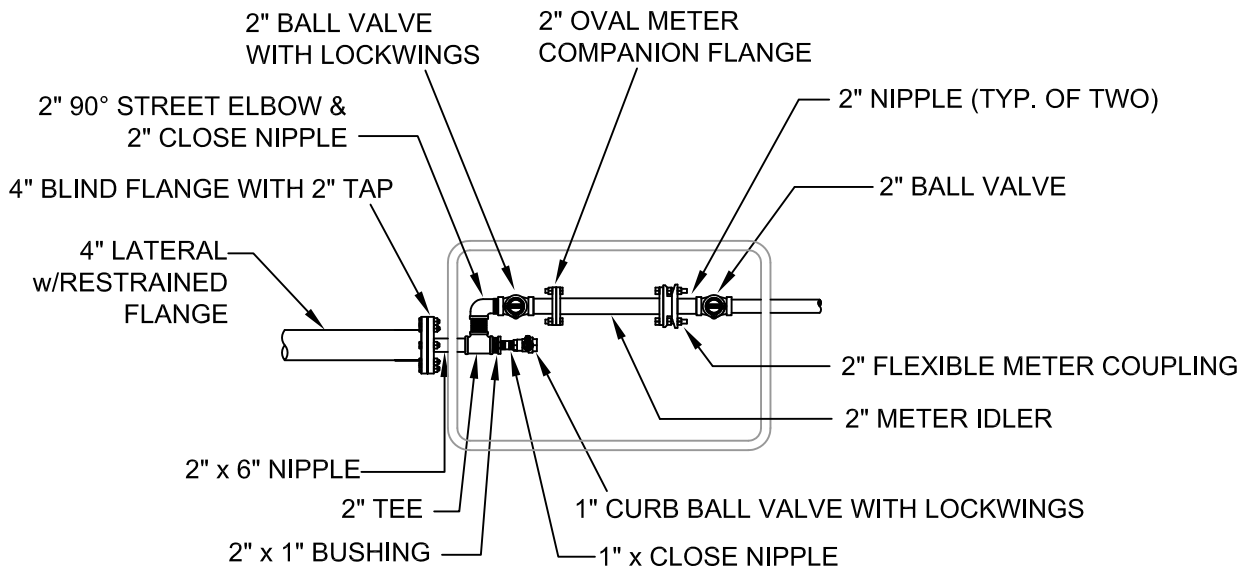

PLAN VIEW

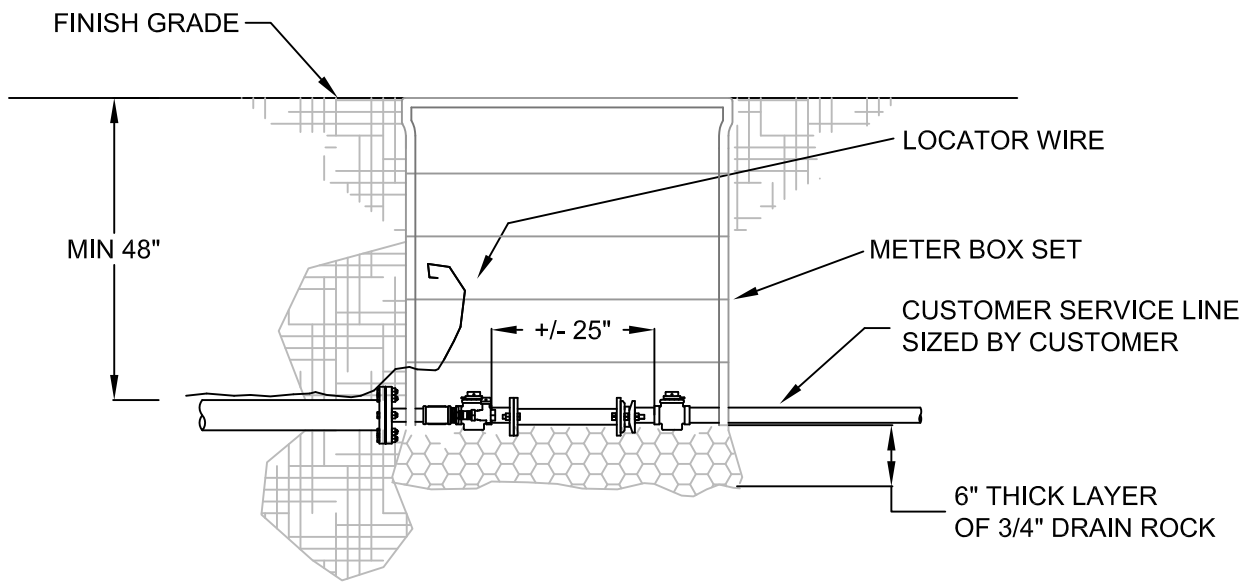

PROFILE VIEW

NOTES:

- 1) INSTALLATIONS WITHIN PAVED AREAS OR SUBJECT TO VEHICULAR LOADING REQUIRE TRAFFIC RATED BOXES. SET TRAFFIC RATED BOXES $\frac{1}{2}$ " BELOW FINISH GRADE.
- 2) METER PROVIDED AND INSTALLED BY T.D.P.U.D.

TECHNICAL SPECIFICATIONS		2" DISC METER DETAIL	DRAWING #	REVISED
02200			W-55.4	1-8-2019
02565		 TRUCKEE DONNER Public Utility District	SCALE	
02597			NO SCALE	
02640			DRAWN	APPROVED
02641			NK	NK

CONSTRUCTION NOTES:

1. INSTALLATIONS WITHIN PAVED AREAS OR SUBJECT TO TRAFFIC LOADING REQUIRE TRAFFIC RATED BOXES. SET TRAFFIC RATED BOXES $\frac{1}{2}$ " BELOW FINISH GRADE.
2. METERS SUPPLIED AND INSTALLED BY TDPUD.

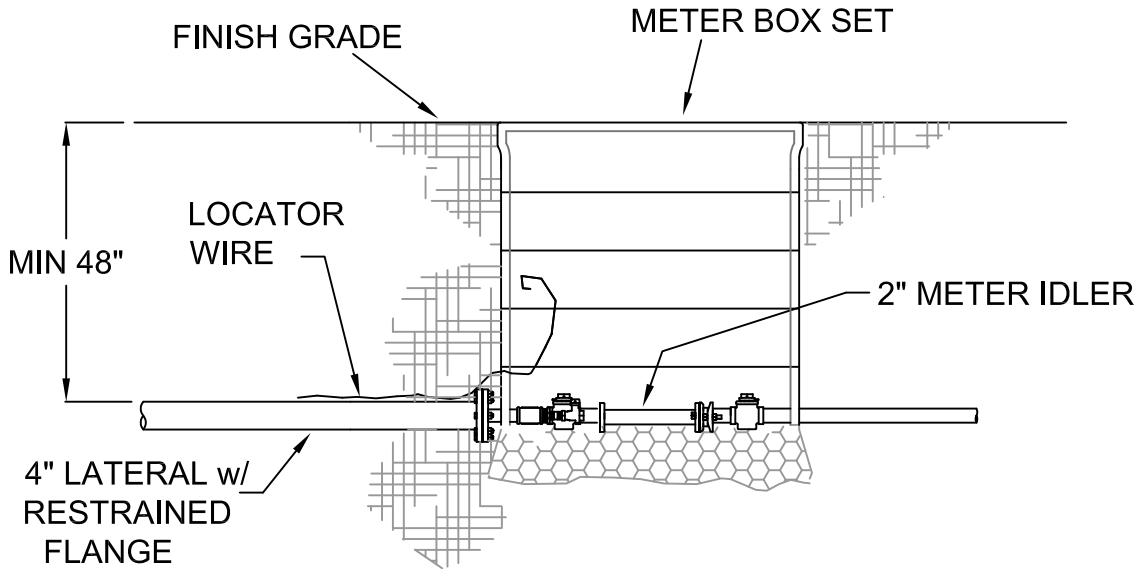

PROFILE VIEW

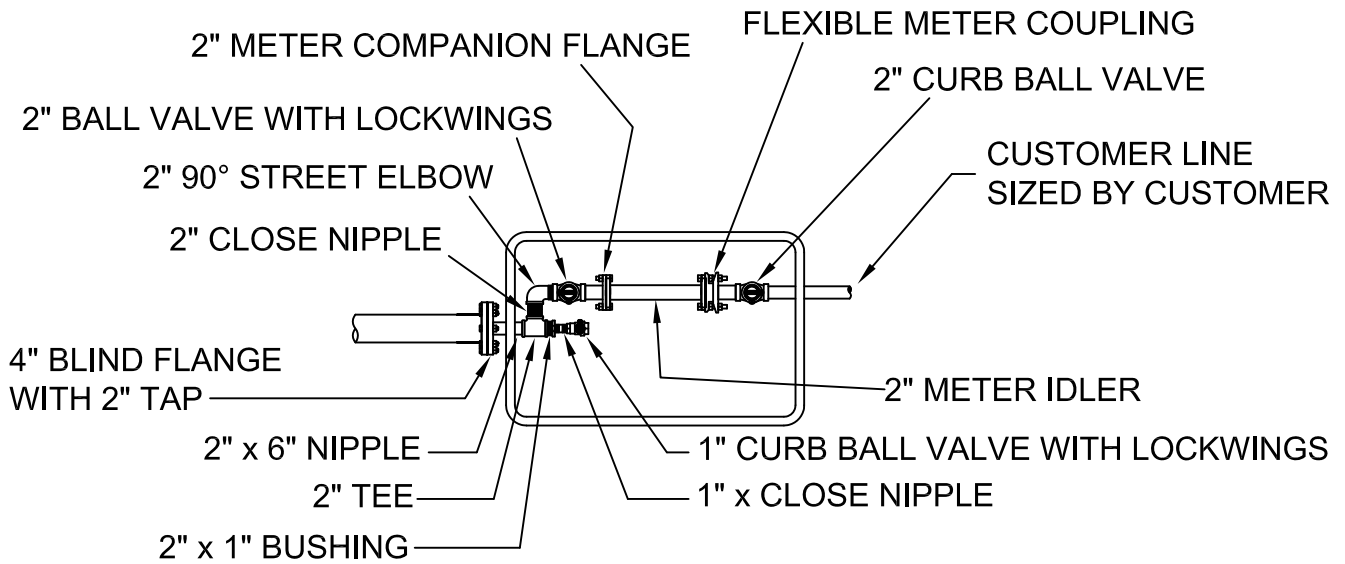

PLAN VIEW

TECHNICAL SPECIFICATIONS		2" TURBINE METER DETAIL	DRAWING #	REVISED
02200			W-56.4	1-8-2019
02565		 TRUCKEE DONNER Public Utility District	SCALE	
02597			NO SCALE	
02640			DRAWN	APPROVED
02641			MC	NK
02643				

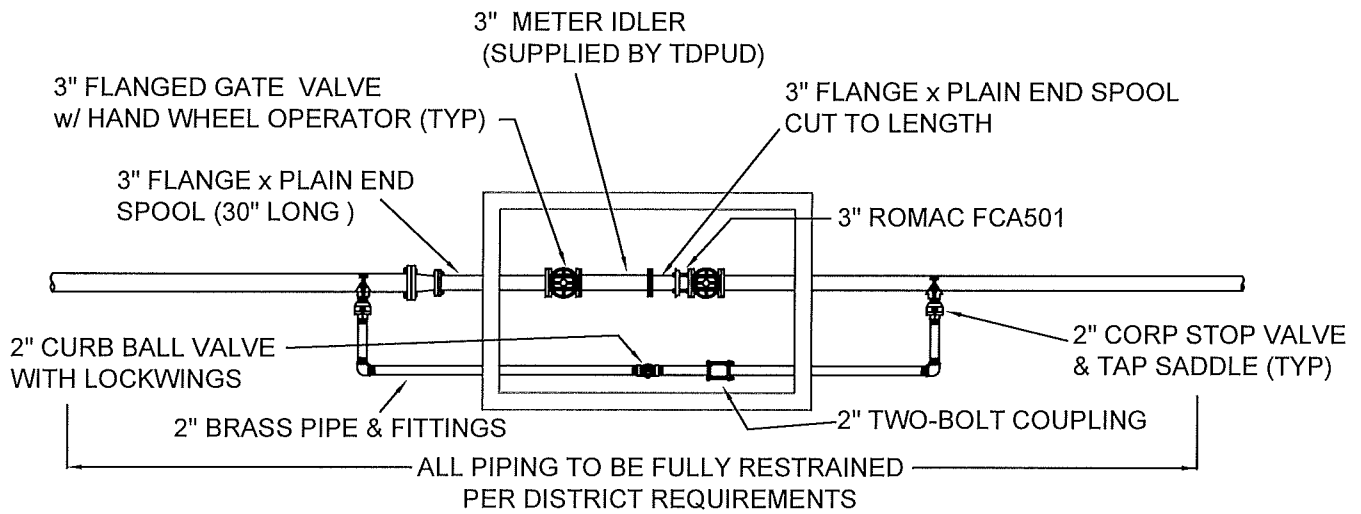
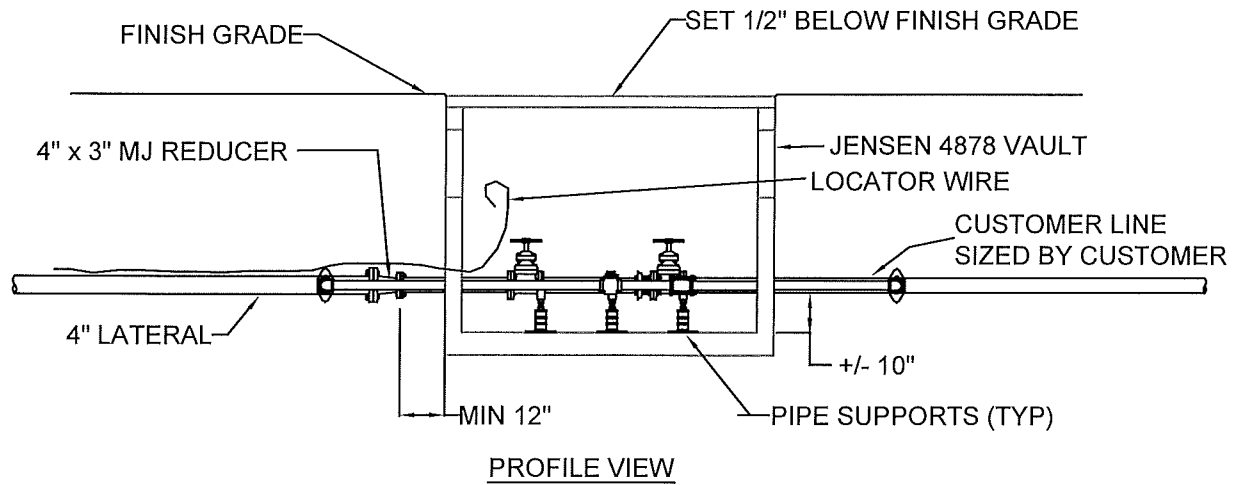

NOTES:

- 1) ALL MATERIALS & CONSTRUCTION PER TDPUD STANDARDS/REQUIREMENTS.
- 2) METER IDLER SUPPLIED BY TDPUD PRIOR TO ASSEMBLY CONSTRUCTION.
- 3) METER SUPPLIED & INSTALLED BY TDPUD.
- 4) ALL PIPING THROUGH VAULT TO MAINTAIN VERTICAL & HORIZONTAL ALIGNMENT.
- 5) ALL 3" PIPING THROUGH VAULT TO BE DUCTILE IRON.
- 6) ANNULAR SPACE BETWEEN PIPE AND VAULT WALL SHALL BE SEALED WITH "LINK-SEAL" MODULAR SEALS OR APPROVED EQUAL.
- 7) INSTALL "METER TRANSMITTER UNIT BOX" PER DETAIL W-63.x

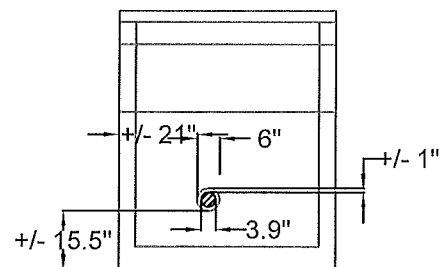

KNOCKOUT DIMENSIONS

TECHNICAL SPECIFICATIONS		3" TURBINE METER DETAIL	DRAWING #	REVISED
02200	15206			W-57.5
02565	15233		SCALE	
02597	W-63.X		NO SCALE	
02640			DRAWN	APPROVED
02641			NK	NK
02643				

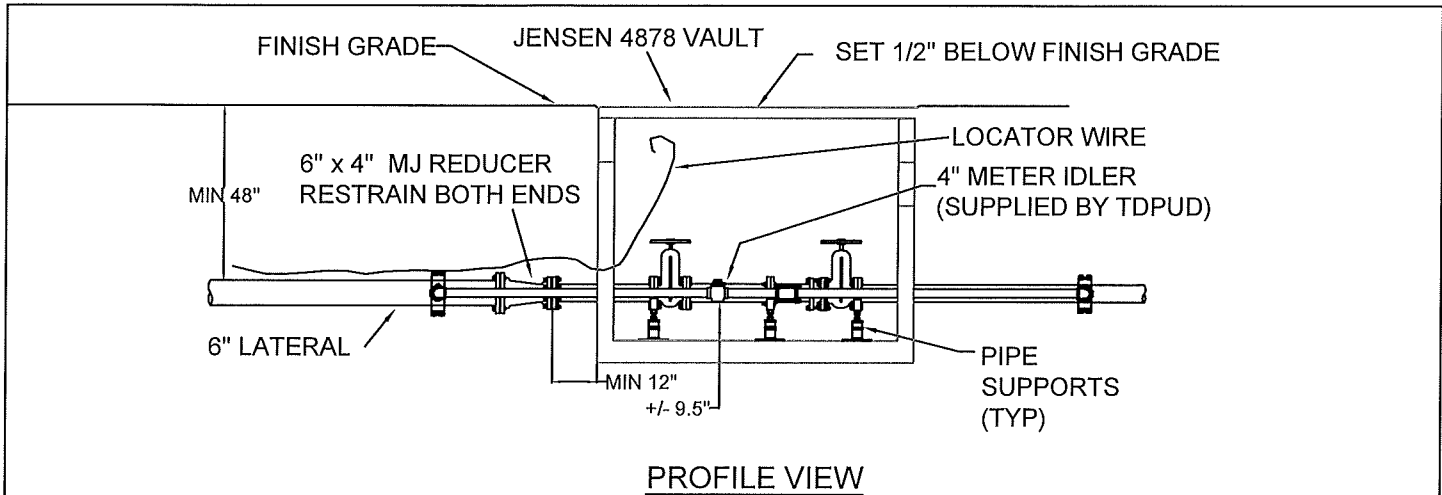

PROFILE VIEW

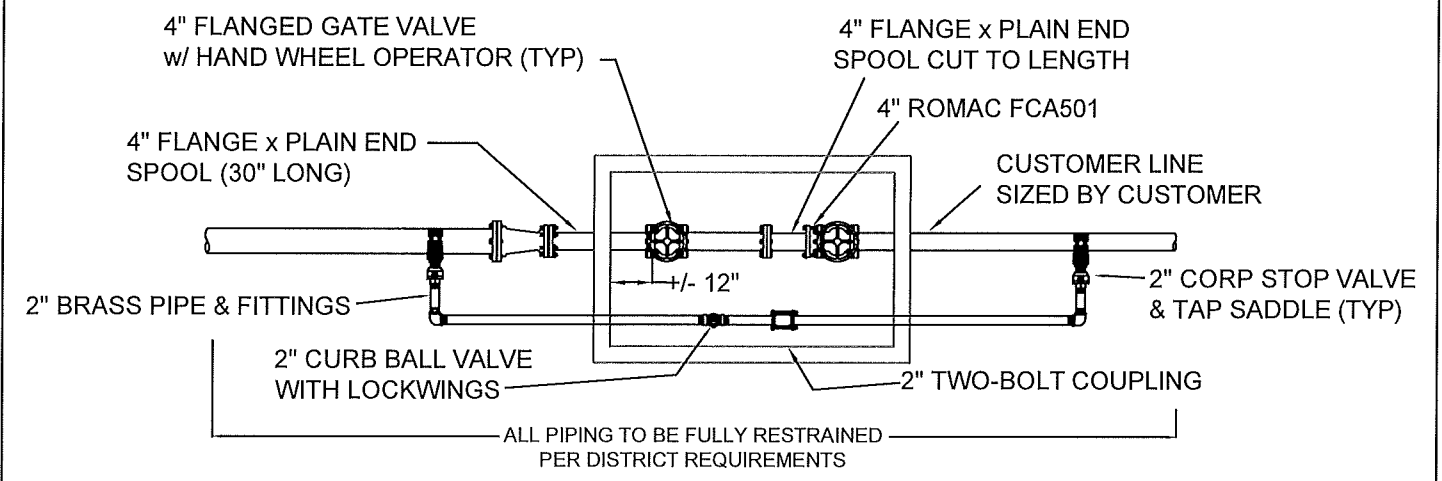

PLAN VIEW

NOTES:

- 1) ALL MATERIALS & CONSTRUCTION PER TDPUD STANDARDS/REQUIREMENTS.
- 2) METER IDLER SUPPLIED BY TDPUD PRIOR TO ASSEMBLY CONSTRUCTION.
- 3) METER SUPPLIED & INSTALLED BY TDPUD.
- 4) ALL PIPING THROUGH VAULT TO MAINTAIN VERTICAL & HORIZONTAL ALIGNMENT.
- 5) ALL 4" PIPING THROUGH VAULT TO BE DUCTILE IRON.
- 6) ANNULAR SPACE BETWEEN PIPE AND VAULT WALL SHALL BE SEALED WITH "LINK-SEAL" MODULAR SEALS OR APPROVED EQUAL.
- 7) INSTALL "METER TRANSMITTER UNIT BOX" PER DETAIL W-63.x

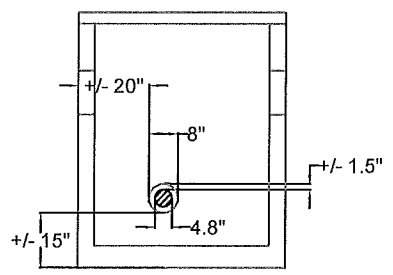

KNOCKOUT DIMENSIONS

TECHNICAL SPECIFICATIONS		4" TURBINE METER DETAIL	DRAWING #	REVISED
02200	15206		 TRUCKEE DONNER Public Utility District	W-58.5
02565	15233	SCALE		
02597	W-63.X	NO SCALE		
02640		DRAWN		APPROVED
02641		NK		NK
02643				

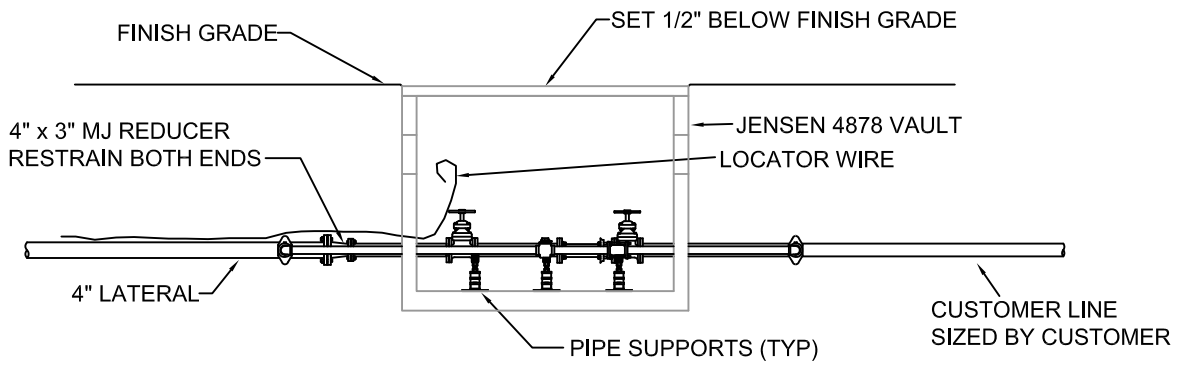

PROFILE VIEW

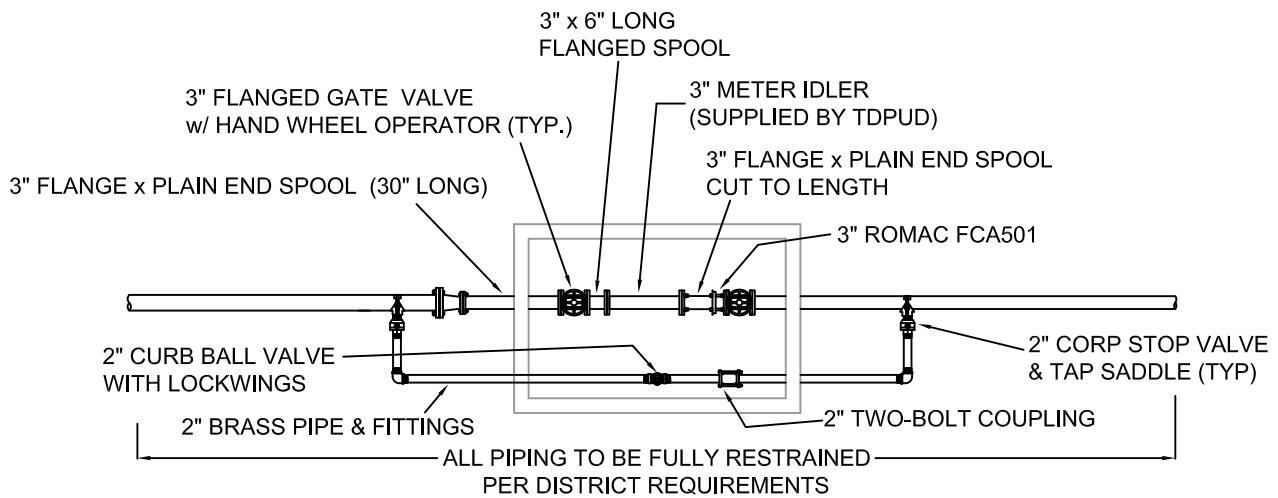

PLAN VIEW

NOTES:

- 1) ALL MATERIALS & CONSTRUCTION PER TDPUD STANDARDS/REQUIREMENTS.
- 2) METER IDLER SUPPLIED BY TDPUD PRIOR TO ASSEMBLY CONSTRUCTION.
- 3) METER SUPPLIED & INSTALLED BY TDPUD.
- 4) ALL PIPING THROUGH VAULT TO MAINTAIN VERTICAL & HORIZONTAL ALIGNMENT.
- 5) ALL 3" PIPING THROUGH VAULT TO BE DUCTILE IRON.
- 6) ANNULAR SPACE BETWEEN PIPE AND VAULT WALL SHALL BE SEALED WITH "LINK-SEAL" MODULAR SEALS OR APPROVED EQUAL.
- 7) INSTALL "METER TRANSMITTER UNIT BOX" PER DETAIL W-63.x

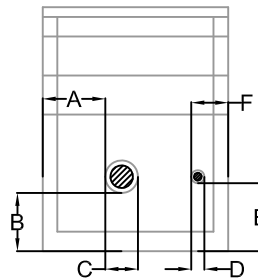

VAULT KNOCKOUTS

A	21"
B	FIELD VERIFY PRIOR TO INSTALLATION
C	6"
D	4"
E	FIELD VERIFY PRIOR TO INSTALLATION
F	12"

KNOCKOUT DIMENSIONS

TECHNICAL SPECIFICATIONS		3" COMPOUND METER DETAIL	DRAWING #	REVISED
02200	15206		 TRUCKEE DONNER Public Utility District	W-60.3
02565	15233	SCALE		
02597	W-63.X	NO SCALE		
02640		DRAWN		APPROVED
02641		NK		NK
02643				

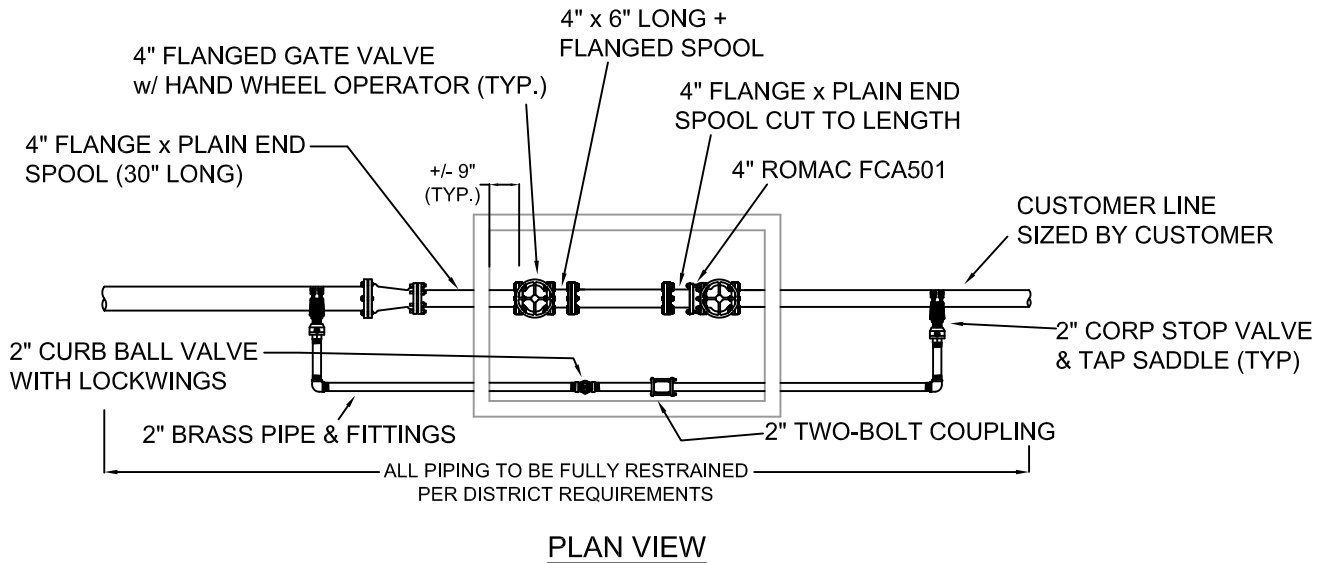
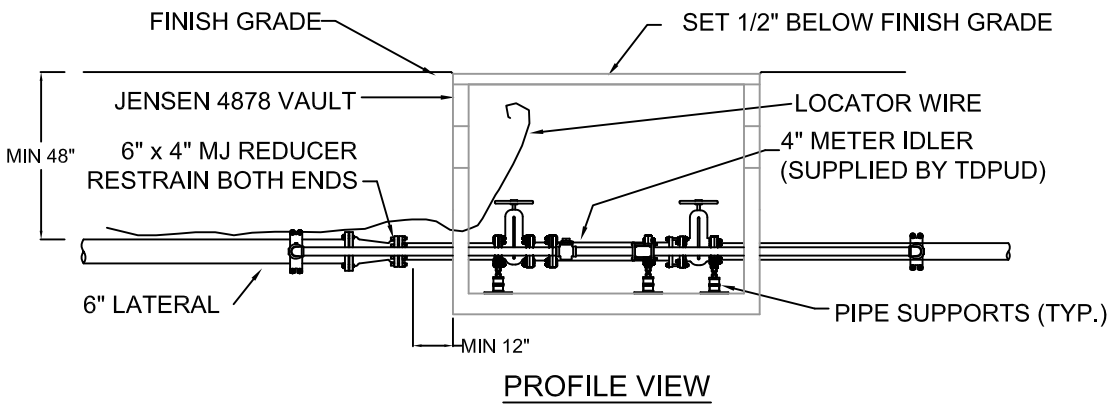

NOTES:

- 1) ALL MATERIALS & CONSTRUCTION PER TDPUD STANDARDS/REQUIREMENTS.
- 2) METER IDLER SUPPLIED BY TDPUD PRIOR TO ASSEMBLY CONSTRUCTION.
- 3) METER SUPPLIED & INSTALLED BY TDPUD.
- 4) ALL PIPING THROUGH VAULT TO MAINTAIN VERTICAL & HORIZONTAL ALIGNMENT.
- 5) ALL 4" PIPING THROUGH VAULT TO BE DUCTILE IRON.
- 6) ANNULAR SPACE BETWEEN PIPE AND VAULT WALL SHALL BE SEALED WITH "LINK-SEAL" MODULAR SEALS OR APPROVED EQUAL.
- 7) INSTALL "METER TRANSMITTER UNIT BOX" PER DETAIL W-63.x

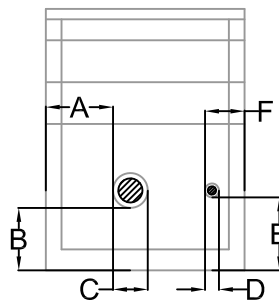

VAULT KNOCKOUTS

A	20"
B	FIELD VERIFY PRIOR TO INSTALLATION
C	8"
D	4"
E	FIELD VERIFY PRIOR TO INSTALLATION
F	12"

KNOCKOUT DIMENSIONS

TECHNICAL SPECIFICATIONS		4" COMPOUND METER DETAIL	DRAWING #	REVISED
02200	15206		W-61.3	1-8-2019
02565	15233	 TRUCKEE DONNER Public Utility District	SCALE	
02597	W-63.X		NO SCALE	
02640			DRAWN	APPROVED
02641			NK	NK
02643				

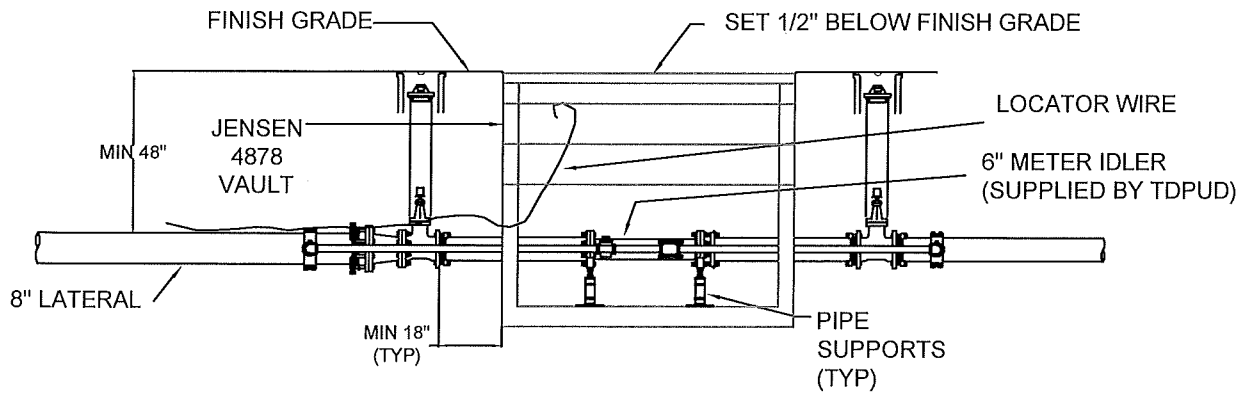

PROFILE VIEW

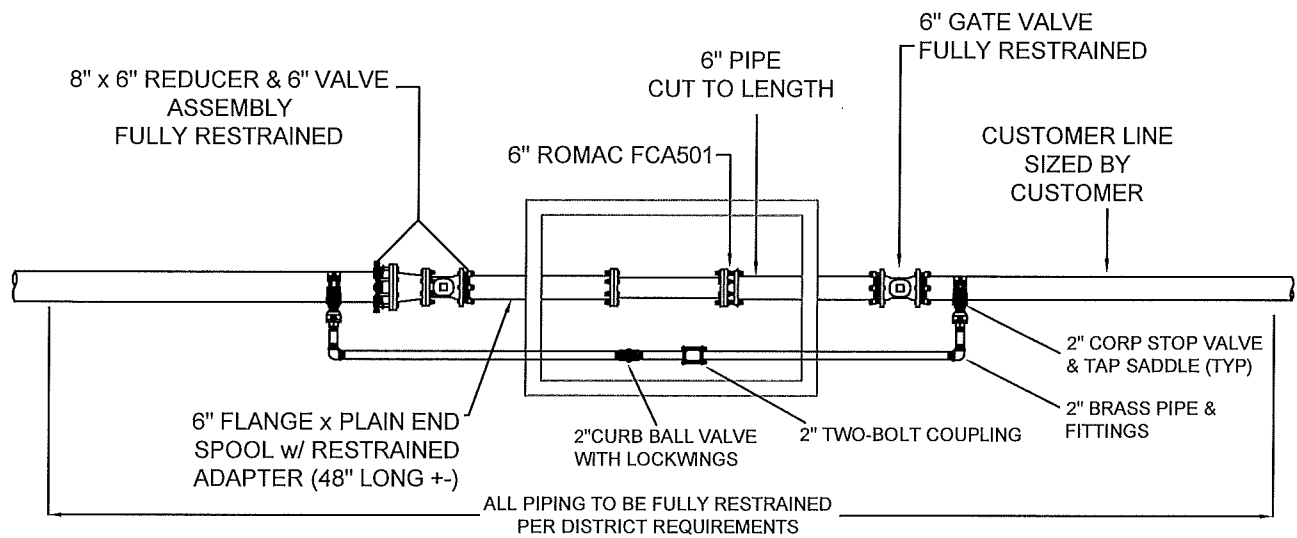

PLAN VIEW

NOTES:

- 1) ALL MATERIALS & CONSTRUCTION PER TDPUD STANDARDS/REQUIREMENTS.
- 2) METER IDLER SUPPLIED BY TDPUD PRIOR TO ASSEMBLY CONSTRUCTION.
- 3) METER SUPPLIED & INSTALLED BY TDPUD.
- 4) ALL PIPING THROUGH VAULT TO MAINTAIN VERTICAL & HORIZONTAL ALIGNMENT.
- 5) ALL 6" PIPING THROUGH VAULT TO BE DUCTILE IRON.
- 6) ANNULAR SPACE BETWEEN PIPE AND VAULT WALL SHALL BE SEALED WITH "LINK-SEAL" MODULAR SEALS OR APPROVED EQUAL.
- 7) INSTALL "METER TRANSMITTER UNIT BOX" PER DETAIL W-63.x

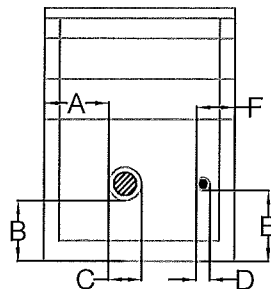

VAULT KNOCKOUTS

A	19.25"
B	FIELD VERIFY PRIOR TO INSTALLATION
C	10"
D	4"
E	FIELD VERIFY PRIOR TO INSTALLATION
F	12"

KNOCKOUT DIMENSIONS

TECHNICAL SPECIFICATIONS		6" COMPOUND METER DETAIL	DRAWING #	REVISED
02200	15206		 TRUCKEE DONNER Public Utility District	W-62.2
02565	15233	SCALE		
02597	W-63.X	NO SCALE		
02640		DRAWN		APPROVED
02641		NK		NK
02643				

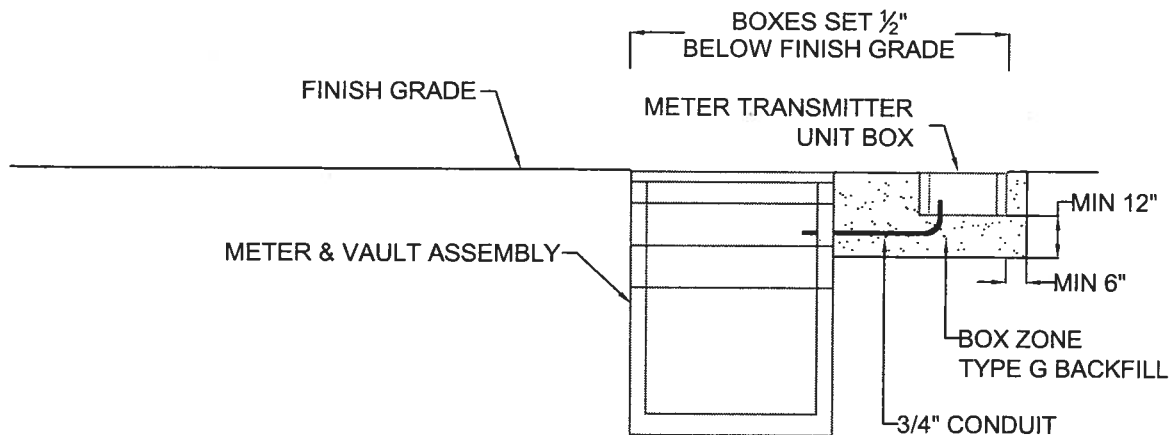

PROFILE VIEW

CONSTRUCTION NOTES:

1. ALL MATERIALS & CONSTRUCTION PER TDPUD STANDARDS/REQUIREMENTS.
2. 3/4" SCH 40 ELECTRICAL CONDUIT.
3. ANNULAR SPACE BETWEEN CONDUIT AND VAULT TO BE GROUTED.
4. REFER TO SPECIFICATIONS AND DETAILS FOR VAULT INSTALLATIONS.

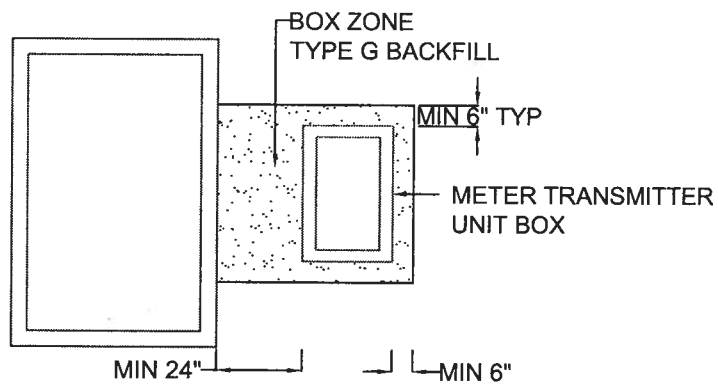

PLAN VIEW

TECHNICAL SPECIFICATIONS		METER TRANSMITTER UNIT BOX DETAIL	DRAWING #	REVISED
02200			W-63.1	1-4-10
02640			SCALE	
		 TRUCKEE DONNER Public Utility District	NO SCALE	
			DRAWN	APPROVED
			MC	NK

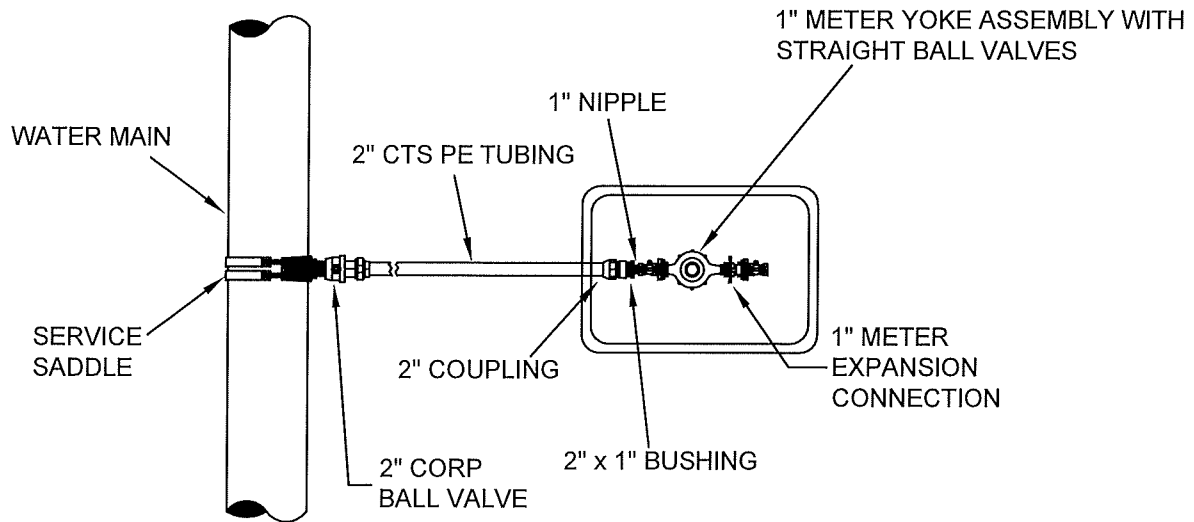

PLAN VIEW

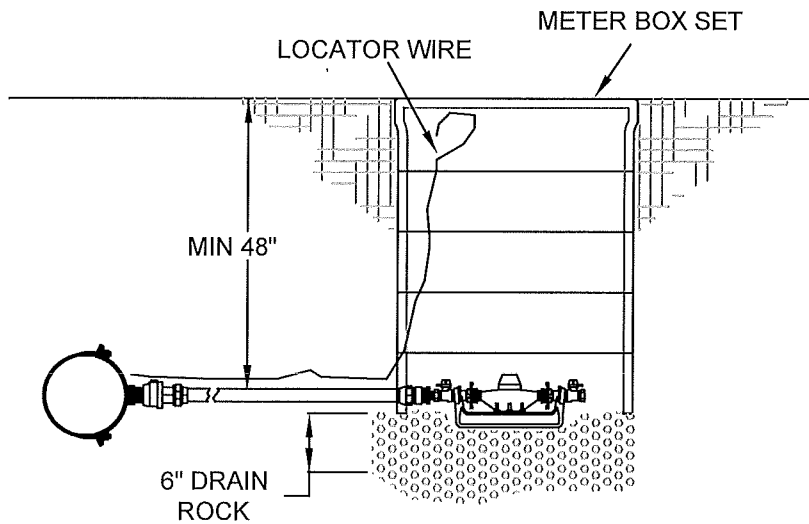

PROFILE VIEW

NOTE: INSTALLATIONS WITHIN PAVED AREAS OR SUBJECT TO TRAFFIC LOADING REQUIRE TRAFFIC RATED BOXES. SET TRAFFIC RATED BOXES 1/2" BELOW FINISH GRADE.

TECHNICAL SPECIFICATIONS		SINGLE SERVICE DETAIL SINGLE FAMILY RESIDENTIAL CONNECTION WITH FIRE SPRINKLERS  TRUCKEE DONNER Public Utility District	DRAWING #	REVISED
02200			W-70.3	1-9-2017
02641			SCALE	
02642			NO SCALE	
02643			DRAWN	APPROVED
		NK	NK	

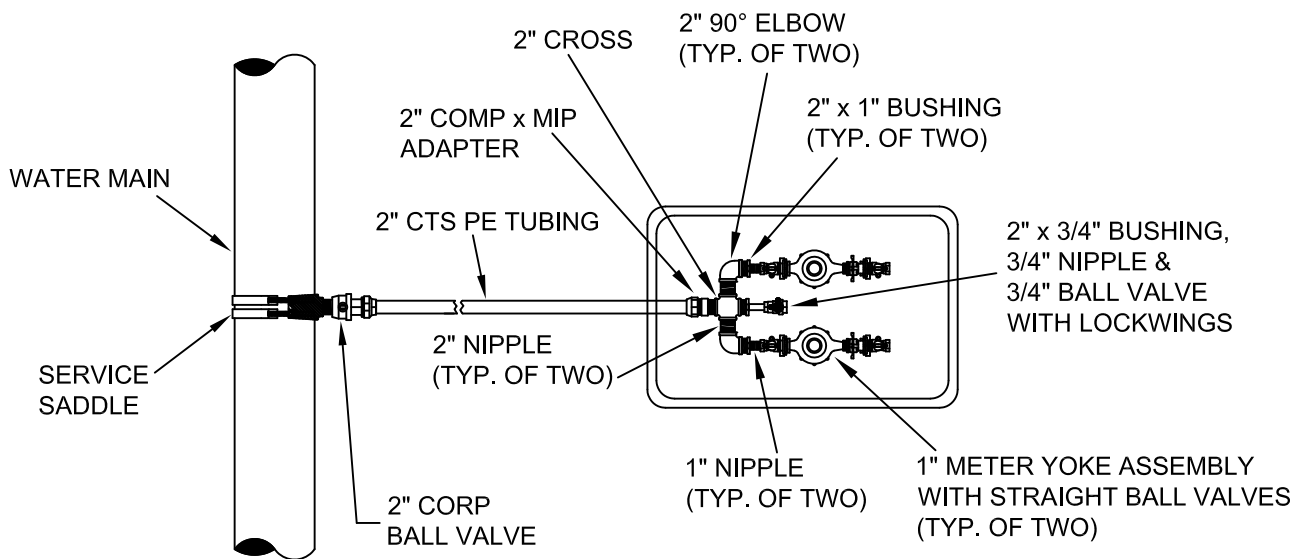

PLAN VIEW

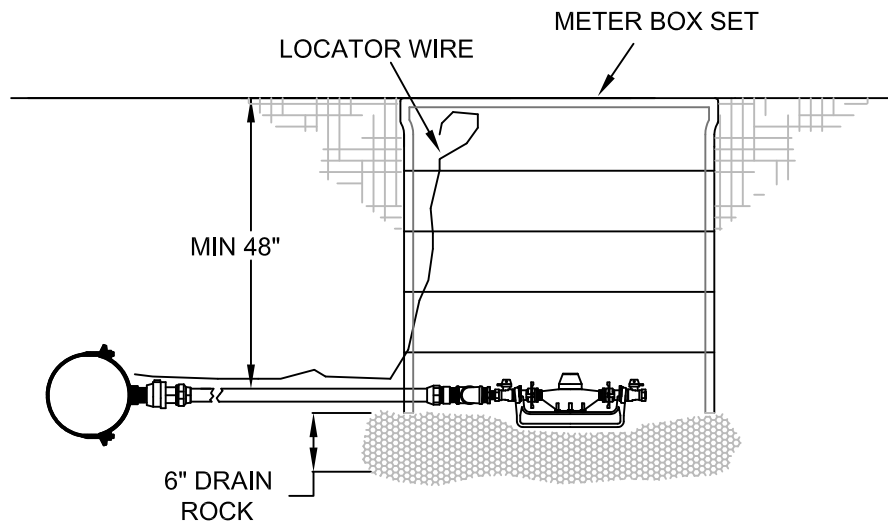

PROFILE VIEW

NOTE: INSTALLATIONS WITHIN PAVED AREAS OR SUBJECT TO TRAFFIC LOADING REQUIRE TRAFFIC RATED BOXES. SET TRAFFIC RATED BOXES 1/2" BELOW FINISH GRADE.

TECHNICAL SPECIFICATIONS		<p style="text-align: center;">DOUBLE SERVICE DETAIL SINGLE FAMILY RESIDENTIAL CONNECTIONS WITH FIRE SPRINKLERS</p>  <p style="text-align: center;">TRUCKEE DONNER Public Utility District</p>	DRAWING # W-71.4	REVISED 1-8-2019
02200			SCALE	
02641			NO SCALE	
02642			DRAWN	APPROVED
02643			NK	NK

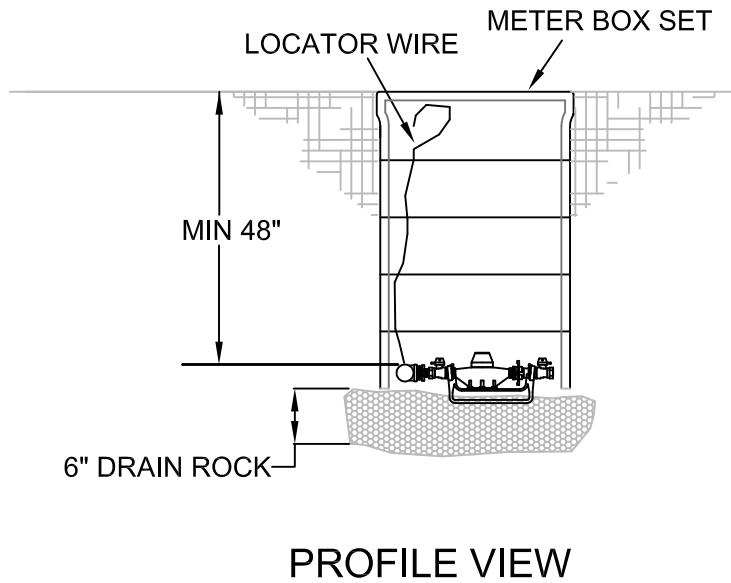
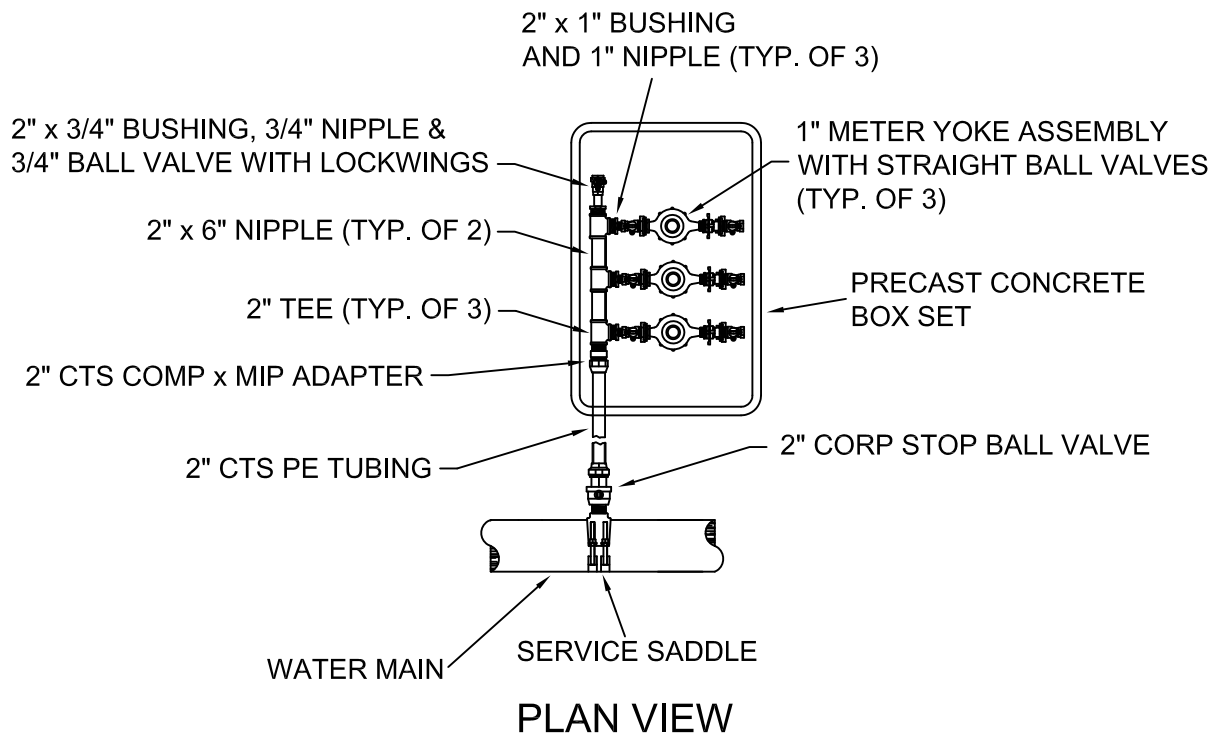

NOTE: INSTALLATIONS WITHIN PAVED AREAS OR SUBJECT TO TRAFFIC LOADING REQUIRE TRAFFIC RATED BOXES. SET TRAFFIC RATED BOXES 1/2" BELOW FINISH GRADE.

TECHNICAL SPECIFICATIONS		 <p>TRUCKEE DONNER Public Utility District</p>	DRAWING # W-72.2	REVISED 1-8-2019
02200			SCALE	
02641			NO SCALE	
02642			DRAWN	APPROVED
02643			NDK	NDK

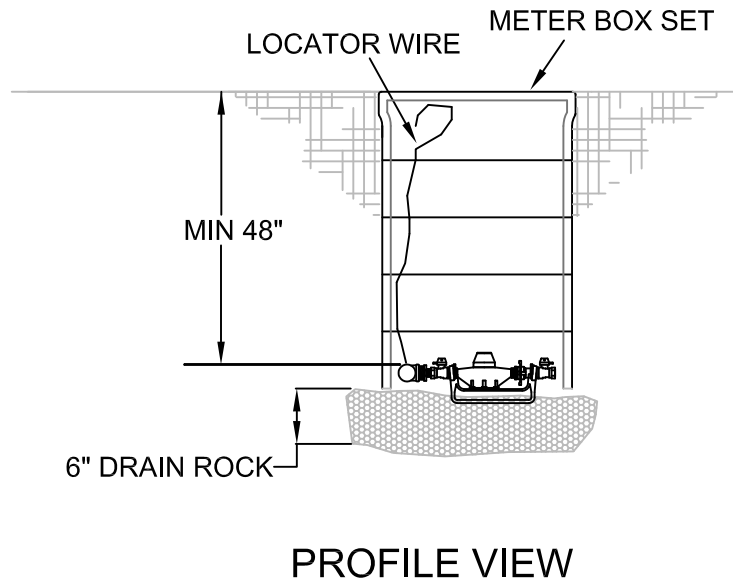
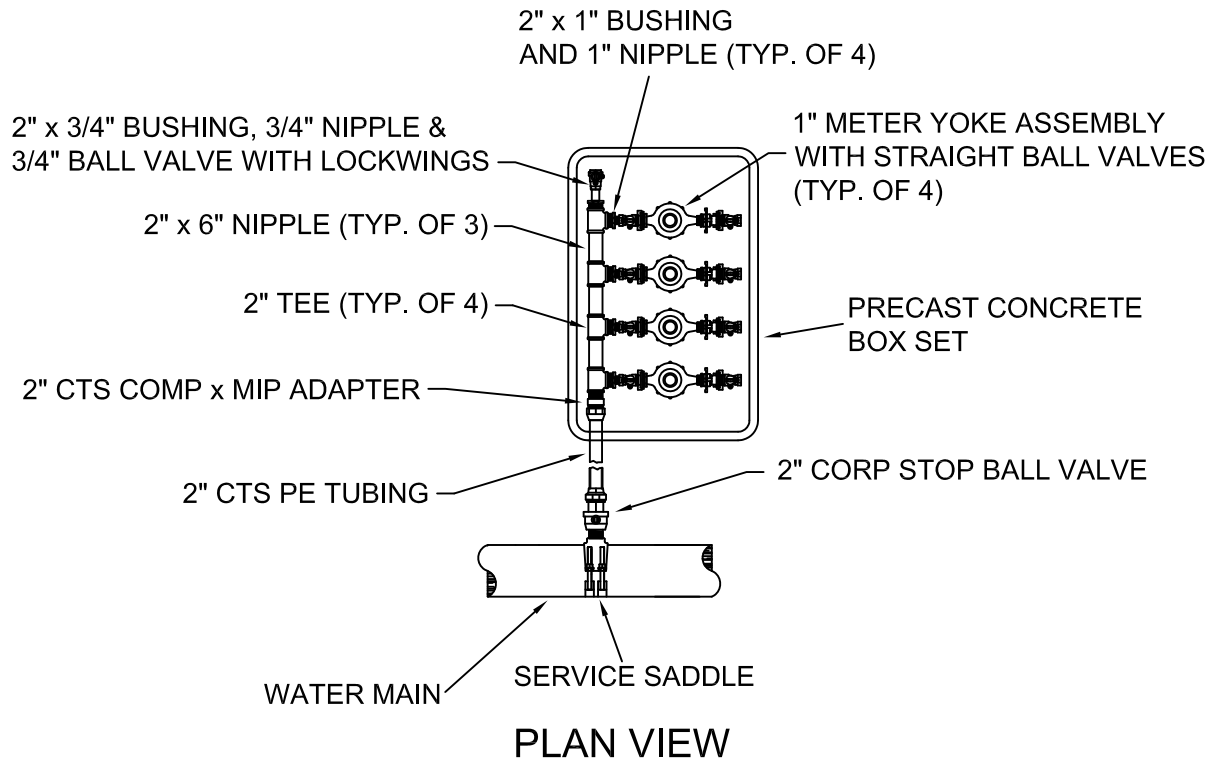

NOTE: INSTALLATIONS WITHIN PAVED AREAS OR SUBJECT TO TRAFFIC LOADING REQUIRE TRAFFIC RATED BOXES. SET TRAFFIC RATED BOXES 1/2" BELOW FINISH GRADE.

TECHNICAL SPECIFICATIONS		FOUR METER SERVICE DETAIL FOR SFR CONNECTIONS WITH FIRE SPRINKLERS	DRAWING #	REVISED
02200			 TRUCKEE DONNER Public Utility District	W-73.2
02641		SCALE		
02642		NO SCALE		
02643		DRAWN		APPROVED
			NDK	NDK